

# **Uniform Shipping Laws Code 2008**

**Section 5M: Construction – Timber  
(CTH, NSW, NT, QLD, SA, TAS, VIC & WA)**

This is not the official version of the Uniform Shipping Laws Code.  
The official version is that last published by the Australian Government Publishing Service, Canberra, copies of which can be obtained from the National Marine Safety Committee.

**SUB-SECTION M  
TIMBER**

This Sub-section is divided into Parts as follows:

Part 1—Application and General

Part 2—Scantlings for Round Bilge Vessels

Part 3—Scantlings for Hard Chine Vessels

Part 4—Scantlings for Hard Chine Plywood Hulls Constructed on a System of Longitudinal Frames Supported by Web Frames

Part 5—Scantlings for Vessels of Sawn Frame Construction

Part 6—Tables

Part 7—Sketches

**PART 1—APPLICATION AND GENERAL**

**CONTENTS**

<i>Clause</i>	<i>Title</i>
M.1	Preliminary
M.2	Application
M.3	General
M.4	Fastenings

---

**PART 1—APPLICATION AND GENERAL**

**M.1 Preliminary**

M.1.1 This Sub-section forms part of the Construction Section and shall be read in conjunction with its other Sub-sections.

M.1.2 The Construction Section shall be read in conjunction with the Introduction, Definitions and General Requirements Section.

**M.2 Application**

This Sub-section is to apply to timber vessels of less than 35 metres in length. Vessels of 35 metres in length and over will be specially considered by the Authority.

**M.3 General**

**M.3.1 Materials**

Subject to clause M.57, these requirements apply to vessels constructed of timber and framed with bent or web frames.

- (a) All materials used shall be of best quality. The timber shall be rot free, adequately seasoned and free from sap, shakes, objectionable knots and other defects, suitable for the purpose intended, and conforming with the requirements of Australian Standard AS1738-1975, Timber for Marine Craft.
- (b) All metals used in the construction shall be suitable for a marine environment, or in the case of mild steel protected against corrosion, and conform to relevant Australian or British Standard Specifications. Care should be exercised in the selection of metals used in order to obviate the effects of electro-chemical corrosion.
- (c) Marine plywoods used shall conform to Australian Standard AS2272-1979, Plywood for Marine Craft. Attention is to be given, during the installation of plywood, to the

edges and any holes made in the face of the sheet. The entry of moisture is facilitated at these points and its entry can lead to a rapid deterioration of this material without any apparent evidence of such breakdown being present on the surface veneers of the ply.

- (d) Glues to be used in the construction and lamination of structural members are to be gap-filling resorcinol or phenolic type such as those complying with BS 1204, Synthetic Resin Adhesives (Phenolic and Aminoplastic) for Wood, epoxy resins or other equivalent adhesive having similar durability and which can give a Type WBP bond.

Modified urea-formaldehydes may be used in those parts of the internal structure which are not subject to continuously wet conditions and are well ventilated. Such parts include internal deckhouse members and internal structural assemblies which are well above the bilges. Glues are to be mixed and applied in accordance with the manufacturers' instructions and with due regard to the shop temperature and humidity requirements.

The manufacturers' recommendations in regard to glueing different species of timber should be followed, especially those regarding the degreasing of oily or resinous timbers and also the effect of timber preservatives on the glues.

- (e) The scantling dimensions give in the tables are for stock milled sizes with a minimum of loss for dressing. Sizes, except where specially noted, are for Australian hardwoods of 960kg/m<sup>3</sup> density at 12% moisture content. Where the actual density of the timber used is less than 800kg/m<sup>3</sup> density at 12% moisture content the tabulated scantlings

are to be increased by the ratio  $\frac{960}{W}$  where

W = the actual density in kilograms/cubic metre at 12% moisture content of the timber being used. The densities of timbers at 12% moisture content shall be obtained from the 'Australian Standard AS 1738-1975, Timber for Marine Craft'. Where a dimension lies between any two consecutive numerals in the tables then the scantling may be determined by the next higher dimensions or by direct interpolation.

#### M.3.2 Alternate Construction Methods

The scantlings of vessels constructed on other than the framing systems described herein shall be determined on the basis of the midship section modulus being considered equivalent to the midship section modulus of a vessel of similar dimensions obtained from the application of this Sub-section, and also that the stresses in the individual members of the vessel are acceptable to the Authority. Data to indicate the midship section modulus obtained and the stresses involved may be required to be submitted for approval.

### M.4 Fastenings

#### M4.1 General

M.4.1.1 Fastenings may be of copper, gun metal, silicon bronze, mild steel, stainless steel or monel metal. They shall be in accordance with Table M.26.

M.4.1.2 All fastenings of ferrous metal shall be suitably protected.

M.4.1.3 Dumps, where used in lieu of a bolt, shall have the same cross sectional area.

M.4.1.4 Fastenings may be increased above the sizes shown in the table, but any increase shall be such that the fastening does not unduly weaken the member.

M.4.1.5 All fastenings of stainless steel shall be of type 316 material.

M.4.1.6 Iron or steel fastenings shall not be used in the underwater portion of any vessel sheathed with copper or other non-ferrous material.

M.4.1.7 Through fastenings, other than nails, shall be either rivetted on rings or washers of the same material, or fitted with screw nuts. The material for the rings, washers or nuts shall be compatible with the through fastenings used.

#### M.4.2 Hog to Keel

M.4.2.1 The hog to keel fastenings between floors in vessels less than 15 metres length may be dump fastenings.

4      *Section 5 Sub-section M*

M.4.2.2 In vessels of 15 metres length and over these fastenings shall be through fastenings.

M.4.2.3 There shall be at least one fastening between floors for every 0.1m<sup>2</sup> of faying surface between keel and hog.

M.4.3 Floors

M.4.3.1 Floors shall be through bolted to the keel and hog, and where practicable through the extremities of the arms to the stringer and planking.

M.4.4 Clamps and Stringers

M.4.4.1 Clamps and stringers shall be through fastened at every alternate frame.

M.4.5 Beam Shelf

M.4.5.1 The beam shelf shall be through fastened to the sheer clamp. The maximum spacing of such fastenings shall not exceed twice the frame spacing.

M.4.6 Planking

M.4.6.1 The fastening dimensions for hull planking shall be determined from Table M.26.

M.4.6.2 Planking fastenings to bent frames may be either through nails, screw bolts or wood screws. Through nails shall be either rivetted on roves, or clenched and through fastenings shall be used where frames are laminated and not glued.

M.4.6.3 Clenched nails shall not be used where ever the single moulding of a laminated framing member is less than 15 mm.

M.4.6.4 Plank fastenings into the hog, floors, bulkhead grounds, transom and hood ends shall be copper nails, screws or dumps.

M.4.6.5 The planking hood ends shall be secured with a double row of copper nails, screws or dumps.

M.4.6.6 Plank fastenings into the forward and aft deadwoods and the horn timbers shall be double reeled.

M.4.6.7 All butt straps in the hull planking shall be through fastened with nails, rivetted on roves or clenched, bolted or screwed.

## PART 2—SCANTLINGS FOR ROUND BILGE VESSELS

## CONTENTS

<i>Clause</i>	<i>Title</i>
M.5	Keel and hog or keelson
M.6	Stem
M.7	Apron and forward deadwood
M.8	Sternpost, aft deadwood, shaft log
M.9	Horn timber assembly
M.10	Transom
M.11	Bent or laminated frames
M.12	Web frames
M.13	Floors
M.14	Floors in web framed vessels
M.15	Longitudinal members
M.16	Hull planking
M.17	Decks
M.18	Watertight bulkheads
M.19	Pillars or stanchions
M.20	Engine seatings
M.21	Deckhouses

## PART 2—SCANTLINGS FOR ROUND BILGE VESSELS

## M.5 Keel and Hog or Keelson

M.5.1 (a) The keel shall be sided and moulded as indicated in Table M1. The siding and moulding shown therein may be varied in accordance with the notes to the table.

(b) The minimum hog siding and moulding shall be as shown in Table M1 but may be varied in accordance with the notes to the table.

(c) Where a keelson used in lieu of a hog is associated with a rabbetted keel, the keelson shall have a sectional area and be sided and moulded in accordance with Table M1 and associated notes.

M.5.2 The keel and hog or keelson in vessels less than 10 metres in length shall be in one length.

M.5.3 For vessels 10 metres in length and over where the keel, hog or keelson is not in one length it shall be efficiently scarphed.

Any such proposals shall be clearly indicated on the plans submitted.

M.5.4 The keel and hog or keelson may be scarphed at one third of their respective lengths with at least 10 times the frame spacing shown in Table M6 between the extremities of the scarphs in the keel and hog. Keel and hog or keelson scarphs should be avoided in way of a machinery space.

M.5.5 Keel and hog or keelson scarphs shall be not less in length than six times the moulding of the keel and hog or keelson respectively and have nibs of the following depths:

0.25 times depth of scarph for a moulding up to 200 mm in depth.

0.125 times depth of scarph + 25 mm for a moulding exceeding 200 mm in depth.

M.5.6 Stopwaters shall be fitted to all centreline construction joints where they intercept the rabbet line.

M.5.7 A rabbetted keel, viz. where the keel and hog are made out of one piece of timber or are of laminated construction, may be reduced in cross sectional area by up to 15 per cent of the total combined areas for the keel and hog obtained from the addition of the sectional areas shown in Table M1.

6 Section 5 Sub-section M

**M.6 Stem**

M.6.1 Stem scantlings shall be determined from Table M.2.

M.6.2 The moulding of the stem at the heel may be greater than that of the keel to permit the butting of the docking keel against the scarp end.

M.6.3 The scarp of the stem to the keel shall not be less than 2.5 times the keel moulding in length.

M.6.4 The face of the stem may be reduced in siding below the deckline to conform to a suitable stem band.

**M.7 Apron and Forward Deadwood**

M.7.1 The apron and forward deadwood shall be sided and moulded to permit a double row of fastenings in the planking hood ends.

M.7.2 The outer rabbet line is to be such as to permit a faying surface of twice the planking thickness.

M.7.3 The forward deadwood at the hog position shall be sided not less than the hog.

M.7.4 The forward deadwood knee shall have the same siding as the stem while the moulding in the throat should be not less than 1.5 times the siding.

**M.8 Stern Post, Aft Deadwood, Shaft Log**

M.8.1 The stern or propeller post shall have a minimum siding equal to that of the keel and be in one piece throughout its length. The sternpost is to be connected to the keel by a mortice and tenon joint and also by a dovetail plate or other equivalent connection on both sides in addition to the fastenings (Refer to M.8.3). Scantlings are shown in Table M.3.

M.8.2 The inner posts, deadwoods, and/or shaft logs shall be substantially moulded to permit a double row of fastenings in the hood ends, coupled with a minimum faying surface of 3 times the planking thickness.

M.8.3 The thickness of timber on each side of the shaft tube shall not be less than 0.25 times the keel siding. Where the diameter of the shaft tube is such that there is less than this siding the timber scantling shall be increased to the required dimension in this area.

M.8.4 Inner posts, deadwoods and/or shaft logs may run either horizontally or vertically.

**M.9 Horn Timber Assembly**

M.9.1 The horn timber assembly sectional areas are shown in Table M.4.

M.9.2 The horn timber may be cut from solid timber and locked in with the stern post by a large tenon and mortice. Where the horn timber is cut from solid timber the sectional areas shown in Table M.4 may be reduced by up to 15 per cent.

M.9.3 The horn timber fashion piece may be gradually reduced towards its after end where its sectional area is not then to be less than 0.8 of the sectional areas shown in Table M.4.

M.9.4 The side horn timbers shall be moulded such that their top edges are not lower than the top edge of the middle horn timber and notched at least 12 mm into the aft deadwood assembly. They shall extend from the transom to the forward end of the aft deadwood.

M.9.5 Siding of side horn pieces shall be 1.25 times the hull planking thickness and permit the planking being fastened with a double row of fastenings.

M.9.6 The cantilever length of the horn timber assembly shall not exceed 60 per cent of the overall length of the side horn timbers.

**M.10 Transom**

M.10.1 Transom planking thickness for single thickness construction shall be obtained from Table M.5.

M.10.2 All types of transoms shall have stiffeners spaced at not greater than 450 mm centres together with substantial margins. The stiffeners and margins shall have scantlings derived from Table M.5.

M.10.3 A substantial grown knee, chock or bracket shall be fitted between the transom and horn timber. Grown knees and chocks shall have a siding equal to 2.5 times the tabular

transom thickness and a moulding in the throat of a grown knee shall be not less than such siding.

M.10.4 Care should be taken in ensuring that any vertical stiffeners are in line with the stringers to facilitate the fitting of the stringer to transom knees, chocks or brackets required by M.15.4 (d) and M.15.4 (f).

#### M.11 Bent or Laminated Frames

M.11.1 The scantlings for bent or laminated frames are to be derived from Table M.6.

M.11.2 Frames are to maintain the same moulding and siding throughout their length and may be checked, if desired, into the hog, apron, forward and aft deadwoods or the horn timbers.

M.11.3 If the basic frame spacing shown in Table M.6 is not adopted, the scantling of the frame shall be adjusted by maintaining the section modulus of the frame per millimetre of frame spacing.

#### M.12 Web Frames

M.12.1 The scantlings for web frames are to be derived from Table M.7. If the basic web frame spacing shown in Table M.7 is not adopted, the scantling of the web frame shall be adjusted by maintaining the section modulus of the frame per millimetre of frame spacing.

M.12.2 Where a web frame is notched in excess of 12.5 per cent of its depth to accommodate longitudinals, the moulding of the web frame shall be increased to maintain the required sectional area in way of the notch.

M.12.3 A floor timber of siding equal to that of the web frame, is to be used to connect the web frame members across the top of the keel and hog (See also M.14.2.).

M.12.4 Gusssets or chocks shall be used to connect the bilge and topside sections of web frames. These shall be of adequate scantling and through fastened by bolts. Where web frames are not in one piece suitable strengthening shall be provided in way of any joint.

M.12.5 Where web frames are used, intermediate frames of dimensions and spacings determined for bent frames are required to be fitted between the web frames.

#### M.13 Floors

M.13.1 Floors shall be in accordance with Table M.8 and associated notes.

M.13.2 The spacing of floors (centre to centre) shall be as follows:

- (i) Machinery spaces: not more than twice the bent frame spacing adopted or the spacing may be three times the frame spacing if the floor siding is increased by 30 per cent of that of normal floors derived from Table M.8.
- (ii) Outside machinery spaces: not more than three times the bent frame spacing adopted.

M.13.3 Special consideration is required to be given in way of machinery installations where the engine sump and/or gearbox is in close proximity to the hog. Details of proposals related to such installations where any interference to the floors is occasioned shall be submitted to the Authority.

M.13.4 Floors in way of machinery beds shall support such beds and all floors should have arm lengths from the centreline of the vessel not less than three times the normal frame spacing.

M.13.5 Where practicable the moulding of the floor should be sufficient for the arms to cover and be fastened to the lower bilge stringers.

#### M.14 Floors in Web Framed Vessels

M.14.1 Floors in web framed vessels shall be sided at twice the single planking thickness shown on Table M.11 and shall be fitted between web frames at not more than 450 mm centres.

M.14.2 Floors connecting web frames across the top of the hog and keel may be equal in siding to the frame being connected except in way of engine rooms where their siding shall be equal to that of the intermediate floors fitted between the web frames.

M.14.3 Where practicable, floors should be of sufficient depth to connect with and be through fastened to the lower bilge stringers.

**M.15 Longitudinal Members**

**M.15.1 Stringers**

- (a) The scantlings of bilge stringers and the number of stringers on each side of the hull shall be determined from Table M.9.
- (b) Stringers may be laminated. Each lamination should be not less than 12 mm in thickness and end joints in laminations shall be at least 9 frame spaces apart.
- (c) Stringers, if not in one length, may be scarphed or lapped. Where a scarph is fitted, its length shall be not less than 6 times the dimension of the face or edge scarphed and it shall be through bolted. (Refer to M.15.4(b)). Where a lapped stringer arrangement is used, the length of overlap, side by side, shall be not less than 9 frame spaces (10 frames).
- (d) In 'wet well' vessels stringer details shall be specially considered.

**M.15.2 Sheer Clamps**

- (a) The recommended scantlings for sheer clamps are given in Table M.10. However, the siding should be not less than 1.5 times hull plank thickness and moulding generally not less than 2 times tabular moulding of deck beam ends given on Table M.12.
- (b) Sheer clamps, if not in one length, may be scarphed and such scarphs shall be not less in length than 6 times the moulding of the sheer clamp fitted, and be edge bolted.

**M.15.3 Beam Shelf**

The beam shelf scantlings are given in Table M.10.

**M.15.4 Fitting of Longitudinal Members**

- (a) Beyond 0.6 L amidships the scantlings of stringers, sheer clamps and beam shelves may be reduced by a uniform taper of both moulding and siding by up to 20 per cent of the cross sectional area shown in the Tables.
- (b) Scarphs in stringers, sheer clamps, beam shelves etc., may not be closer than three times the length of the scarph, measured between the closest extremities of the scarphs considered. Scarphs are not permitted in way of bulkheads, web frames or masts, or in line with keel scarphs. The scarph in a sheer clamp shall not be closer to the butt in a sheer strake than 6 times frame spacing used.
- (c) Sheer clamps and beam shelves in way of raised forecastle decks shall have similar scantlings to those given in Table M.10.
- (d) Bilge stringers and sheer clamps shall be connected to the stem and transom by a grown knee, suitable chock or bracket.
- (e) Breasthooks of grown timber, chocks of straight grain or brackets are to be fitted at the forward end of the hull between the stem and:
  - (i) Sheer clamp; and
  - (ii) Every stringer.
- (f) Grown knees, solid chocks or brackets are required to be fitted between the transom and:
  - (i) Sheer clamp;
  - (ii) Every stringer; and
  - (iii) Hog.
- (g) The siding of the breasthooks, chocks and knees required for M.15.4 (e) and M.15.4 (f) shall be not less than the least dimension of the section of the members being connected. The length of the arms should be not less than 6 x the siding of the knee or connection being used. Bracket scantlings should be specified on plans submitted for approval.

**M.16 Hull Planking**

**M.16.1 Timber**

- (a) The scantling of the hull planking shall be as shown in Table M.11 and associated notes. No plank in a bent frame system shall have a length in metres less than the actual frame spacing in millimetres divided by 80, except from the transom to the next butt forward when the plank length may be reduced subject to approval by the Authority.



- (b) In longitudinally planked web frame systems the minimum length of any plank shall be determined using the method given in M.16.1 (a) and by assuming the frame spacing required for a bent frame vessel of the same length.
- (c) No butts are to be nearer than 1500 mm to each other unless there is a passing strake between when a distance of 1200 mm will be allowed.
- (d) No butts shall be in the same transverse plane unless there are three passing strakes between.
- (e) Butts in garboard strakes shall be clear of keel and hog scarpns (See M.15.4 (b) re sheer clamp).
- (f) Longitudinally planked vessels shall have butt blocks fitted close between frames adjacent to the butt, having a thickness equal to that of the hull planking and a width of overlap on the adjacent strakes of planking by an amount equal to half the thickness of the butt block. The grain of the butt blocks shall run in the longitudinal direction.
- (g) The butts in hull planking shall not be positioned on frames except where the Authority is satisfied that by virtue of frame siding and spacing, and in consideration of the number of fastenings related to the frame scantlings, butts on frames may be permitted.
- (h) Any opening made in the hull planking having a diameter greater than one third of the plank width shall be fitted with an internal doubling or compensator strake in the same manner described in M.16.1 (f). Where more than one plank is cut special consideration will be required by the Authority.
- (i) The width of any strake of hull planking shall not be less than 2 times tabular plank thickness, nor greater than 4 times tabular plank thickness for the 3 strakes in way of the turn of the bilge at amidships, except in edge glued or cold moulded construction in which case the plank widths shall be subject to the approval of the Authority.

## M.17 Decks

### M.17.1 Deck Beams

- (a) Scantlings of ordinary deck beams are not to be less than those determined from Table M.12. and associated notes.
- (b) The scantling tables for deck beams indicate the size of the beam at the centreline of the hull. The moulding at beam ends may be 50 per cent of that at the centreline but in any case shall be not less than the siding of the beam.
- (c) Hatch end beams and carlings are to be sided 30 per cent in excess of the tabular siding for ordinary deck beams where two or more ordinary deck beams are cut.
- (d) Carlings shall have sidings equivalent to deck beams at the ends of deck openings, whilst the moulding shall be equal to that of the deck beam to which the carling is attached.
- (e) Tie bolts of diameters determined from Table M.26 shall be fitted at side decks between the carlings and sheer clamp where:
  - (i) the length of deck opening exceeds 1.80 metres;
  - (ii) the width of such opening exceeds Beam ;
  - (iii) 3 or more normal deck beams are cut; or
  - (iv) otherwise as required by the Authority.
- (f) Where beams are fitted in association with a suitable arrangement of pillars and fore and aft girders the length of beam to be used for Table M.12 shall be the distance between girders or the girder and the side of the vessel.
- (g) Strong beams, or equivalent strengthening, shall be fitted in way of winches, masts and other places where the deck is required to withstand concentrated or above normal loadings. Hanging knees or brackets shall be fitted at the ends of all such beams.
- (h) Lodging knees or brackets shall be fitted at the ends of all main deck beams or beams providing stiffening as described in M.17.1 (g) and also at the corners of deck openings between the carlings and main beams where such openings come within the scope of M.17.1 (e).
- (i) In no case should a notch or housing on the upper side of a deck beam exceed the scantling thickness of plywood decking when derived from Table M.13.
- (j) In no case should a notch on the under side at the end of deck beams exceed 1/5 of the beam moulding (or depth) at the ends.

**M.17.2 Deck Planking**

- (a) Deck planking thickness shall be as obtained from Table M.13 and generally having a siding of not more than twice this thickness. Cover boards and king planks shall be sided at least 1.5 times plank siding, while deck ends are to be jogged into cover boards.
- (b) A shift of butts similar to that required for hull planking in M.16.1 (c) and M.16.1 (d) should be obtained.
- (c) In the case of deck openings referred to in M.17.1 (e) (i) and (ii) the Authority may require additional stiffening and/or increased deck frame scantlings to be incorporated.

**M.17.3 Hanging and Lodging Knees**

- (a) Hanging knees are to be fitted in the following positions:
  - (i) at the ends of all deck beams in way of the deck openings described in M.17.1 (e);
  - (ii) at the ends of strong beams as described in M.17.1 (g); and
  - (iii) at the ends of other beams as may be required by the Authority.
- (b) Hanging knees may be of grown or laminated timber, or fabricated brackets, and the arms shall be not less in length than 3 times the centreline depth of the beam shown in Table M.12. The throat moulding of grown timber knees shall be 40 per cent of the arm length.
- (c) The arms of hanging knees are to be fastened to the deck beams and hull frames with at least 3 bolts of the diameter shown on Table M.26 in each arm. Such fastenings need not pass through decking or planking.
- (d) Lodging knees are required to be fitted in the following positions:
  - (i) at the ends of all deck beams in way of the deck openings described in M.17.1 (c) and (e); and
  - (ii) at the ends of carlings in way of deck openings described in M.17.1 (h).
- (e) The proportions and fastening of lodging knees shall be as for hanging knees and described in M.17.3 (b) and (c) and Table M.26, respectively.

**M.18 Watertight Bulkheads**

**M.18.1 General**

M.18.1.1 Every vessel shall be provided with watertight bulkheads as required by Sub-sections C and D of the Construction Section.

M.18.1.2 Watertight bulkheads may be constructed of timber or steel. Other materials shall be subject to special consideration by the Authority.

M.18.1.3 Watertight bulkheads shall be pierced to the least possible extent, and where they are pierced proper steps shall be taken to maintain their watertight integrity.

M.18.1.4 Any access openings in watertight bulkheads that may be permitted by the Authority shall comply with the requirements of clauses C.66, D.7 and D.8 of the Construction Section. Where stiffeners are cut in way of water-tight doors, the openings are to be framed and bracketed to maintain the full strength of the bulkhead.

**M.18.2 Timber Bulkheads**

M.18.2.1 Timber bulkheads shall be constructed to the scantlings shown in Table M.25. Such bulkheads shall have vertical stiffeners fastened into the grounds and to the deck beams.

M.18.2.2 Bulkheads shall be fitted on substantial timber grounds, or as may be permitted under M.18.2.3. The timber grounds shall be bedded into a non-setting mastic or other material approved for this purpose and be through fastened to the hull planking.

M.18.2.3 The planking on timber bulkheads may be fitted either into rabbets or on to the face of the bulkhead grounds. It may also be fastened to the face of deep or web frames where such frames are fitted and fastened to the hull planking and are not less in size than the scantlings shown in Table M.7 for web frames.

M.18.2.4 Planked bulkheads shall be laid diagonally with two equal thicknesses having a material acceptable to the Authority between these layers.

**M.18.3 Steel Bulkheads**

M.18.3.1 The scantlings of steel bulkheads shall be determined by using Sub-section L of the Construction Section.

M.18.3.2 Steel bulkheads may be fitted to the faces of hull grounds and deck beams in the same vertical plane by means of a boundary angle or directly fastened flat upon the vertical faces. A mastic sealant shall be used between the bulkhead, grounds and deck beams.

M.18.3.3 Where a steel bulkhead is attached to the face of the grounds and deck beams or by a boundary angle, the siding of the grounds shall be 2 times the flange length of the boundary angle, and the moulding equal to that for a timber bulkhead of similar height.

**M.19 Pillars or Stanchions****M.19.1 Pillar Load**

The load on a pillar is to be obtained from the following equation:

$$w = 0.715 bhs \text{ tonnes}$$

where:

w = load in tonnes

b = mean breadth in metres of area supported

s = spacing of pillars in metres

h = height in metres above the deck supported, as defined below:

- (a) h for a pillar below an exposed deck on which cargo is carried is the distance from the deck supported, to a point 3.65 metres above the exposed deck. Where it is intended to carry deck cargoes in excess of 2640 kg /m<sup>2</sup> this head is to be increased in proportion to the added loads which will be imposed on the structure.
- (b) Where tweendeck cargo is carried and its mass is greater or less than 2640 kg/m<sup>2</sup>, h is also to be suitably adjusted.
- (c) h for a pillar below the freeboard deck is to be measured to a point not less than 0.02L + 0.75 metres above the freeboard deck.
- (d) h for a pillar below the superstructure deck is to be measured to a point not less than 0.02L + 0.50 metres above the superstructure deck.

**M.19.2 Permissible Load**

- (a) The permissible load pillar can carry is to be equal to or greater than the pillar load w as determined above. The permissible load may be obtained from the equation:

$$w_a = \frac{A}{1000} \left( 1 - 17 \left( \frac{1}{a} \right) \right) \text{ tonnes}$$

where:

w<sub>a</sub> = Permissible load on the pillar in tonnes

A = Area of the pillar in square millimetres

l = The unsupported length of the pillar in metres

a = The diameter of a circular pillar or the shorter side of a rectangular pillar in millimetres.

Table M.14 gives pillar loadings for a representative selection of round and rectangular pillars.

M.19.3 The scantlings of pillars and stanchions of a material other than timber shall be determined from the appropriate Sub-sections of the Construction Section.

M.19.4 Pillars or stanchions may be placed directly under beams, deck opening corners or deck longitudinals. The spacing of pillars fitted under longitudinals between bulkheads shall not exceed 5 times the beam spacing = 500 mm in the fore and aft direction nor shall they be placed more than 25 per cent of the beam from the vessel's centreline.

M.19.5 Supports under pillars or stanchions are to be of sufficient strength to distribute the loads effectively.

**M.20 Engine Seatings**

M.20.1 The engine seatings are to be of dimensions commensurate with the power of the machinery fitted thereto. They should

- (i) be of a length not less than twice the distance between the extreme holding down bolts;
- (ii) distribute the load over as many transverses as possible;
- (iii) terminate on a substantial transverse member; and
- (iv) be checked over and securely fastened through all transverse floors and the hull planking.

M.20.2 Where the maximum height of a timber engine seating above the top of those floors required by M.13 and M.14 exceeds three times the siding of the seating, then the seating shall be stiffened and supported with side brackets on every second floor. Support shall also be provided between the seatings in way of the side brackets.

**M.21 Deckhouses**

M.21.1 Timber framed deckhouses are required to have substantial scantlings and be adequately fastened to ensure weathertightness.

M.21.2 They should be constructed on trunks or coamings efficiently fastened to carlings and/or deck beams.

M.21.3 Coamings to framed deckhouses shall be not less than 225 mm in height and sided not less than the moulding of the deckhouse framing.

M.21.4 The planking of timber deckhouses shall be not less than that shown in Table M.15. All planking shall be bedded into a mastic sealant if rabbetted into the deckhouse framing.

M.21.5 Deckhouse top beams and covering shall be as shown in Table M.15. A top plate of siding and moulding equal to that for the side stiffeners, shall be fitted for the length of the house.

M.21.6 The scantlings for deckhouses of materials other than timber are to be determined from the appropriate Sub-sections of the Construction Section.

M.21.7 Deckhouses of materials other than timber shall be through fastened to coamings, decking or carlings after bedding in a mastic sealant.

**PART 3—SCANTLINGS FOR HARD CHINE VESSELS**  
**CONTENTS**

<i>Clause</i>	<i>Title</i>
M.22	Keel and hog
M.23	Stem
M.24	Transom
M.25	Web frames
M.26	Intermediate frames in longitudinally planked hard chine vessels
M.27	Floors
M.28	Stringers
M.29	Chines
M.30	Chines for single planked vessels
M.31	Beam shelf/sheer clamp
M.32	Fitting of longitudinal members
M.33	Hull planking
M.34	Deck planking
M.35	Deck beams
M.36	Watertight bulkheads
M.37	Pillars
M.38	Engine seatings
M.39	Deckhouses

---

**PART 3—SCANTLINGS FOR HARD CHINE VESSELS**

*Note:*

Scantlings for double diagonal planked vessels are to be considered under this Part. Scantlings for hard chine, plywood vessels constructed on a system of longitudinal frames, supported by web frames may be derived under the provisions of Part 4.

**M.22 Keel and Hog**

M.22.1 The keel shall be sided and moulded as indicated in Table M.17, except in the case of single planked hard chine displacement vessels when they shall be as indicated in Table M.1. The siding and moulding shown therein may be varied in accordance with the notes to these Tables.

M.22.2 The minimum hog siding and moulding shall be as shown in Table M.17 except in the case of single planked hard chine displacement vessels when they shall be as indicated in Table M.1, but may be varied in accordance with the notes to these Tables.

M.22.3 The keel and hog may be either laminated or of solid timber construction. Where of solid timber construction the keel and hog in vessels less than 10 metres in length shall be in one length, and for vessels 10 metres in length and over where the keel or hog is not in one length it shall be efficiently scarphed.

M.22.4 Where a keel or hog is scarphed, such scarphs shall be in accordance with M.5.4 and M.5.5.

Where the keel and hog are made from one piece of timber or are of glued laminated construction, a reduction in cross sectional area of up to 15 per cent of the total combined areas for the keel and hog, obtained from Table M.17, may be made.

Stopwaters shall be fitted to all centreline construction joints where they intercept the rabbet line.

**M.23 Stem**

M.23.1 Stem scantlings at the heel shall in no case be less in siding and moulding than the scantlings for the keel determined from M.22 and Table M.17.

M.23.2 The scarp of the stem to keel shall not be less than 2.5 times the keel moulding in length.

**M.24 Transom**

M.24.1 Transom thickness shall be obtained from Table M.18 and associated notes, except in the case of single planked hard chine displacement vessels when the transom thickness shall be obtained from Table M.5.

M.24.2 Transoms shall have stiffeners, spaced at not more than 450 mm centres, together with margins. The stiffeners and margins shall have scantlings derived from Table M.18 except in the case of single planked hard chine displacement vessels when the scantlings shall be obtained from Table M.5.

M.24.3 A substantial knee shall be fitted and through bolted through the transom and the hog.

**M.25 Web Frames**

M.25.1 The scantlings for web frames are to be derived from M.12 and Table M.7.

**M.26 Intermediate Frames in Longitudinally Planked Hard Chine Hulls**

M.26.1 Intermediate frames, of dimensions and spacings determined for the frames in round bilge hulls having the same measured length, are required to be provided and fitted between the web frames.

These frames should be housed into the chine a distance of not more than 10 mm for their full cross sectional area and dead nailed to the sheer clamp.

**M.27 Floors**

M.27.1 Floors shall be fitted at each transverse web frame and between web frames at not more than 450 mm centres.

M.27.2 The siding and moulding of floors shall be determined from Table M.19.

M.27.3 Where floors are fitted in the throat of a web frame then the siding may be reduced to that of the web frame, provided the moulding is increased to maintain the section area at the vessel's centreline.

M.27.4 Intermediate floors between web frames shall extend and be fastened to a stringer.

**M.28 Stringers**

M.28.1 The scantlings of bottom stringers shall be determined from Table M.20 and associated notes.

M.28.2 A reduction in scantlings to 60 per cent of the scantlings determined from Table M.20 may be made for side stringers.

M.28.3 Stringers should run for the full length of the vessel wherever possible.

M.28.4 Where practicable, stringers should be in one length. If not in one length stringers shall be scarphed.

M.28.5 Where stringers are scarphed, scarphs shall be not less in length than 6 times the dimension of the edge or face scarphed, and suitably fastened.

M.28.6 Feather edge scarphs shall be suitably fastened and glued.

**M.29 Chines**

M.29.1 The minimum scantlings for chines shall be determined from Table M.21.

M.29.2 The ratio of siding to moulding of chines is generally not to be greater than 1 to 2. In any case the siding shall be sufficient to provide a faying surface equal to 2.5 times the thickness of the bottom planking.

M.29.3 Where practicable, chines should be in one length. If not in one length chines shall be scarphed.

M.29.4 Where chines are scarphed, scarphs shall be not less in length than 6 times the siding and suitably fastened.

M.29.5 The ends of diagonal planking and plywood shall be protected at the chine edge.

#### M.30 Chines for Single Planked Vessels

(a) The dimensions of chines are to be determined from Table M.9.

(b) Where practicable, chines should be in one length, but may be scarphed, in which case the scarphs shall be not less in length than 6 times the moulding and be edge bolted.

#### M.31 Beam Shelf/Sheer Clamp

M.31.1 A suitable beam shelf and/or sheer clamp shall be fitted and the minimum section area shown in Table M.22 is to be maintained.

M.31.2 The siding of the sheer clamp shall be sufficient to maintain faying surfaces equal to twice the deck planking thickness.

#### M.32 Fitting of Longitudinal Members

M.32.1 Beyond 0.6L amidships the scantlings of stringers, chines, sheer clamps and beam shelves may be reduced by a uniform taper of both moulding and siding by up to 20 per cent of the cross sectional area shown in the Tables.

M.32.2 Scarphs in stringers, sheer clamps, beam shelf etc., may not be closer than the web frame spacing, measured between the closest extremities of the scarphs considered. Scarphs are not permitted in way of bulkheads, web frames, or in line with keel scarphs. The scarph in a sheer clamp shall not be closer to the butt in a sheer strake than one web frame spacing.

M.32.3 Breasthooks of grown timber or chocks of straight grain or brackets are to be fitted at the forward end of the hull between the stem and:

- (i) Sheer clamp
- (ii) Chines in vessels of 12.5 metres in length and over.

M.32.4 Grown knees, solid chocks or brackets are required to be fitted between the transom and:

- (i) Sheer clamp
- (ii) Chines in vessels of 12.5 metres in length and over
- (iii) Every second stringer in vessels of 12.5 metres in length and over.

#### M.33 Hull Planking

M.33.1 The hull planking thickness shall be determined in accordance with Table M.23 and associated notes.

M.33.2 Single layer plywood planking shall be provided with butt straps and fastenings in accordance with Table M.24 and associated notes.

M.33.3 Where multiple layers of plywood are used then minimum overlaps, having the same width as the butt straps determined from Table M.24, shall be provided.

M.33.4 Where in double planked fully glued diagonal construction the planking layers are laid parallel to each other, then the overlap between alternate layers shall be not less than 4 times the plank thickness and not more than half the plank width.

#### M.34 Deck Planking

M.34.1 Deck planking thickness shall be determined in accordance with Table M.13 and associated notes.

M.34.2 For single planked decks the planking is generally to have sidings not more than twice the table thickness. Butts shall not be closer than 1500 mm to each other unless there is a passing plank between when a distance of 1200 mm may be allowed.

No butts shall be in the same transverse plane unless there are three passing planks between.

M.34.3 The scantlings of deck longitudinals associated with plywood decks shall be determined in accordance with Table M.27 and associated notes.

#### M.35 Deck Beams

M.35.1 Subject to M.34.3 the scantlings of deck beams shall be determined in accordance with M.17 and Table M.12.

**M.36 Watertight Bulkheads**

M.36.1 The construction of bulkheads shall be determined in accordance with M.18. and the scantlings for timber bulkheads are to be as shown in Table M.25.

**M.37 Pillars**

M.37.1 The scantlings of pillars shall be determined in accordance with M.19 and Table M.14.

**M.38 Engine Seatings**

M.38.1 The installation of engine seatings shall be in accordance with M.20.

**M.39 Deckhouses**

M.39.1 Plywood deckhouses are to have scantlings determined from Table M.15 and associated notes.

M.39.2 Deckhouse framing shall be substantially fastened to the deck framing by through-bolting to carlings, coamings or deck beams.



**PART 4—SCANTLINGS FOR HARD CHINE PLYWOOD HULLS CONSTRUCTED  
ON A SYSTEM OF LONGITUDINAL FRAMES SUPPORTED BY WEB FRAMES**

**CONTENTS**

<i>Clause</i>	<i>Title</i>
M.40	Symbols and units
M.41	Basis for scantlings
M.42	Hull thickness
M.43	Hull stiffening
M.44	Sheer clamp
M.45	Chines
M.46	Beam shelf
M.47	Stringers
M.48	Fitting of longitudinal members
M.49	Web frames
M.50	Floors
M.51	Transom stiffeners
M.52	Transverse and longitudinal deck beams
M.53	Pillars
M.54	Engine seatings
M.55	Plywood bulkheads
M.56	Deckhouses

---

**PART 4—SCANTLINGS FOR HARD CHINE PLYWOOD HULLS CONSTRUCTED  
ON A SYSTEM OF LONGITUDINAL FRAMES SUPPORTED BY WEB FRAMES**

**M.40 Symbols and Units**

M.40.1 In developing scantlings the following symbols and units are used:

- B = Maximum beam (metres)
- D = Depth moulded (metres)
- h = height to deck edge from
  - (i) mid span of the stiffener or frame, for calculation of stiffener or frame scantlings
  - (ii) the middle of the panel between effective stiffeners, for panel thickness
  - (iii) the centre of the longitudinal, for calculation of longitudinal scantlings (milli-  
metres)
- L = water line length (metres)
- e = length of span of frames stiffeners or beams (millimetres)
- P = bottom pressure; determined from Part II Displacement Hulls, or Part III Planing Hulls, of Design Loadings Sub-section, as appropriate (kilopascals)
- S = spacing of stiffeners, frames, beams or floors, measured from centre to centre (milli-  
metres)
- t = thickness of panels (millimetres)
- V = maximum speed (knots)
- Z = modulus of section (millimetres<sup>2</sup>;) )

**M.41 Basis for Scantlings**

M.41.1

	<i>Plywood (MPa)</i>	<i>Timber (MPa)</i>
Working stress (bending) . . . . .	14.0	14.0
Working stress (tensile) . . . . .	11.0	11.0
Modulus of elasticity . . . . .	12500	12500

M.41.2

Where the plywood or timber has a greater bending strength than that given in sub-clause M.41.1, the thickness of plywood may be obtained from the formula:

$$t_2 = t_1 \sqrt{\frac{14}{\text{permissible working stress}}}$$

where:

$t_1$  = thickness calculated in accordance with this Part

$t_2$  = required thickness.

and the modulus of section of frames and stringers from the formula:

$$Z_2 = Z_1 \frac{14}{\text{permissible working strength}}$$

where:

$Z_1$  = modulus calculated in accordance with this Part

$Z_2$  = required modulus.

The permissible working stress is to be taken from Australian Standard 1720-1975. Rules for Use of Timber in Structures (SAA Timber Engineering Code).

**M.42 Hull Thickness**

M.42.1 Bottom Pressure

M.42.1.1 Bottom pressure is to be determined from Part II Displacement Hulls, or Part III Planing Hulls of the Design Loadings Sub-section, as appropriate.

M.42.1.2 Bottom pressure in any case should not be less than 3(L + 6) kPa.

M.42.1.3 Where the rise of floor is less than 12°, the bottom pressure will be specially considered.

M.42.2 Bottom Ply

M.42.2.1 The thickness of plywood from hog to chine is not to be less than the greater of

$$t = 0.018f (125 + P) \frac{S}{100}$$

$$t = 0.021 (160 + 50L + 6V)$$

Where  $f = f_1, f_2$  and  $f_1$  and  $f_2$  are defined in paragraphs M.42.2.2 and M.42.2.3 respectively

M.42.2.2 To correct for aspect ratio, where the aspect ratio of an unstiffened panel  $a/b$  (where  $a$  = length of longer side and  $b$  = length of shorter side) is less than 2, the calculated thickness may be multiplied by the factor  $f_1$ , where:

$$f_1 = 0.6 + 0.2 \frac{a}{b}$$

M.42.2.3 To correct for Breadth of frame, where the frame has a breadth K as shown below greater than  $K = 0.05S$ , the calculated thickness may be multiplied by the factor  $f_2$ , where:

$$f_2 = 1.1 - 2 \left( \frac{K}{S} \right)$$

In no case should  $f_2$  be taken as less than 0.7.

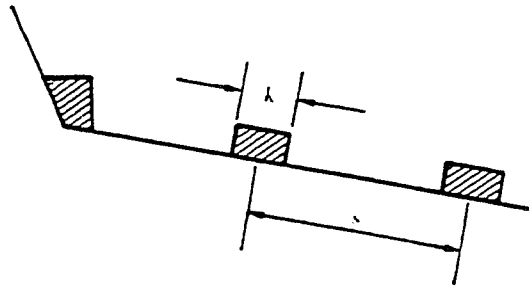

M.42.3 Side Ply

M.42.3.1 The loading P, illustrated below, should be used to determine the thickness of the side plywood where P is the bottom pressure determined from paragraph M.42.1.1 or paragraph M.42.1.2 as appropriate.

M.42.3.2 The pressure to be used is that applicable at the middle of the panel being considered.

M.42.3.3 The thickness of plywood from chine to deck at side is not to be less than the greater of:

$$t = 0.013 f (100 + P_1) \frac{S}{100} \text{ mm}$$

$$t = 0.021 (160 + 50L) \text{ mm}$$

Where  $f = f_1 f_2$  and  $f_1$  and  $f_2$  are as defined in paragraphs M.42.2.2 and M.42.2.3 respectively. In no case shall the thickness be less than 6 mm.

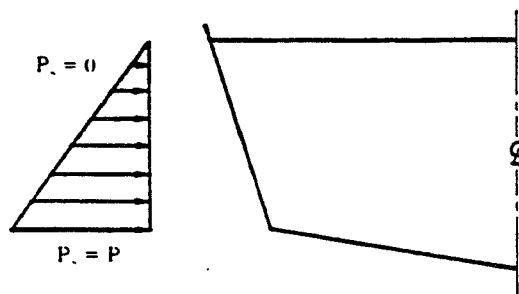

M.42.4 Transom

M.42.4.1 Transoms for carrying outboard engine or stern drive installations

M.42.4.1.1 The thickness of plywood is dependent on the engine power and is to be obtained as follows:

(a) outside the area of attachment of the outboard or stern drive installation, the thickness shall not be less than:

$$t = 0.041 (160 + 50L)$$

(b) in way of the area of attachment of the outboard or stern drive installation, the thickness should not be less than:

$$t = 0.041 (160 + 50L) + a$$

where a is obtained from the following table:

Total installed engine power kW	a. mm
less than 30 . . . . .	20
30 and over but less than 60 . . . . .	25
60 and over but less than 100 . . . . .	30
100 and over but less than 135 . . . . .	35
135 and over but less than 165 . . . . .	45
165 and over . . . . .	to be specially considered

M.42.4.1.2 A substantial knee shall be fitted—

- (a) in the case of an outboard installation, between the transom and the hog,
- (b) in the case of a stern drive installation, between the transom and the engine seatings.

M.42.4.2 Transom not carrying an outboard or stern drive installation

M.42.4.2.1 The thickness of plywood is to be determined from paragraph M.42.3.3.

#### M.42.5 Deck

M.42.5.1 The deck may be supported by transverse beams or by longitudinal stringers or battens in association with deep transverse beams. The deep transverse beams are to be aligned with the side web frames and shall be arranged at the end of deck openings, in the way of masts and posts and under heavy deck fittings. The thickness of the deck is to be increased by doubling pads at stressed corners of deck openings and under masts, posts, deck fittings and heavy loads.

M.42.5.2 The thickness of plywood in the deck of a vessel having length (L) less than or equal to 15 metres shall not be less than:

$$t = 0.036S$$

M.42.5.3 Subject to paragraph M.42.5.4 the thickness of plywood in the deck of a vessel having length (L) greater than 15 metres shall not be less than:

- (a) where the deck is supported by transverse beams

$$t = 0.001 (L + 33)S$$

- (b) where the deck is supported by longitudinals

$$t = 0.001 (L + 18)S$$

M.42.5.4 After applying corrections  $f_1$  and  $f_2$  where appropriate the thickness of plywood in the deck of a vessel having length (L) greater than 15 metres shall in no case be less than

$$t = 2.1 (0.2L + 3)$$

#### M.42.6 Compensation for openings

M.42.6.1 Compensation is to be provided for openings in the side and bottom plywood having a diameter greater than 150mm.

#### M.42.7 Local Reinforcement

M.42.7.1 In the way of hawse pipes, windlasses, gallows, booms and winches, adequate means of protecting the side from the abrasion and impact of equipment lifted by such gallows, booms, winches, windlasses or derricks is to be provided.

M.42.7.2 Where the rise of floor of the bottom of the vessel in way of the propeller is less than 30° additional stiffening is required. Either the frame spacing should be decreased or the thickness of the bottom plywood increased by the following percentages.

<i>Rise of Floor (degrees)</i>	<i>Percentage Increase</i>
30	0
25	10
20	20
15 or less	30

Intermediate values are to be determined by interpolation.

M.42.7.3 Adequate reinforcement shall be provided in way of the attachments of shaft brackets.

### **M.43 Hull Stiffening**

#### **M.43.1 Section Modulus**

M.43.1.1 Section modulus in relation to a frame or stiffener is provided by the member and the panel of plywood to which it is glued and fastened having an effective width of one frame spacing.

M.43.1.2 Section modulus in relation to a web frame, beam or girder supporting stiffeners is provided by the member and an effective width of plywood equal to either half the sum of the spacing on either side of the member or 33 per cent of the unsupported span of the member, whichever is the less. For a member alongside an opening, the effective width of the plywood is equal to either one half the spacing or 16.5 per cent of the unsupported span whichever is less.

M.43.1.3 Section modulus in relation to a member not glued and fastened to the plywood is provided by that member only.

#### **M.43.2 Stem, Keel and Hog**

M.43.2.1 Scantlings for the stem, keel and hog are given in Tables M.2 and M.17 and associated notes, except that in Note (b) (i) of Table M.17, 3 times the plywood thickness should be provided on either side of the keel and in Note (b) (ii) of Table M.17 the moulding should be sufficient to provide 3 times the plywood thickness.

M.43.2.2 The stem, keel or hog may be either of laminated or solid timber construction.

M.43.2.3 A solid keel or hog in vessels 10 metres or less in length shall be of one length and in vessels over 10 metres in length where the keel or hog is not in one length it shall be efficiently scarphed.

M.43.2.4 Where the keel or hog is to be of laminated construction, full details of the glue to be used and the method of laminating must be submitted to the Authority for approval.

M.43.2.5 The keel or hog may be scarphed at one third their respective lengths with at least 10 times the keel moulding given in Table M.17 between the adjacent scarph in the keel and the scarph in the hog.

M.43.2.6 Keel or hog scarphs should be avoided in that portion of the keel and hog extending one engine length forward and aft of the main engine.

M.43.2.7 Keel and hog scarphs shall not be less in length than 6 times the tabular keel moulding or hog moulding respectively. The scarphs shall have nibs of the following depth.

- (a) 0.25 times the depth of the scarph for a moulding not greater than 200mm.
- (b) 0.125 times the depth of the scarph plus 25mm for a moulding greater than 200mm.

M.43.2.8 Stopwaters shall be fitted at all centre line construction joints where they intercept the rabbet line.

M.43.2.9 The scarph of the stem to the keel shall be not less in length than 2.5 times the tabular moulding.

### **M.44 Sheer Clamp**

M.44.1 A suitable sheer clamp shall be fitted and the minimum section as shown in Table M.22 is to be maintained.

M.44.2 The siding and moulding of the sheer clamp shall be sufficient to maintain faying surfaces equal to twice the planking thickness for deck and hull respectively.

**M.45 Chines**

M.45.1 The cross sectional area of the chine batten in millimetres<sup>2</sup> over 0.6L amidships shall not be less than

$$\text{area} = 12.5 t_b^2$$

where  $t_b$  = thickness of bottom plywood.

M.45.2 The ratio of siding to moulding is generally not to be greater than 1 to 2. In any case the siding shall be sufficient to provide a faying surface equal to 2.5 times the thickness of the bottom plywood.

M.45.3 Where practicable, chines should be in one length. If not in one length, chines shall be scarphed.

M.45.4 Where chines are scarphed the length of the scarph shall not be less than 6 times the moulding.

M.45.5 Feather edge scarphs may only be used in vessels less than 15 metres in length. The length of the scarph is to be not less than 6 times the moulding. The scarph is to be glued and fastened.

**M.46 Beam Shelf**

M.46.1 Where a beam shelf is fitted, the section modulus ( $Z$ ) about the horizontal axis is to be not less than

$$Z = 0.045 S^2 B_1$$

where  $B_1$  = span of beam supported.

**M.47 Stringers**

M.47.1 The section modulus of each bottom stringer in association with the plywood to which it is attached, is not to be less than

$$Z = 0.022 \text{ P.S.} \left( \frac{e}{100} \right)^2$$

M.47.2 The section modulus of each side stringer in association with the plywood to which it is attached is not to be less than:

$$Z = 1.1S \left( \frac{h}{1000} + 0.25 \right) \left( \frac{e}{100} \right)^2$$

M.47.3 Where practicable stringers should be in one length. If not in one length, the stringers shall be scarphed or joined by a butt strap.

M.47.4 Where stringers are scarphed the length of scarph shall not be less than 6 times the siding.

M.47.5 Where a butt strap is used, it shall extend the full distance between adjacent web frames and the thickness shall be not less than that of the bottom or side plywood, as is appropriate.

M.47.6 Feather edge scarphs may only be used in vessels less than 15 metres in length. The length of the scarph is to be not less than 6 times the siding. The scarph is to be glued and fastened.

**M.48 Fitting of Longitudinal Members**

M.48.1 Beyond 0.6L amidships the scantlings of the chine and sheer clamp may be reduced by a uniform taper of both moulding and siding up to 20 per cent of the cross sectional area.

M.48.2 Adjacent joints in stringers, chines, sheer clamps and beam shelves, shall not be made closer than the web frame spacing. The distance between the joints is to be measured between the end of one scarph and the commencement of the next.

M.48.3 Joints in longitudinal members are not permitted in way of bulkheads, web frames or in line with keel scarphs.

M.48.4 The scarph in a sheer clamp shall not be closer to a butt in the side plywood than one web frame spacing.

**M.49 Web Frames**

M.49.1 Web frames are to be efficiently connected to floors and are to be aligned with strong full deck beams. The section modulus (Z) of each web frame in association with the plywood to which it is attached is not to be less than:

(a) in the case of a bottom web:

$$Z = 0.026 P.S. \left( \frac{e}{100} \right)^2$$

(b) in the case of a side web:

$$Z = 1.1S \left( \frac{h}{1000} + 0.25 \right) \left( \frac{e}{100} \right)^2$$

In no case shall the siding and moulding of the side web frame be less than 60 per cent of the siding and moulding of the bottom web frame.

**M.50 Floors**

M.50.1 Floors shall be provided at each web frame and between web frames at not more than 450 mm centres.

The depth of floor at centreline shall be 62.5Bmm and the modulus of section at centreline shall be 35 S.D.B.<sup>2</sup>;

M.50.2 Intermediate floors between web frames shall extend and be fastened to a stringer.

**M.51 Transom Stiffeners**

M.51.1 Horizontal stiffeners where fitted, are to be aligned and efficiently connected to side shell stringers. Where the length of a horizontal stiffener exceeds 2 metres, vertical transom stiffeners are to be fitted. Vertical stiffeners are to align with and be efficiently connected to the hog, engine beds, or bottom stringers or efficiently bracketted to the bottom plywood and carried through to the first web frame.

M.51.2 Horizontal stiffeners are to have a section modulus (Z) in association with the plywood to which they are attached, of not less than:

$$Z = 1.1S \left( \frac{h}{1000} + 0.25 \right) \left( \frac{e}{100} \right)^2$$

M.51.3 Vertical stiffeners in association with the plywood to which they are attached are to have a section modulus (Z) of not less than:

$$Z = 1.1S \left( \frac{h}{1000} + 0.25 \right) \left( \frac{e}{100} \right)^2$$

**M.52 Transverse and Longitudinal Deck Beams**

M.52.1 Where the deck is supported as illustrated below, the modulus of section (Z) of each deck longitudinal in association with the plywood to which it is attached, is not to be less than:

$$Z = 25 S \left( \frac{e}{1000} + 1 \right)^2$$

and the modulus of section (Z) of the transverse deck beam is not to be less than:

$$Z = 25 S \left( \frac{e}{1000} + 1 \right)^2$$

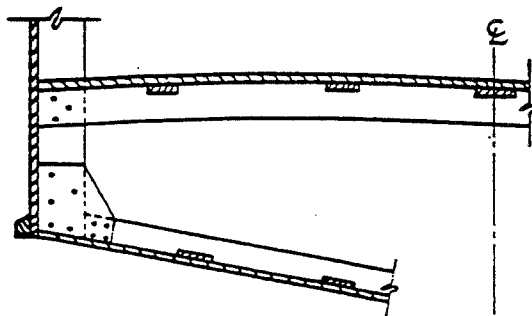

M.52.2 Where the plywood deck is fastened directly to the transverse deck beams without longitudinals, the modulus of section ( $Z$ ) of the beam in association with the deck plywood is not to be less than:

$$Z = 25 S \left( \frac{e}{1000} + 1 \right)^2$$

M.52.3 Heavier beams or supporting pillars shall be fitted under areas of concentrated loads such as masts, winches, fish tanks, windlasses.

M.52.4 The ends of transverse beams are to be aligned with and efficiently connected to side web frames. Where intermediate beams are fitted they are to be supported by a beam shelf and/or sheer clamp and efficiently connected to the side web frames.

### M.53 Pillars

M.53.1 Pillars are to be fitted below masts, winches, windlasses, bollards and other heavy and vibrating deck loads, where no alternate means of support are provided.

M.53.2 The load on a pillar is to be obtained from the following equation:

$$w = 0.715 bhs \text{ tonnes}$$

where:

$w$  = load in tonnes

$b$  = mean breadth in metres of area supported

$s$  = spacing of pillars in metres

$h$  = height in metres above the deck supported as defined below:

- $h$  for a pillar below an exposed deck on which cargo is carried is the distance from the deck supported to a point 3.65 metres above the exposed deck. Where it is intended to carry deck cargoes in excess of 2640 kg/m<sup>2</sup>; this head is to be increased in proportion to the added loads which will be imposed on the structure.
- Where tweendeck cargo is carried and its mass is greater or less than 2640 kg/m<sup>2</sup>;  $h$  is also to be suitably adjusted.
- $h$  for a pillar below the freeboard deck is to be measured to a point not less than  $0.02L + 0.75$  metres above the freeboard deck.
- $h$  for a pillar below the superstructure deck is to be measured to a point not less than  $0.02L + 0.50$  metres above the superstructure deck.

M.53.3 The permissible load a pillar can carry is to be equal to or greater than the pillar load  $w$  as determined above. The permissible load may be obtained from the equation:

$$w_a = \frac{A}{1000} \left( 1 - 17 \left( \frac{1}{a} \right) \right)$$

Where:

$w_a$  = Permissible load on the pillar in tonnes

$l$  = Unsupported length of the pillar in metres

$a$  = Diameter of a circular pillar or shorter side of a rectangular pillar in millimetres.

$A$  = Area of cross section in square millimetres

Table M.14 gives pillar loadings for a representative selection of round and rectangular pillars.

M.53.4 The scantlings of pillars and stanchions or material other than timber shall be determined from the appropriate Sub-sections of the Construction Section.

M.53.5 Pillars or stanchions may be placed directly under beams, deck opening corners or deck longitudinals. The spacing of pillars fitted under longitudinals between bulkheads shall not exceed 5 times the beam spacing plus 500 mm in the fore and aft direction, nor shall they be placed more than 25 per cent of the beam from the vessel's centreline.

M.53.6 Supports under pillars or stanchions are to be of sufficient strength to distribute the loads effectively.



**M.54 Engine Seatings**

M.54.1 The engine seatings are to be of dimensions commensurate with the power of the machinery fitted thereto. They should

- (i) be of a length not less than twice the distance between the extreme engine holding down bolts;
- (ii) distribute the load over as many transverses as possible;
- (iii) terminate on a substantial transverse member; and
- (iv) be checked over and securely fastened through all transverse floors and the hull planking.

M.54.2 Where the maximum height of a timber engine seating above the top of the floors exceeds three times the siding of the seating, then the seating shall be stiffened and supported with side brackets on every second floor. Support shall also be provided between the seatings in way of the side brackets.

**M.55 Plywood Bulkheads**

M.55.1 The thickness of the bulkhead is not to be less than:

$$t = 0.0042 \left( \frac{h}{1000} + \frac{7L}{15} \right) S$$

Where:

h = height of bulkhead at the centreline.

M.55.2 The thickness of the collision bulkhead is not to be less than 25 per cent greater than the thickness given in sub-clause M.55.1.

M.55.3 The bulkhead is to be efficiently fastened to a transverse web frame.

M.55.4 Bulkhead stiffeners on watertight bulkheads in association with the plywood to which they are attached are to have a modulus of section (Z), of not less than:

$$Z = 1.06 \left( \frac{e}{100} \right)^2 \frac{Sh}{1000}$$

Where:

h = height from midpoint of span to top of bulkhead measured at the centreline.

M.55.5 Stiffeners on collision bulkheads are to have a modulus of section (Z) not less than 1.25 times that given in sub-clause M.55.4.

**M.56 Deckhouses**

M.56.1 The thickness of plywood used for the construction of a deckhouse or casing is not to be less than:

- (a) in the case of a deckhouse front:

$$t = 0.0028 S (B + K)$$

- (b) in the case of a deckhouse side or after bulkhead or deckhead:

$$t = 0.0022 S (B + K),$$

where K is derived from:

L	K
Less than 5 metres	3
5 metres and less than 7.5 metres	4
7.5 metres and less than 10.0 metres	5
10 metres and less than 15.0 metres	6
15 metres and over	7

M.56.2 Where the front of the deckhouse is located less than 0.25L from the forward perpendicular, the stiffener spacing is to be reduced by 20 per cent or the thickness of the plywood is to be increased by 25 per cent.

M.56.3 The modulus of section of the stiffener and beams in association with the deck plywood to which they are attached is not be less than:

(a) in the deckhouse front:

$$Z = 33 B S \left( \frac{e}{1000} \right)^2$$

(b) in the case of a deckhouse side or after bulkhead:

$$Z = 19.8 B S \left( \frac{e}{1000} \right)^2$$

(c) in the case of a deckhead:

$$Z = 16.7 S \left( \frac{e}{1000} + 1 \right)^2$$

M.56.4 Deckhouse beams are to be connected to the stiffeners at the side whenever practicable.

**PART 5—SCANTLINGS FOR VESSELS OF SAWN FRAME CONSTRUCTION**

**CONTENTS**

<i>Clause</i>	<i>Title</i>
M.57	General

---

**PART 5—SCANTLINGS FOR VESSELS OF SAWN FRAME CONSTRUCTION**

**M.57 General**

M.57.1 Vessels of sawn frame construction will be specially considered by the Authority.

**PART 6—TABLES****CONTENTS**

M.1	Keel and Hog or Keelson (Single Planked Hulls)
M.2	Stem and Forward Deadwood
M.3	Sternpost and Aft Deadwood
M.4	Horn Timber Assembly
M.5	Transom
M.6	Bent Frames
M.7	Transverse Web Frames
M.8	Floors (Single Planked Hulls)
M.9	Chines and Stringers (Single Planked Hulls)
M.10	Sheer Clamp and Beam Shelf (Single Planked Hulls)
M.11	Hull Planking Thickness
M.12	Deck Beams
M.13	Deck Planking
M.14	Permissible Load on Timber Pillars (Tonnes)
M.15	Deck Houses
M.16	Deck House Beams and Deckhouse Top (Non Working Deck)
M.17	Hard Chine Vessels—Keel and Hog
M.18	Hard Chine Vessels—Transom
M.19	Hard Chine Vessels—Floors
M.20	Hard Chine Vessels—Bottom Stringers
M.21	Hard Chine Vessels—Chines
M.22	Hard Chine Vessels—Beam Shelf/Sheer Clamp
M.23	Hard Chine Vessels—Hull Planking Thickness
M.24	Hard Chine Vessels—Plywood Planking Butt Straps
M.25	Timber Bulkheads
M.26	Fastenings
M.27	Plywood Deck Planking and Associated Deck Longitudinals

**Table M.1**  
**KEEL AND HOG OR KEELSON (SINGLE PLANKED HULLS)**

Measured length	Keel		Hog		Keelson				
	Section area	Siding Moulding	Section area	Siding Moulding	Section area	Siding Moulding			
m	mm <sup>2</sup>	mm	mm	mm <sup>2</sup>	mm	mm	mm <sup>2</sup>	mm	mm
5	7 500	75	100	7 500	150	50	3 850	70	55
6	7 500	75	100	8 750	175	50	5 200	80	65
7	9 375	75	125	11 000	200	55	6 750	90	75
8	12 500	100	125	13 500	225	60	8 500	100	85
9	15 000	100	150	14 625	225	65	10 450	110	95
10	18 750	125	150	17 500	250	70	12 600	120	105
11	26 250	150	175	20 625	275	75	14 950	130	115
12	35 000	175	200	24 000	300	80	17 500	140	125
13	39 375	175	225	25 500	300	85	20 250	150	135
14	45 000	200	225	29 250	325	90	24 000	160	150
15	50 000	200	250	33 250	350	95	27 200	170	160
16	56 250	225	250	37 500	375	100	30 600	180	170
17	68 750	250	275	39 375	375	105	35 100	195	180
18	75 000	250	300	44 000	400	110	38 950	205	190
19	81 250	250	325	48 875	425	115	43 000	215	200
20	89 375	275	325	54 000	450	120	47 250	225	210
21	96 250	275	350	56 250	450	125	51 700	235	220
22	105 000	300	350	61 750	475	130	56 350	245	230
23	112 500	300	375	67 500	500	135	62 475	255	245
24	121 875	325	375	73 500	525	140	67 575	265	255
25	130 000	325	400	79 750	550	145	72 875	275	265
26	140 000	350	400	86 250	575	150	79 750	290	275
27	148 750	350	425	93 000	600	155	85 500	300	285
28	159 375	375	425	96 000	600	160	91 450	310	295
29	168 750	375	450	106 250	625	170	97 600	320	305
30	180 000	400	450	113 750	650	175	100 650	330	315
31	190 000	400	475	121 500	675	180	112 200	340	330
32	212 500	425	500	129 500	700	185	119 000	350	340
33	223 125	425	525	133 000	700	190	126 000	360	350
34	236 250	450	525	141 375	725	195	135 000	375	360
35	247 500	450	550	150 000	750	200	142 450	385	370

## —Notes:

- (a) Keel siding and moulding may be varied provided Section Area is maintained, and the ratio of siding to moulding is not greater than 1 to 1.5.
- (b) Hog siding and moulding may be varied provided Section Area is maintained, and:
- (i) Siding is sufficient for garboard plank landings of at least 1.75 times plank thickness on each side of keel; and
  - (ii) Moulding is sufficient to provide 2.5 times plank thickness.
- (c) Keelson siding and moulding may be varied provided Section Area is maintained, and the ratio of siding to moulding is not greater than 1 to 1.2.

**Table M.2**  
**STEM & FORWARD DEADWOOD**

Measured length	Stem (heel)		Stem (head)		Forward deadwood
	1 Siding	2 Moulding	3 Siding	4 Moulding	
m	mm	mm	mm	mm	mm
5	75	100	60	80	150
6	75	100	60	80	175
7	75	125	60	100	175
8	100	125	80	100	200
9	100	150	80	120	225
10	125	150	100	120	250
11	150	175	120	140	275
12	175	200	140	160	300
13	175	225	140	180	300
14	200	225	160	180	325
15	200	250	160	200	350
16	225	250	180	200	375
17	250	275	200	220	375
18	250	300	200	240	400
19	250	325	200	260	425
20	275	325	220	260	450
21	275	350	220	280	450
22	300	350	240	280	475
23	300	375	240	300	500
24	325	375	260	300	525
25	325	400	260	320	550
26	350	400	280	320	575
27	350	425	280	340	575
28	375	425	300	340	600
29	375	450	300	360	625
30	400	450	320	360	650
31	400	475	320	380	675
32	425	500	340	400	675
33	425	525	340	420	700
34	450	525	360	420	725
35	450	550	360	440	750

\* Forward Deadwood does not include Apron.

**Notes:**

- Stem siding and moulding may be varied provided sectional area is maintained and the ratio of siding to moulding is not greater than 1 to 1.5.
- The stem may be uniformly tapered from heel to the dimensions shown in columns 3 and 4. Where stem siding and moulding are varied in accordance with Note (a) the taper shall be not greater than one fifth of the heel scantlings.
- The face of the stem may be reduced in siding below the declline.
- Laminated stems shall be subject to special consideration.
- Grown knees forming forward deadwoods shall have a moulding of not less than 1.5 times the siding.

**Table M.3**  
**STERNPOST AND AFT DEADWOOD**

<i>Measured length</i>	<i>Sternpost</i>		<i>Aft deadwood</i>	
	<i>*Siding</i>	<i>Moulding</i>	<i>*Siding</i>	<i>Moulding</i>
m	mm	mm	mm	mm
5 . . . . .	75	100	75	
6 . . . . .	75	100	75	
7 . . . . .	75	125	75	
8 . . . . .	100	125	100	
9 . . . . .	100	150	100	
10 . . . . .	125	150	125	
11 . . . . .	150	175	150	
12 . . . . .	175	200	175	
13 . . . . .	175	225	175	
14 . . . . .	200	225	200	
15 . . . . .	200	250	200	
16 . . . . .	225	250	225	
17 . . . . .	250	275	250	
18 . . . . .	250	300	250	
19 . . . . .	250	325	250	
20 . . . . .	275	325	275	
21 . . . . .	275	350	275	
22 . . . . .	300	350	300	
23 . . . . .	300	375	300	
24 . . . . .	325	375	325	
25 . . . . .	325	400	325	
26 . . . . .	350	400	350	
27 . . . . .	350	425	350	
28 . . . . .	375	425	375	
29 . . . . .	375	450	375	
30 . . . . .	400	450	400	
31 . . . . .	400	475	400	
32 . . . . .	425	500	425	
33 . . . . .	425	525	425	
34 . . . . .	450	525	450	
35 . . . . .	450	550	450	

\* Thickness of timber on each side of the shaft tube is to be not less than 0.25 times the keel siding.

*Notes:*

- (a) The sternpost is to be connected to the keel by a mortice and tenon joint and also by a dovetail plate or other equivalent connection on both sides in addition to the fastenings.
- (b) The inner posts, deadwood and/or shaft logs shall be substantially moulded to permit a double row of fastenings in the hood ends coupled with a minimum faying surface of 3 times the planking thickness.
- (c) Where the keel siding has been modified in accordance with Note (a) Table M.1, the sidings of sternposts and aft deadwoods may be uniformly tapered from below the shaft line to the keel.

**Table M.4**  
**HORN TIMBER ASSEMBLY**

<i>Measured length</i>	<i>Sectional area</i>
m	mm <sup>2</sup>
5 . . . . .	8 000
6 . . . . .	10 400
7 . . . . .	12 800
8 . . . . .	15 200
9 . . . . .	17 600
10 . . . . .	20 000
11 . . . . .	24 200
12 . . . . .	28 400
13 . . . . .	32 600
14 . . . . .	36 800
15 . . . . .	41 000
16 . . . . .	48 000
17 . . . . .	55 000
18 . . . . .	62 000
19 . . . . .	69 000
20 . . . . .	76 000
21 . . . . .	83 000
22 . . . . .	90 000
23 . . . . .	97 000
24 . . . . .	104 000
25 . . . . .	111 000
26 . . . . .	118 000
27 . . . . .	125 000
28 . . . . .	132 000
29 . . . . .	139 000
30 . . . . .	146 000
31 . . . . .	153 000
32 . . . . .	160 000
33 . . . . .	167 000
34 . . . . .	174 000
35 . . . . .	181 000



**Table M.5  
TRANSOM**

<i>Measured length</i>	<i>Thick-ness</i>	<i>*Stiffeners</i>		<i>Margin</i>	
		<i>Siding</i>	<i>Mould-ing</i>	<i>Siding</i>	<i>Mould-ing</i>
m	mm	mm	mm	mm	mm
5 . . . . .	28	50	25	75	35
6 . . . . .	30	55	25	80	40
7 . . . . .	32	60	25	85	45
8 . . . . .	34	60	30	90	45
9 . . . . .	36	65	30	95	50
10 . . . . .	38	70	30	100	50
11 . . . . .	40	70	35	105	50
12 . . . . .	42	75	40	110	55
13 . . . . .	44	80	40	120	60
14 . . . . .	46	85	45	125	60
15 . . . . .	48	90	45	130	65
16 . . . . .	50	95	45	140	65
17 . . . . .	52	95	50	145	70
18 . . . . .	54	100	50	150	75
19 . . . . .	56	105	50	160	75
20 . . . . .	58	110	55	165	80
21 . . . . .	60	115	55	170	80
22 . . . . .	62	115	60	180	85
23 . . . . .	64	120	60	185	90
24 . . . . .	66	125	65	190	90
25 . . . . .	68	130	65	200	95
26 . . . . .	70	130	70	205	95
27 . . . . .	72	135	70	210	100
28 . . . . .	74	140	75	220	100
29 . . . . .	76	145	75	225	105
30 . . . . .	78	150	80	230	110
31 . . . . .	80	155	85	235	110
32 . . . . .	82	155	90	245	115
33 . . . . .	84	160	90	250	120
34 . . . . .	86	165	95	255	120
35 . . . . .	88	170	100	260	125

\* Stiffeners spaced at 450 mm centre to centre.

*Notes:*

- (a) Table thickness is for single thickness planked construction. Where diagonal or multiple skin construction is adopted, the thickness may be reduced to 0.75 of that in the table.
- (b) Where stiffener spacing is less than the standard spacing or 450 mm used in the table, stiffener scantlings may be adjusted by maintaining the section modulus of stiffener per millimetre of stiffener spacing. For example:

Vessel 20 m length—propose to use spacing of 300 mm with siding of 100 mm;  
 Modulus per millimetre at table scantlings and spacing = 123

$$\text{Required moulding} = \sqrt{\frac{123 \times 300 \times 6}{100}} = 47 \text{ mm}$$

- (c) Where the stiffener spacing is less than the basic 450 mm the transom thickness may be decreased for every decrease in the resulting space between the stiffeners at the rate of 3 mm per 30 mm decrease.

**Table M.6**  
**BENT FRAMES**

Measured length	Bent frames		
	*Spacing	Siding	Moulding
m	mm	mm	mm
5	100	30	25
6	110	35	25
7	120	40	25
8	130	45	25
9	140	45	25
10	150	50	25
11	160	55	30
12	170	60	30
13	180	65	35
14	190	70	35
15	200	75	40
16	210	80	45
17	220	85	50
18	230	85	55
19	240	90	55
20	250	95	60
21	260	100	60
22	270	105	65
23	280	105	70
24	290	110	70
25	300	115	75
26	310	120	80
27	320	125	85
28	330	125	90
29	340	130	95
30	350	135	95
31	360	140	100
32	370	145	100
33	380	150	105
34	390	155	105
35	400	160	110

\* Spacing is measured from centre to centre of frames.

*Notes:*

- (a) Bent frames may be in unglued laminations, each not less than 12 mm in thickness and fastened with copper nails clenched or rivetted on roves or bolts with nuts and washers. See Table M.26.
- (b) If the frame spacing shown is not used then frame scantlings are to be adjusted by maintaining the section modulus of frame per millimetre of frame spacing. For example—  
Vessel 20 m length—wish to use spacing of 300 mm with siding of 100 mm:  
Modulus per millimetre at table scantlings and spacing = 228

$$\text{Required moulding} = \sqrt{\frac{228 \times 300 \times 6}{100}} = 64 \text{ mm}$$

N.B. Plank thickness will also require increase of 3 mm per 25 mm increase in frame spacing—refer note (a) Table M.11

**Table M.7**  
**TRANSVERSE WEB FRAMES**

<i>Measured length</i>	<i>*Spacing</i>	<i>Web frames</i>	
		<i>Siding</i>	<i>Moulding</i>
m	mm	mm	mm
5. . . . .	500	20	60
6. . . . .	550	25	65
7. . . . .	600	25	75
8. . . . .	650	30	80
9. . . . .	700	30	90
10. . . . .	750	35	95
11. . . . .	800	35	105
12. . . . .	850	40	110
13. . . . .	900	45	120
14. . . . .	950	45	125
15. . . . .	1 000	50	135
16. . . . .	1 050	50	140
17. . . . .	1 100	55	150
18. . . . .	1 150	60	155
19. . . . .	1 200	60	165
20. . . . .	1 250	65	170
21. . . . .	1 300	65	180
22. . . . .	1 350	70	185
23. . . . .	1 400	75	195
24. . . . .	1 450	75	200
25. . . . .	1 500	80	210
26. . . . .	1 550	80	215
27. . . . .	1 600	85	225
28. . . . .	1 650	90	230
29. . . . .	1 700	90	240
30. . . . .	1 750	95	250
31. . . . .	1 800	95	255
32. . . . .	1 850	100	265
33. . . . .	1 900	105	270
34. . . . .	1 950	105	280
35. . . . .	2 000	110	285

\* Spacing is measured from frame centre to frame centre.

*Notes:*

- (a) Where the basic spacing shown in the table is not adopted, frame scantlings are to be adjusted by maintaining the section modulus of the frame per millimetre of frame spacing (Refer to Note (b) Table M.6).
- (b) Frames of the above siding and moulding may be notched to a depth of not more than 12.5 per cent of the moulding to house longitudinal stringers.

**Table M.8**  
**FLOORS (SINGLE PLANKED HULLS)**

<i>Measured length</i>	<i>Floors</i>	
	<i>Siding</i>	<i>Moulding</i>
m	mm	mm
5.	40	100
6.	45	125
7.	45	150
8.	50	150
9.	55	175
10.	60	200
11.	65	225
12.	65	250
13.	70	250
14.	75	275
15.	80	300
16.	85	325
17.	90	325
18.	90	350
19.	95	375
20.	100	400
21.	105	425
22.	110	425
23.	110	450
24.	115	475
25.	120	500
26.	125	525
27.	125	550
28.	130	550
29.	135	575
30.	140	600
31.	145	625
32.	145	650
33.	150	650
34.	155	675
35.	160	700

*Notes:*

- (a) Both fitch and grown floors are to be sided generally 2 times the planking thickness shown for single planked hulls in Table M.11. Sidings are for single planked hulls, and floors shall be fitted at not more than 3 times the bent frame spacing outside the engine room in round bilge hulls.
- (b) Floors in machinery spaces shall be increased in siding by 30 per cent or alternatively may be fitted at 2 times the bent frame spacing.
- (c) Where practicable floors should be of sufficient depth to connect with and be through fastened to the lower bilge stringers.
- (d) For floors in way of web frames refer to M.14.

**Table M.9**  
**CHINES AND STRINGERS (SINGLE PLANKED HULLS)**

<i>Measured length</i>	<i>Chines</i>			<i>Stringers</i>		
	<i>Section area</i>	<i>Siding</i>	<i>Moulding</i>	<i>Section area per side</i>	<i>Siding</i>	<i>Moulding</i>
m	mm <sup>2</sup>	mm	mm	mm <sup>2</sup>	mm	mm
5. . . . .	1 950	30	65	5 400	60	30
6. . . . .	2 450	35	70	5 850	65	30
7. . . . .	3 000	40	75	7 350	70	35
8. . . . .	3 600	45	80	8 400	80	35
9. . . . .	4 250	50	85	9 600	80	40
10. . . . .	4 950	55	90	11 400	95	40
11. . . . .	6 000	60	100	14 175	105	45
12. . . . .	7 150	65	110	14 850	110	45
13. . . . .	8 050	70	115	18 000	120	50
14. . . . .	9 375	75	125	18 750	125	50
15. . . . .	10 800	80	135	22 275	135	55
16. . . . .	12 325	85	145	23 100	140	55
17. . . . .	13 950	90	155	27 000	150	60
18. . . . .	15 675	95	165	31 200	160	65
19. . . . .	17 000	100	170	32 175	165	65
20. . . . .	18 375	105	175	36 750	175	70
21. . . . .	19 800	110	180	37 800	180	70
22. . . . .	21 275	115	185	42 750	190	75
23. . . . .	22 800	120	190	45 000	200	75
24. . . . .	24 375	125	195	49 200	205	80
25. . . . .	26 000	130	200	51 600	215	80
26. . . . .	27 675	135	205	56 100	220	85
27. . . . .	29 400	140	210	62 100	230	90
28. . . . .	31 175	145	215	63 450	235	90
29. . . . .	33 000	150	220	69 825	245	95
30. . . . .	34 875	155	225	72 675	255	95
31. . . . .	36 800	160	230	78 000	260	100
32. . . . .	38 775	165	235	81 000	270	100
33. . . . .	40 800	170	240	88 200	280	105
34. . . . .	42 875	175	245	94 050	285	105
35. . . . .	45 000	180	250	97 350	295	110

*Notes:*

- (a) At least 3 stringers shall be fitted on each side of a round bilge hull and in the bottom of chine hulls. Where more than 3 stringers are fitted their scantlings shall be subject to special consideration by the Authority.
- (b) Stringers may be laminated. Each lamination should be not less than 12mm in thickness (Refer M.15.1 (b)).
- (c) Scantlings of chines and stringers may be reduced from those shown in the table by a uniform taper of both siding and moulding by up to 20 per cent of the cross sectional area beyond 0.6L amidships.

**Table M.10**  
**SHEER CLAMP AND BEAM SHELF (SINGLE PLANKED HULLS)**

<i>Measured length</i>	<i>Sheer clamp</i>		<i>Beam shelf</i>	
	<i>Siding</i>	<i>moulding</i>	<i>Siding</i>	<i>Moulding</i>
m	mm	mm	mm	mm
5	20	115	25	20
6	20	125	30	20
7	25	130	35	25
8	30	135	40	25
9	35	140	50	30
10	40	150	55	35
11	45	155	60	40
12	45	165	65	40
13	50	170	75	45
14	55	175	80	50
15	60	180	85	50
16	65	190	95	55
17	70	195	100	60
18	75	205	105	60
19	75	210	110	65
20	80	215	120	70
21	85	225	125	75
22	90	230	130	75
23	95	235	135	80
24	100	245	145	85
25	105	250	150	90
26	110	255	155	95
27	110	260	160	95
28	115	270	170	100
29	120	275	175	105
30	125	280	180	110
31	130	290	190	110
32	135	295	195	115
33	140	300	200	120
34	145	310	205	120
35	150	315	210	125

*Notes:*

- (a) Scantlings of sheer clamp and beam shelf may be reduced by a uniform taper of both moulding and siding by up to 20 per cent of the sectional area beyond 0.6L amidships.
- (b) Sheer clamps and beam shelves in way of raised decks, etc., shall have scantlings as shown in the Table.

Table M.11  
HULL PLANKING THICKNESS

Measured length	Single planked	Multiple skins (total)			Marine plywood
		2 Layers	3 Layers	4 Layers	
m	mm	mm	mm	mm	mm
5	18	15	15	15	9
6	20	17	17	17	11
7	22	19	19	18	12
8	24	21	20	19	14
9	26	23	22	21	15
10	28	25	24	23	16
11	30	26	25	24	18
12	32	28	27	25	20
13	34	30	29	27	21
14	36	32	30	28	22
15	38	34	32	30	24
16	40	36	34	32	25
17	42	38	36	33	27
18	44	40	37	34	28
19	46	42	39	36	30
20	48	44	41	38	31
21	50	45	42	39	33
22	52	47	44	41	34
23	54	49	46	42	36
24	56	51	47	43	37
25	58	53	49	45	39
26	60	55	51	46	40
27	62	57	53	48	42
28	64	59	54	49	43
29	66	60	56	51	45
30	68	62	58	53	46
31	70	64	59	54	48
32	72	66	61	56	50
33	74	68	63	57	51
34	76	70	65	59	52
35	78	72	66	60	54

*Notes:*

- (a) Where frame spacing differs from the basic frame spacings shown in Table M.6, planking thickness shall be increased and may be decreased for every increase or decrease respectively in the resulting span between frames as follows:
  - (i) Bent frames—3 mm per 25 mm difference
  - (ii) Other frame types—3 mm per 30 mm difference
- (b) Plywood may be in multiple thicknesses to obtain the total thickness shown in the right hand column of the Table.
- (c) Table thicknesses for multiple skins are applicable only to hulls where planking layers are glued together.

40 Section 5 Sub-section M

- (d) Where multiple skins are not glued together the total thickness shall be as for single planking, however, where the multiple skins are laid diagonally and not glued together the total thickness shall be 90 per cent of the Table thickness for single planking.
- (e) The Table scantlings are for hardwood of 960kg/m<sup>3</sup> density and marine grade plywood to Australian Standard AS 2272-1979, Plywood For Marine Craft.

Table M.12  
DECK BEAMS

* Length of beam	Deck beams			
	Spacing	Siding	Moulding (mid-span)	Moulding (ends)
m	mm	mm	mm	mm
1. . . . .	250	25	35	25
1.5 . . . . .	275	35	45	35
2.0 . . . . .	300	40	60	40
2.5 . . . . .	325	50	75	50
3.0 . . . . .	350	50	90	50
3.5 . . . . .	375	65	110	65
4.0 . . . . .	400	70	130	70
4.5 . . . . .	425	80	155	80
5.0 . . . . .	450	90	175	90
5.5 . . . . .	475	100	200	100
6.0 . . . . .	500	110	225	110
6.5 . . . . .	525	120	250	125
7.0 . . . . .	550	130	275	140
7.5 . . . . .	575	140	300	150
8.0 . . . . .	600	150	325	160

\* See notes (b) and (c) for determination of length of beam.

Notes:

- (a) Basic spacing is from beam centre to beam centre.
- (b) Length of beam shall be the breadth of the vessel at the position of the beam.
- (c) Length of beam when pillars and girders are fitted is to be determined from sub-clause M.17.1 (f).
- (d) If basic spacing is increased or decreased then the section modulus at mid-span of the beam shall be increased or may be decreased respectively in the same proportion.
- (e) If the table dimensions for siding and moulding are varied then the section modulus is to be maintained.

M not to exceed  $3 \lambda s$   
 Note: section modulus  $Z = S \times M^2/6$   
 where S = siding in mm  
 M = moulding in mm

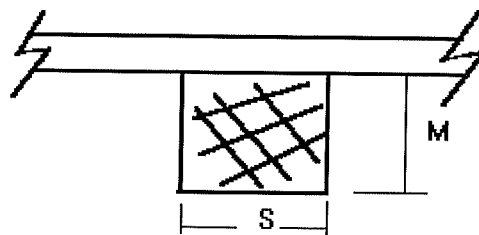



Table M.13  
DECK PLANKING

<i>Measured Length</i>	<i>Deck planking</i>	
	<i>Single planked</i>	<i>Plywood</i>
m	mm	mm
5. . . . .	25	10
6. . . . .	25	10
7. . . . .	26	12
8. . . . .	28	14
9. . . . .	30	16
10. . . . .	32	18
11. . . . .	34	20
12. . . . .	36	22
13. . . . .	38	24
14. . . . .	42	26
15. . . . .	44	28
16. . . . .	46	30
17. . . . .	48	32
18. . . . .	50	34
19. . . . .	52	36
20. . . . .	54	38
21. . . . .	56	40
22. . . . .	58	42
23. . . . .	60	44
24. . . . .	64	46
25. . . . .	66	48
26. . . . .	68	50
27. . . . .	70	52
28. . . . .	72	54
29. . . . .	74	56
30. . . . .	76	58
31. . . . .	78	60
32. . . . .	80	62
33. . . . .	84	64
34. . . . .	86	66
35. . . . .	88	68

*Notes:*

- (a) Where beam spacing differs from the basic beam spacings shown in Table M.12, planking thickness shall be increased and may be decreased for every increase or decrease respectively in the resulting span between beams as follows:
  - (i) Single planked—3 mm per 25 mm difference.
  - (ii) Plywood—3 mm per 50 mm difference
- (b) Plywood may be in multiple thicknesses to obtain the total thickness shown in the right hand column of the table.
- (c) The table scantlings are for softwood of 640 kgs/m<sup>2</sup> density and marine grade plywood to Australian Standard AS 2272-1979, Plywood For Marine Craft.

**Table M.14**  
**PERMISSIBLE LOAD ON TIMBER PILLARS**  
 (Tonnes)

a (mm)	<i>Unsupported length of pillar (m)</i>							
	<i>Rectangular section</i>				<i>Round section</i>			
	<i>1</i>	<i>2</i>	<i>3</i>	<i>4</i>	<i>1</i>	<i>2</i>	<i>3</i>	<i>4</i>
50	1.7	0.8	..	..	1.3	0.6	..	..
60	2.6	1.6	0.5	..	2.0	1.2	0.4	..
70	3.7	2.5	1.3	..	2.9	2.0	1.0	..
80	5.0	3.7	2.3	1.0	4.0	2.9	1.8	0.8
90	6.6	5.0	3.5	2.0	5.2	4.0	2.8	1.6
100	8.3	6.6	4.9	3.2	6.5	5.2	3.8	2.5
110	10.2	8.4	6.5	4.6	8.0	6.6	5.1	3.6
120	12.4	10.3	8.3	6.2	9.7	8.1	6.5	4.9
130	14.7	12.5	10.3	8.1	11.5	9.8	8.1	6.3
140	17.2	14.8	12.5	10.1	13.5	11.7	9.8	7.9
150	20.0	17.4	14.9	12.3	15.7	13.7	11.7	9.7
160	22.9	20.2	17.4	14.7	18.0	15.8	13.7	11.6
170	26.0	23.1	20.2	17.3	20.4	18.2	15.9	13.6
180	29.3	26.3	23.2	20.2	23.0	20.6	18.2	15.8
190	32.9	29.6	26.4	23.2	25.8	23.3	20.7	18.2
200	36.6	33.2	29.8	26.4	28.7	26.1	23.4	20.7

*Note:* In the above table a is the shorter side of a rectangular pillar or, the diameter of a circular pillar in millimetres.

**Table M.15**  
**DECK HOUSES**

<i>Measured length</i>	<i>Deck house framing</i>					
	<i>Plywood</i>		<i>Planking</i>	<i>Spacing</i>	<i>Siding</i>	<i>Moulding</i>
<i>Sides</i>	<i>Front</i>	<i>mm</i>				
m	mm	mm	mm	mm	mm	mm
5	6	6	16	380	38	50
6	6	6	16	380	38	50
7	6	9	16	380	38	50
8	9	9	16	400	38	50
9	9	9	16	400	50	80
10	9	12	17	400	50	80
11	9	12	17	400	50	80
12	9	12	18	400	50	80
13	9	12	19	400	50	80
14	9	12	20	400	50	80
15	9	12	21	400	50	80
16	12	16	22	420	50	80
17	12	16	23	420	50	80
18	12	16	24	420	50	100
19	12	16	25	420	50	100
20	12	16	26	420	50	100
21	12	16	27	420	50	100
22	12	16	28	420	50	100
23	12	16	29	440	50	100
24	16	18	30	440	50	100
25	16	18	31	440	50	100
26	16	18	32	440	60	120
27	16	18	33	440	60	120
28	16	18	34	440	60	120
29	16	18	35	440	60	120
30	16	22	36	460	60	120
31	16	22	37	460	60	120
32	16	22	38	460	60	120
33	18	22	38	460	60	120
34	18	22	38	460	60	120
35	18	22	38	460	60	120

**Notes:**

- (a) Where the basic spacing shown in the table is not adopted, frame scantlings are to be adjusted by maintaining the section modulus of the frame per millimetre of frame spacing (Refer to Note (b) Table M.6).
- (b) Where frame spacing differs from the basic frame spacings shown in Table M.6, planking thickness shall be increased and may be decreased for every increase or decrease respectively in the resulting span between frames as follows:
- (i) Bent frames—3 mm per 25 mm difference
  - (ii) Other frame types—3 mm per 30 mm difference.

**Table M.16**  
**DECK HOUSE BEAMS AND DECK HOUSE TOP (NON WORKING DECK)**

<i>Length of beam</i>	<i>Deck house beams</i>			<i>Deck house top</i>	
	<i>Spacing</i>	<i>Siding</i>	<i>Moulding</i>	<i>Plywood</i>	<i>Planking</i>
m	mm	mm	mm	mm	mm
1.5 . . . . .	350	30	54	9	12
2 . . . . .	350	35	70	9	13
3 . . . . .	350	45	100	9	15
4 . . . . .	400	60	140	12	17
5 . . . . .	400	75	180	12	19
6 . . . . .	400	90	200	12	21
7 . . . . .	450	100	220	16	23
8 . . . . .	450	100	240	16	25

*Notes:*

- (a) Basic spacing is from beam centre to beam centre.
- (b) Length of beam shall be the breadth of the deck house at the position of the beam.
- (c) Length of beam when pillars and girders are fitted is to be determined from M.17.1(f).
- (d) If basic spacing is increased or decreased then the section modulus at mid-span of the beam shall be increased or may be decreased respectively in the same proportion.
- (e) If the table dimensions for siding and moulding are varied then the section modulus is to be maintained

$$\left( \text{Section modulus } Z = \frac{S \times M^2}{6} \right)$$

- (f) Where it is intended that the deck house top be used as a working deck then scantlings shall be taken from Tables M.12 and M.13 and associated Notes.
- (g) Where beam spacing differs from the basic beam spacings shown in the Table planking thickness shall be increased and may be decreased for every increase or decrease respectively in the resulting span between beams as follows:
  - (i) Single planked—3 mm per 25 mm difference
  - (ii) Plywood—3 mm per 50 mm difference.

**Table M.17**  
**HARD CHINE VESSELS—KEEL AND HOG**

<i>Measured length</i>	<i>Keel</i>			<i>Hog</i>		
	<i>Section area</i>	<i>Siding</i>	<i>Moulding</i>	<i>Section area</i>	<i>Siding</i>	<i>Moulding</i>
m	mm <sup>2</sup>	mm	mm	mm <sup>2</sup>	mm	mm
5	7 350	70	105	4 200	120	35
6	8 625	75	115	5 400	135	40
7	10 625	85	125	6 750	150	45
8	12 150	90	135	8 250	165	50
9	14 250	95	150	9 900	180	55
10	16 800	105	160	10 725	195	55
11	18 700	110	170	12 600	210	60
12	21 600	120	180	14 625	225	65
13	23 750	125	190	16 800	240	70
14	27 000	135	200	19 125	255	75
15	29 400	140	210	20 250	270	75
16	33 750	150	225	22 800	285	80
17	36 425	155	235	25 500	300	85
18	40 425	165	245	28 800	320	90
19	44 200	170	260	31 825	335	95
20	48 600	180	270	35 000	350	100
21	51 800	185	280	36 500	365	100
22	56 550	195	290	39 900	380	105
23	60 000	200	300	43 450	395	110
24	65 100	210	310	47 150	410	115
25	68 800	215	320	50 400	420	120

*Notes:*

- (a) Keel siding and moulding may be varied provided section area is maintained and siding is sufficient to provide 0.25 times the table siding on each side of the shaft tube.
- (b) Hog siding and moulding may be varied provided section area is maintained, and
  - (i) Siding is sufficient for garboard plank landings of at least 1.75 times plank thickness on either side of keel; and
  - (ii) Moulding is sufficient to provide 2.5 times plank thickness.
- (c) Vessels over 25 metres measured length will be specially considered by the Authority.

**Table M.18**  
**HARD CHINE VESSELS—TRANSOM**

<i>Measured length</i>	<i>Thickness plywood</i>	<i>*Stiffeners</i>		<i>Margin</i>	
		<i>Moulding</i>	<i>Moulding</i>	<i>Siding</i>	<i>Moulding</i>
m	mm	mm	mm	mm	mm
5	12	50	25	75	35
6	12	55	25	80	40
7	12	60	25	85	45
8	12	60	30	90	45
9	16	65	30	95	50
10	16	70	30	100	50
11	19	70	35	105	50
12	19	75	40	110	55
13	19	80	40	120	60
14	24	85	45	125	60
15	24	90	45	130	65
16	24	95	45	140	65
17	24	95	50	145	70
18	24	100	50	150	75
19	24	105	50	160	75
20	24	110	55	165	80
21	30	115	55	170	80
22	30	115	60	180	85
23	30	120	60	185	90
24	30	125	65	190	90
25	30	130	65	200	95

\* Stiffeners spaced at 450mm centre to centre..

*Notes:*

- (a) Where planking is used table thickness is to be increased by 25 per cent.
- (b) Where stiffener spacing varies from the standard spacing of 450mm used in the table, stiffener scantlings are to be adjusted by maintaining the section modulus of the stiffener per millimetre of stiffener spacing (Refer to Note (b) Table M.6).
- (c) Transom thickness may be decreased if the stiffener spacing is less than the basic 450mm as follows:
  - (i) Plywood—3mm per 50mm
  - (ii) Planking—3mm per 30mm.
- (d) Plywood may be in multiple thicknesses to obtain the total thickness shown in the table.
- (e) The table scantlings are for hardwood of 960 kg/m<sup>3</sup> density and marine grade water-proof plywood to Australian Standard AS 2272-1979, Plywood for Marine Craft.
- (f) Vessels over 25 metres measured length will be specially considered by the Authority.

**Table M.19**  
**HARD CHINE VESSELS—FLOORS**

<i>Measured length</i>	<i>*Floors</i>	
	<i>Siding</i>	<i>Moulding at centre line</i>
m	mm	mm
5	35	90
6	35	100
7	40	110
8	40	120
9	45	130
10	50	140
11	50	150
12	55	160
13	60	180
14	60	190
15	65	200
16	70	210
17	70	220
18	75	230
19	80	250
20	80	260
21	85	270
22	90	280
23	90	290
24	95	300
25	100	310

\* Floors spaced at 450mm centres.

*Notes:*

- (a) Where floor spacing is less than 450mm, floor scantlings may be adjusted by maintaining the section modulus of the floor at the vessel's centre line per millimetre of floor spacing (Refer to Note (b) Table M.6).
- (b) Vessels over 25 metres measured length will be specially considered by the Authority.

**Table M.20**  
**HARD CHINE VESSELS—BOTTOM STRINGERS**

<i>Measured Length</i>	<i>Bottom stringers</i>			
	<i>Spacing</i>	<i>Total section area per side</i>	<i>Moulding</i>	<i>Siding</i>
m	mm	mm <sup>2</sup>	mm	mm
5. . . . .	215	2 760	20	46
6. . . . .	245	4 032	24	56
7. . . . .	270	5 544	28	66
8. . . . .	295	7 056	28	84
9. . . . .	260	8 448	32	66
10. . . . .	280	9 728	32	76
11. . . . .	300	11 248	38	74
12. . . . .	320	12 464	38	82
13. . . . .	280	14 060	38	74
14. . . . .	300	15 580	38	82
15. . . . .	325	17 200	40	86
16. . . . .	345	18 400	40	92
17. . . . .	310	20 160	40	84
18. . . . .	330	21 600	40	90
19. . . . .	340	22 680	42	90
20. . . . .	355	24 192	42	96
21. . . . .	325	25 872	42	88
22. . . . .	340	27 048	42	92
23. . . . .	355	28 336	44	92
24. . . . .	370	30 184	44	98
25. . . . .	385	31 416	44	102

*Notes:*

- (a) Where stringer spacing varies from the table, stringer scantlings are to be adjusted by maintaining the section modulus of stringer per millimetre of stringer spacing (Refer Note (b) Table M.6).
- (b) Where the spacing of web frames supporting bottom or side stringers varies from the table spacing in Table M.7, the scantlings of stringers shall be increased or may be decreased for any increase or decrease respectively in web frame spacing by increasing or decreasing the section modulus in accordance with the formula:

$$Z_1 = Z \left( \frac{S_1}{S_2} \right)$$

Where Z = section modulus of table stringer as adjusted for stringer spacing, if applicable.

Z = required section modulus at new spacing

S = table spacing for web frames

S = new spacing for web frames

- (c) Vessels over 25 metres measured length will be specially considered by the Authority.



Table M.21  
HARD CHINE VESSELS—CHINES

<i>Measured length</i>	<i>Sectional area</i>	<i>Siding</i>	<i>Moulding</i>
m	mm <sup>2</sup>	mm	mm
5. . . . .	1 458	27	54
6. . . . .	1 800	30	60
7. . . . .	2 312	34	68
8. . . . .	2 628	36	73
9. . . . .	3 200	40	80
10. . . . .	3 872	44	88
11. . . . .	4 560	48	95
12. . . . .	5 354	52	104
13. . . . .	6 272	56	112
14. . . . .	6 844	58	118
15. . . . .	7 688	62	124
16. . . . .	8 712	66	132
17. . . . .	9 248	68	136
18. . . . .	10 366	72	144
19. . . . .	10 952	74	148
20. . . . .	12 168	78	156
21. . . . .	12 800	80	160
22. . . . .	13 440	82	164
23. . . . .	14 450	85	170
24. . . . .	15 480	88	176
25. . . . .	16 200	90	180
26. . . . .	17 200		
27. . . . .	18 200		
28. . . . .	19 200		
29. . . . .	20 200		
30. . . . .	21 200	To the satisfaction of the Authority concerned	
31. . . . .	22 200		
32. . . . .	23 200		
33. . . . .	24 200		
34. . . . .	25 200		
35. . . . .	26 200		

**Table M.22**  
**HARD CHINE VESSELS—BEAM**  
**SHELF/SHEER CLAMP**

<i>Measured length</i>	<i>Section area</i>
m	mm <sup>2</sup> :
5 . . . . .	2 300
6 . . . . .	2 500
7 . . . . .	3 250
8 . . . . .	4 050
9 . . . . .	4 900
10 . . . . .	6 000
11 . . . . .	6 970
12 . . . . .	7 420
13 . . . . .	8 500
14 . . . . .	9 620
15 . . . . .	10 800
16 . . . . .	12 350
17 . . . . .	13 650
18 . . . . .	15 370
19 . . . . .	15 750
20 . . . . .	17 200
21 . . . . .	19 120
22 . . . . .	20 700
23 . . . . .	22 320
24 . . . . .	24 500
25 . . . . .	26 250

*Note:*

- (a) Vessels over 25 metres measured length will be specially considered by the Authority.

**Table M.23**  
**HARD CHINE VESSELS—HULL PLANKING THICKNESS**

<i>Measured length</i>	<i>Bottom</i>		<i>Topside</i>	
	<i>Plywood</i>	<i>Double diagonal</i>	<i>Plywood</i>	<i>Double diagonal</i>
m	mm	mm	mm	mm
5 . . . . .	9	15	9	15
6 . . . . .	11	17	9	15
7 . . . . .	12	19	9	15
8 . . . . .	14	21	11	16
9 . . . . .	15	23	11	18
10 . . . . .	16	25	12	19
11 . . . . .	18	26	14	20
12 . . . . .	20	28	15	21
13 . . . . .	21	30	16	23
14 . . . . .	22	32	17	24
15 . . . . .	24	34	18	26
16 . . . . .	25	36	19	27
17 . . . . .	27	38	20	29
18 . . . . .	28	40	21	30
19 . . . . .	30	42	22	32
20 . . . . .	31	44	23	33
21 . . . . .	33	45	25	34
22 . . . . .	34	47	26	36
23 . . . . .	36	49	27	37
24 . . . . .	37	51	28	39
25 . . . . .	39	53	29	40

*Notes:*

- (a) Where stringer spacing differs from the basic stringer spacings shown in Table M.20, planking thickness shall be increased and may be decreased for every increase or decrease respectively in the resulting span between stringers as follows:
  - (i) Plywood—3 mm per 50 mm difference
  - (ii) Diagonal planking—3 mm per 30 mm difference.
- (b) Plywood may be in multiple thicknesses to obtain the total thickness shown in the table.
- (c) the table scantlings are for hardwood of 960 kg/m<sup>3</sup> density and marine grade water-proof plywood to Australian Standard AS 2272-1979 Plywood for Marine Craft.
- (d) Table thicknesses for double diagonal planking are applicable only to hulls where planking layers are glued together.
- (e) Vessels over 25 metres measured length will be specially considered by the Authority.

**Table M.24**  
**HARD CHINE VESSELS—PLYWOOD PLANKING BUTT STRAPS**

<i>Plywood planking thickness</i>	<i>Breadth of butt strap</i>	<i>Fastings</i>	
		<i>Method of fastening</i>	<i>Copper boat nails</i>
mm	mm		S.W.G.
6 . . . . .	175		12
9 . . . . .	225	Double	12
12 . . . . .	250	fastened	12
16 . . . . .	300		10
19 . . . . .	325	Treble	10
24 . . . . .	375	fastened	8

*Notes:*

- (a) Where multiple layers of plywood are used butt straps are not required to be fitted, however overlaps having a minimum width equal to the table width for butt straps shall be provided.
- (b) Butt straps should not be fitted in the bottom or side plywood planking in any of the machinery space.

**Table M.25**  
**TIMBER BULKHEADS**

<i>Height of bulkhead</i>	<i>Planking</i>		<i>Stiffener</i>		
	<i>Double planked</i>	<i>Ply-wood</i>	<i>Stiff-ener spacing</i>	<i>Mould-ing</i>	<i>Siding</i>
m	mm	mm	mm	mm	mm
1.0 . . . . .	20	10	400	70	35
1.5 . . . . .	30	15	400	85	45
2.0 . . . . .	40	20	400	100	55
2.5 . . . . .	50	25	450	115	65
3.0 . . . . .	60	30	450	135	75
3.5 . . . . .	70	35	450	150	85
4.0 . . . . .	80	40	450	165	95

*Notes:*

- (a) The height of the bulkhead is to be measured from the top of the keel to the underside of the deck beam at the centre line of the vessel.
- (b) Where stiffener spacing differs from the basic stiffener spacings shown in the Table planking thickness shall be increased and may be decreased for every increase or decrease respectively in the resulting span between stiffeners as follows:
- (i) Planking—3 mm per 30 mm difference
  - (ii) Plywood—3 mm per 50 mm difference.

- (c) If the stiffener spacing shown in the table is not used then the stiffener scantlings are to be adjusted by maintaining the section modulus of stiffener per millimetre of stiffener spacing (Refer Note (b) Table M.6).
- (d) In the case of a collision bulkhead the table planking thickness is to be increased by 25 per cent and the section modulus of the stiffener is to be not less than 1.25 times the table modulus.
- (e) Where collision bulkhead stiffeners are glued and fastened to the bulkhead, the required increase, based on the section modulus will be specially considered.

Table M.26  
FASTENINGS

Thickness of member being fastened	Copper nails	Screws	Bolts	
	Gauge	Gauge	Total thickness of members being joined	Diameter
mm	BG	No.	mm	mm
18-22. . . . .	12	4-6	150-200	9
22-26. . . . .	11	6-8	200-300	12
26-30. . . . .	10	8-10	300-380	16
30-34. . . . .	9	10-12	380-600	19
34-38. . . . .	8	12-14	600 and over	22
38-42. . . . .	7	14-16		
42-46. . . . .	6	16-18		
46-50. . . . .	5	16-18		
50-54. . . . .	4	16-18		
54-58. . . . .	3			
58-70. . . . .	2			
70-80. . . . .	1			

*Note:*

Minimum plank fastenings at frames shall be as follows:

- less than 150mm width of plank double fastened
- 150mm and over width of plank treble fastened.

The bolt sizes are based on the use of copper having an ultimate strength of 210 MPa.

For bolts of materials other than copper the diameter may be determined from the formula:

$$\text{diameter} = d_c \times \sqrt[3]{\frac{210}{U}}$$

where  $d_c$  = diameter of copper bolt

$U$  = ultimate strength of other material

**Table M.27**  
**PLYWOOD DECK PLANKING AND ASSOCIATED DECK LONGITUDINALS**

Plywood thickness	Deck longitudinals		
	Spacing	Siding	Moulding
6 . . . . .	140	30	45
8 . . . . .	180	30	50
10 . . . . .	230	40	50
12 . . . . .	270	40	54
14 . . . . .	310	40	58
16 . . . . .	350	40	62
18 . . . . .	395	45	62
20 . . . . .	435	45	64
22 . . . . .	465	45	68
24 . . . . .	510	50	68
26 . . . . .	550	50	70
28 . . . . .	595	55	70
30 . . . . .	635	55	72

*Notes:*

- (a) Deck longitudinal spacing is measured centre to centre.
- (b) Section Modulus of deck longitudinals in the Table is for longitudinals associated with web beams spaced 1000mm apart. Where spacing of web beams varies from 1000mm then the scantlings of longitudinals shall be increased or may be decreased for any increase or decrease respectively in web beam spacing by increasing or decreasing the section modulus in accordance with the formula

$$Z_1 = Z \left( \frac{S}{1000} \right)^2$$

where Z = section modulus of Table longitudinals as adjusted for longitudinal spacing, if applicable

Z<sub>1</sub> = required section modulus (refer note (e) Table M.12)

- (c) Where longitudinal spacings varies from the table, longitudinal scantlings are to be adjusted by maintaining the section modulus of the longitudinal per millimetre of longitudinal spacing (Refer Note (b) Table M.6)
- (d) Deck thickness shall be increased and may be decreased for every increase or decrease respectively in the table spacing by an amount of 3mm for each 50mm difference.

**PART 7—FIGURES**

**CONTENTS**

<i>No.</i>	<i>Title</i>
M.1	Profile
M.2	Typical Section, Chine Hull
M.3	Isometric view
M.4	Typical Web Frame Construction, Chine Hull
M.5	Common Forms of Scarphs
M.6	Typical Stem Assembly
M.7	Alternative Typical Stem Assembly
M.8	Typical Deadwood Aft
M.9	Typical Deadwood Aft
M.10	Typical Deadwood Aft
M.11	Typical Midship Section, Bilge Hull Type
M.12	Scarphing and Lapping of Longitudinals
M.13	Typical Butt Block in Hull Plank

PROFILE

Fig. M.1.

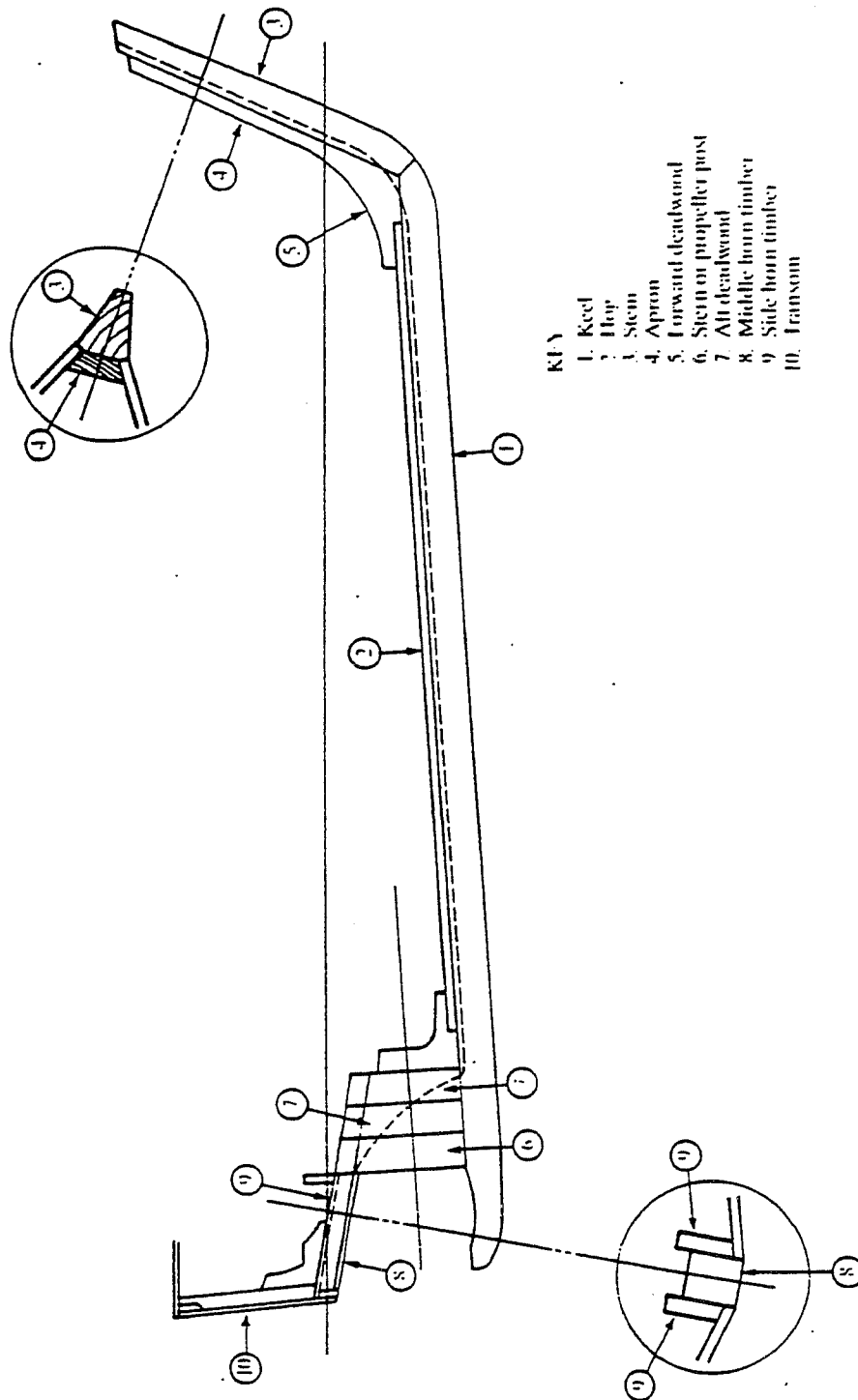

Figure M.1

PROFILE



Fig. M.2.

TYPICAL SECTION CHINE HULL

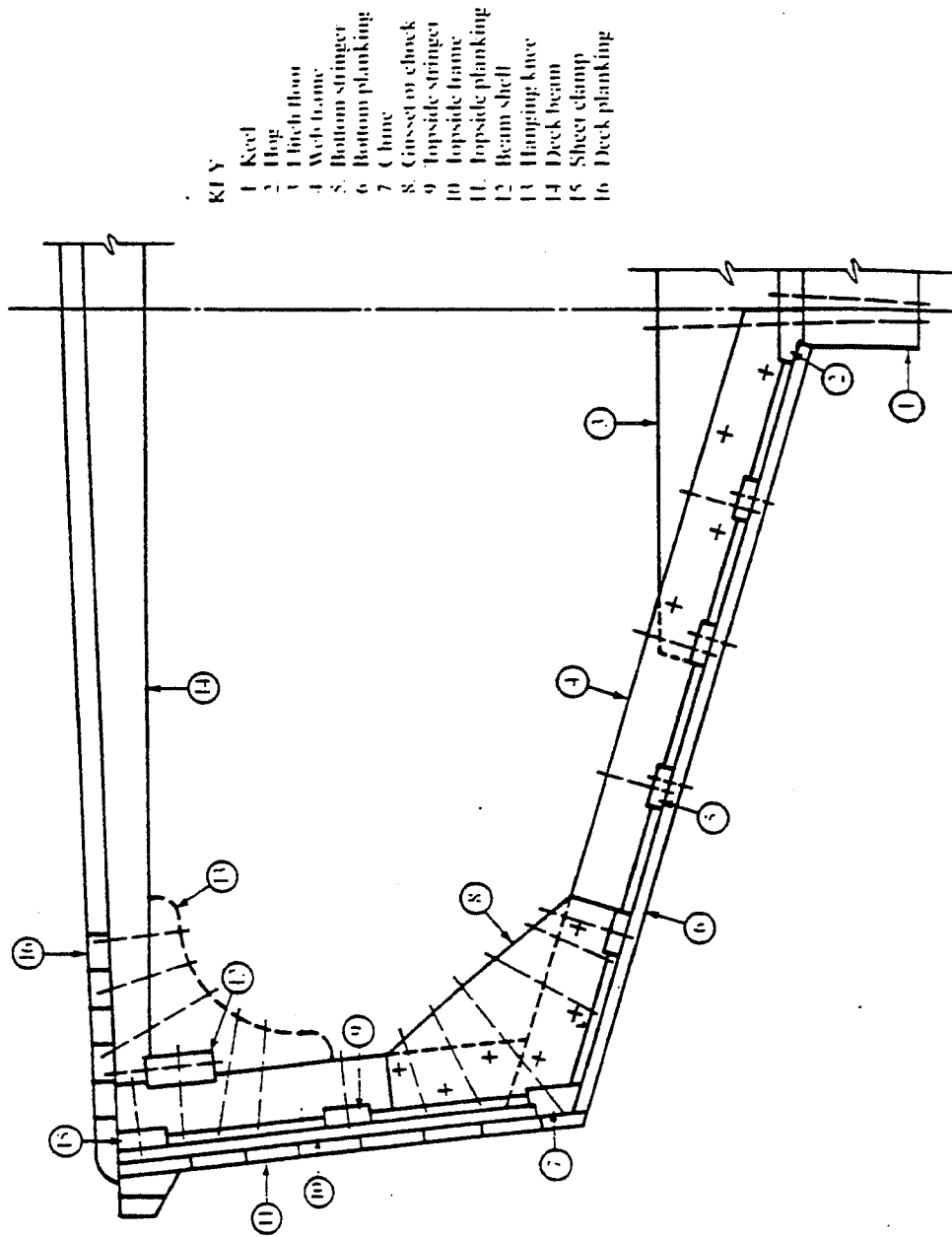

Figure M.2 TYPICAL SECTION CHINE HULL

ISOMETRIC VIEW

Fig. M.3.

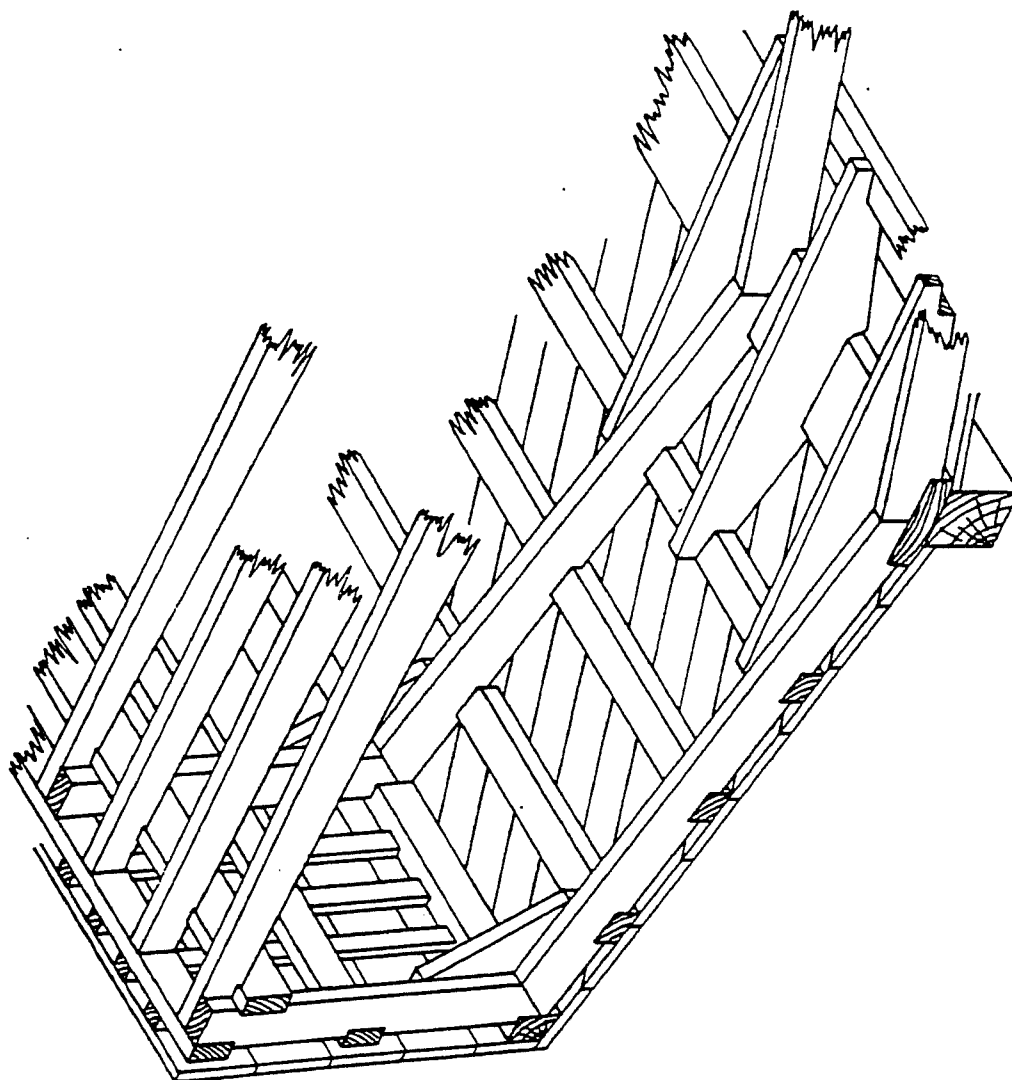

Figure M.3

ISOMETRIC VIEW

TYPICAL WEB FRAME CONSTRUCTION

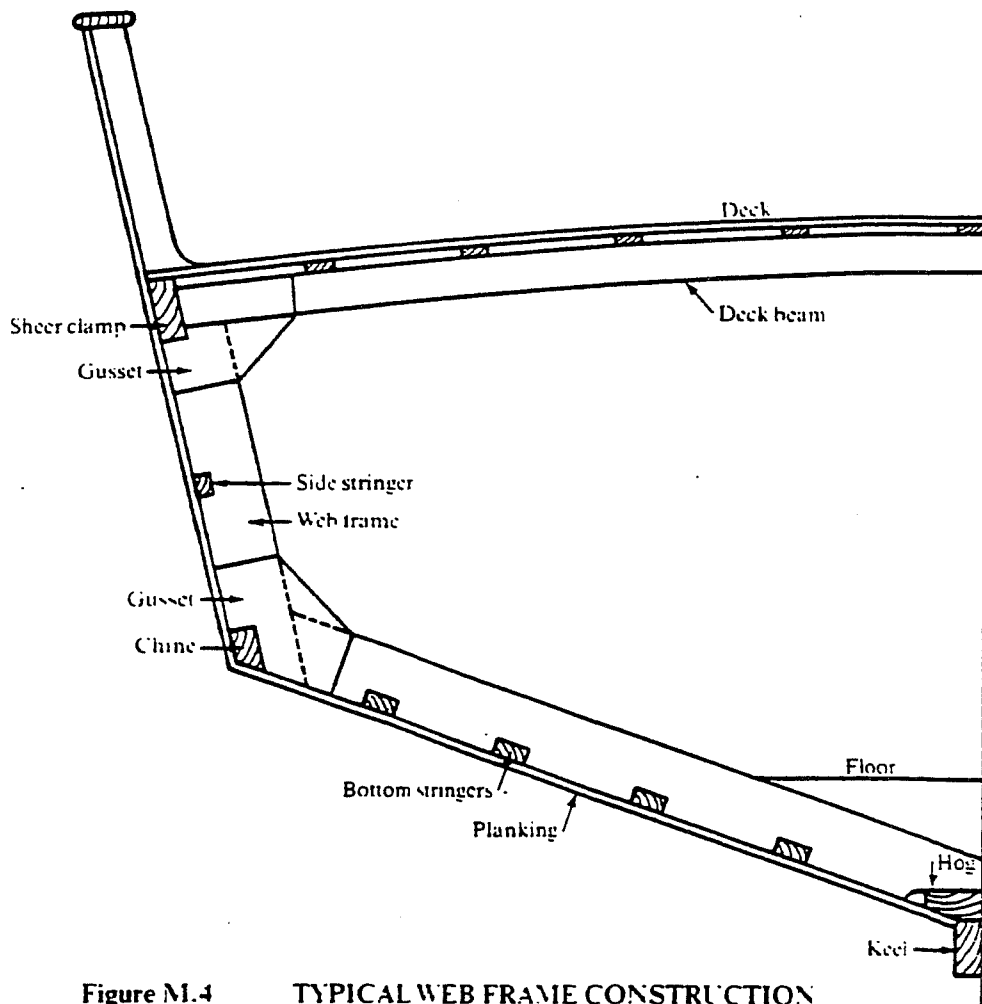
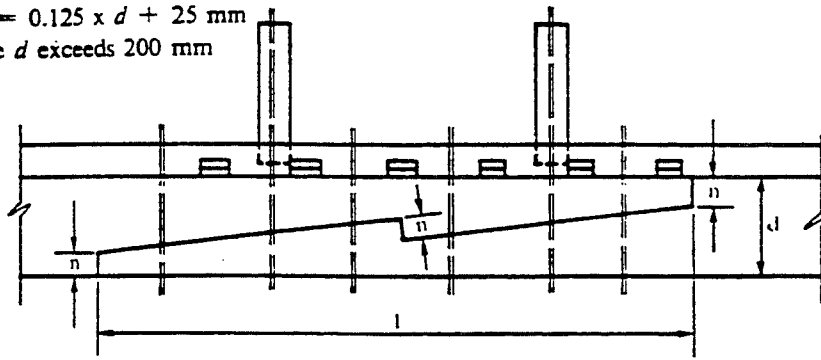
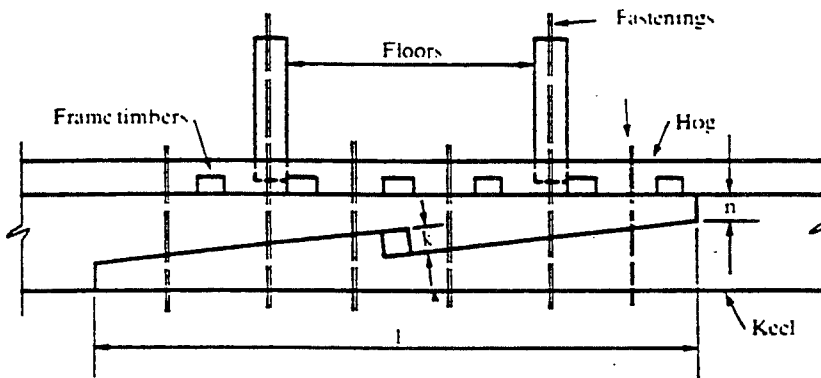

Figure M.4 TYPICAL WEB FRAME CONSTRUCTION

$l = 6 \times d$   
 $k = n$   
 $d = \text{Depth of Keel}$   
 $n = 0.25 \times d$   
 or  $n = 0.125 \times d + 25 \text{ mm}$   
 where  $d$  exceeds 200 mm



**HOOKED SCARPH**



**KEYED HOOKED SCARPH**

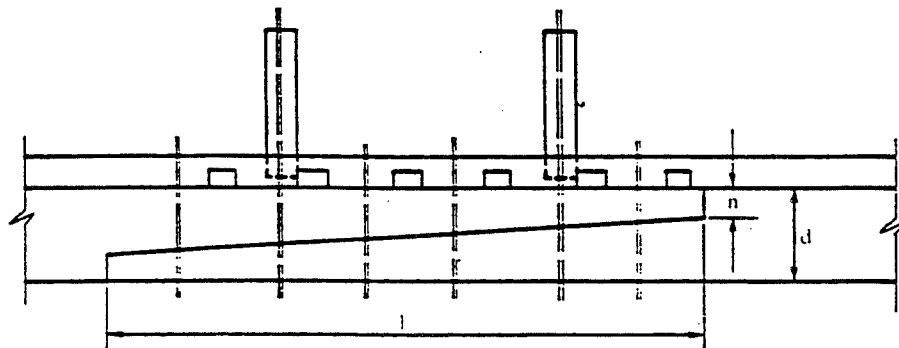

**PLAIN SCARPH**

**Figure M.5 COMMON FORMS OF SCARPHS**

TYPICAL STEM ASSEMBLY  
Fig. M.6.

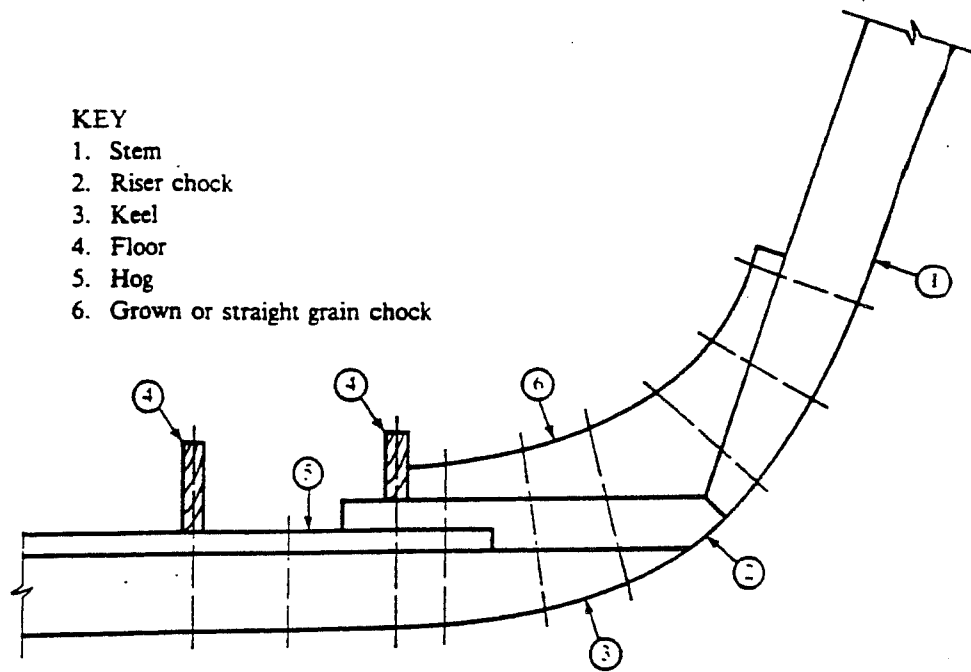

Figure M.6

TYPICAL STEM ASSEMBLY

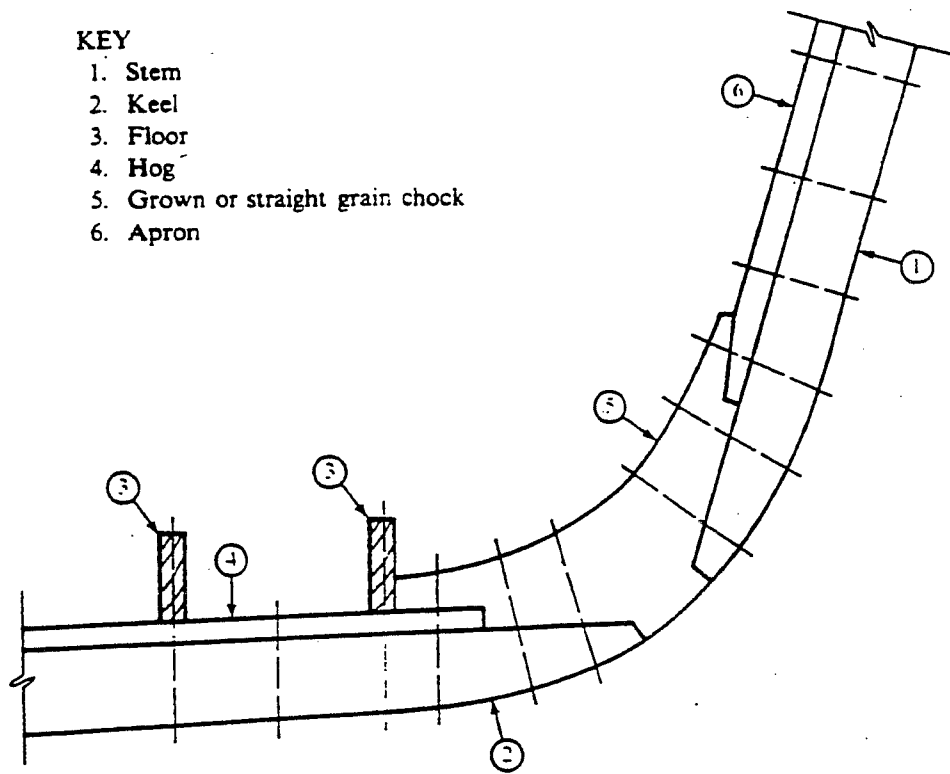
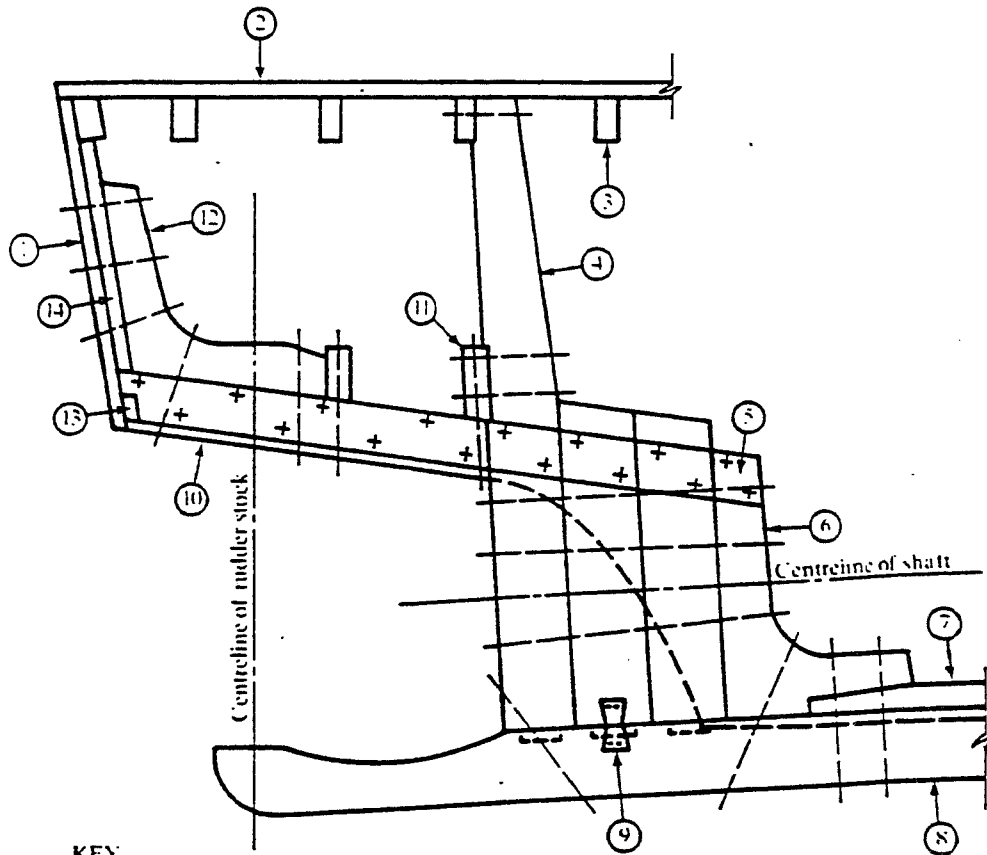

Figure M.7

ALTERNATIVE TYPICAL STEM ASSEMBLY

TYPICAL DEADWOOD AFT

Fig. M.8.



KEY

- 1. Planking
- 2. Deck planking
- 3. Deck beams
- 4. Stern or propeller post
- 5. Side horn timbers bolted to deadwood
- 6. Deadwood knee
- 7. Hog piece
- 8. Keel
- 9. Dovetail plate
- 10. Outside rabbet line
- 11. 'Transom Floor'
- 12. Transom knee
- 13. Transom margin
- 14. Transom stiffener

Figure M.8

TYPICAL DEADWOOD AFT

TYPICAL DEADWOOD AFT

Fig. M.9.

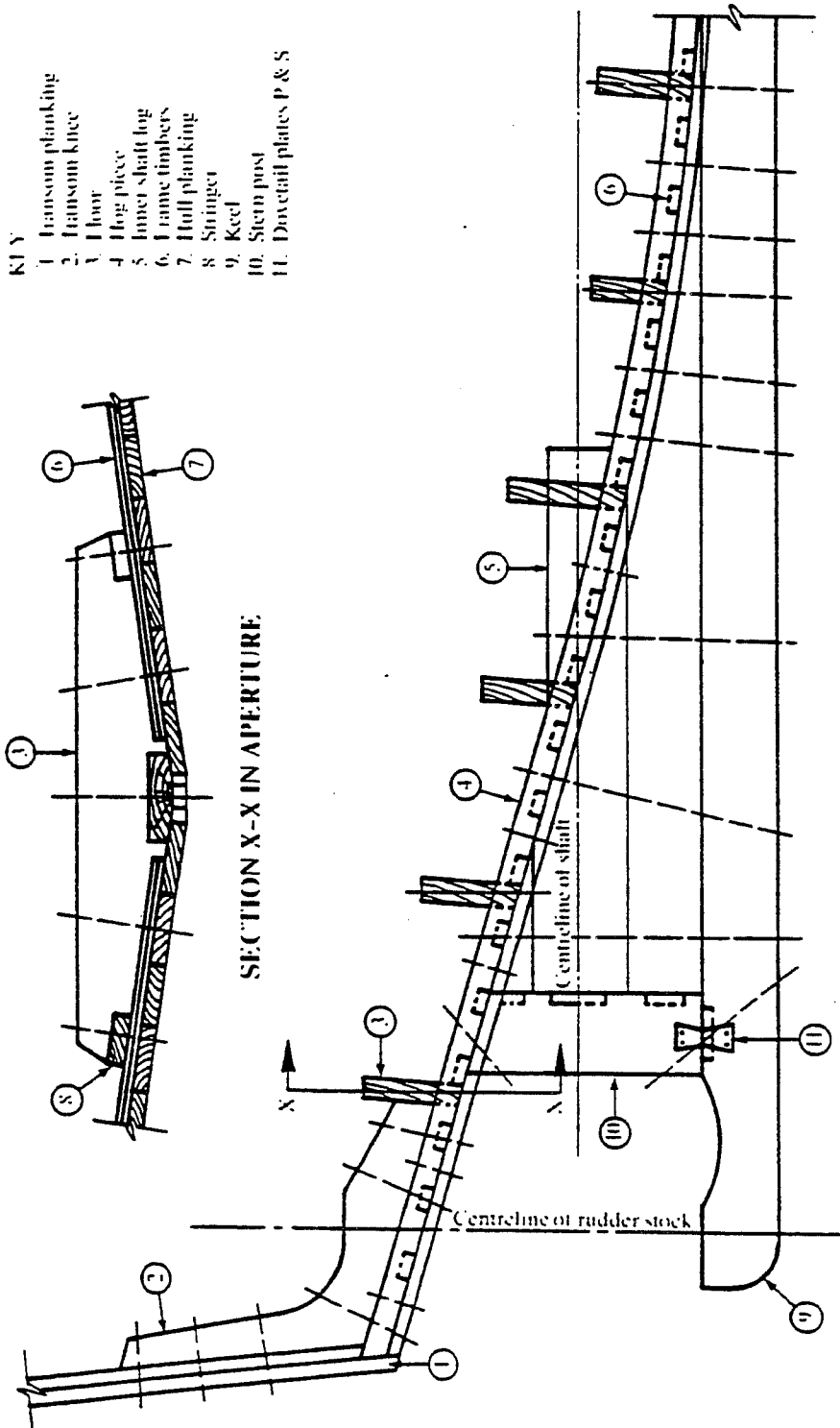

Figure M.9

TYPICAL DEADWOOD AFT



TYPICAL DEADWOOD AFT

Fig. M.10.

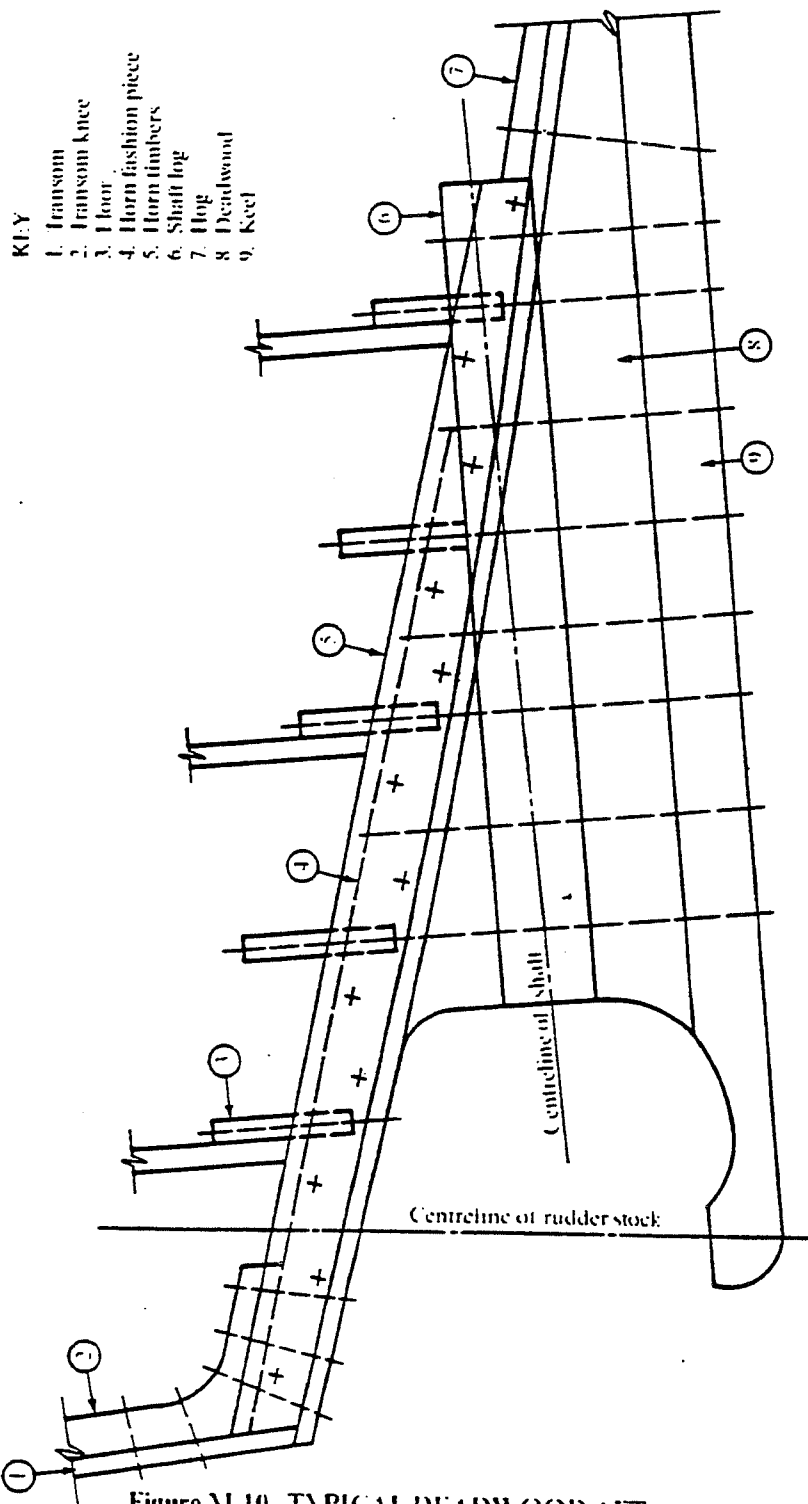

Figure M.10 TYPICAL DEADWOOD AFT

TYPICAL MIDSHIP SECTION  
BILGE TYPE HULL

Fig. M.11.

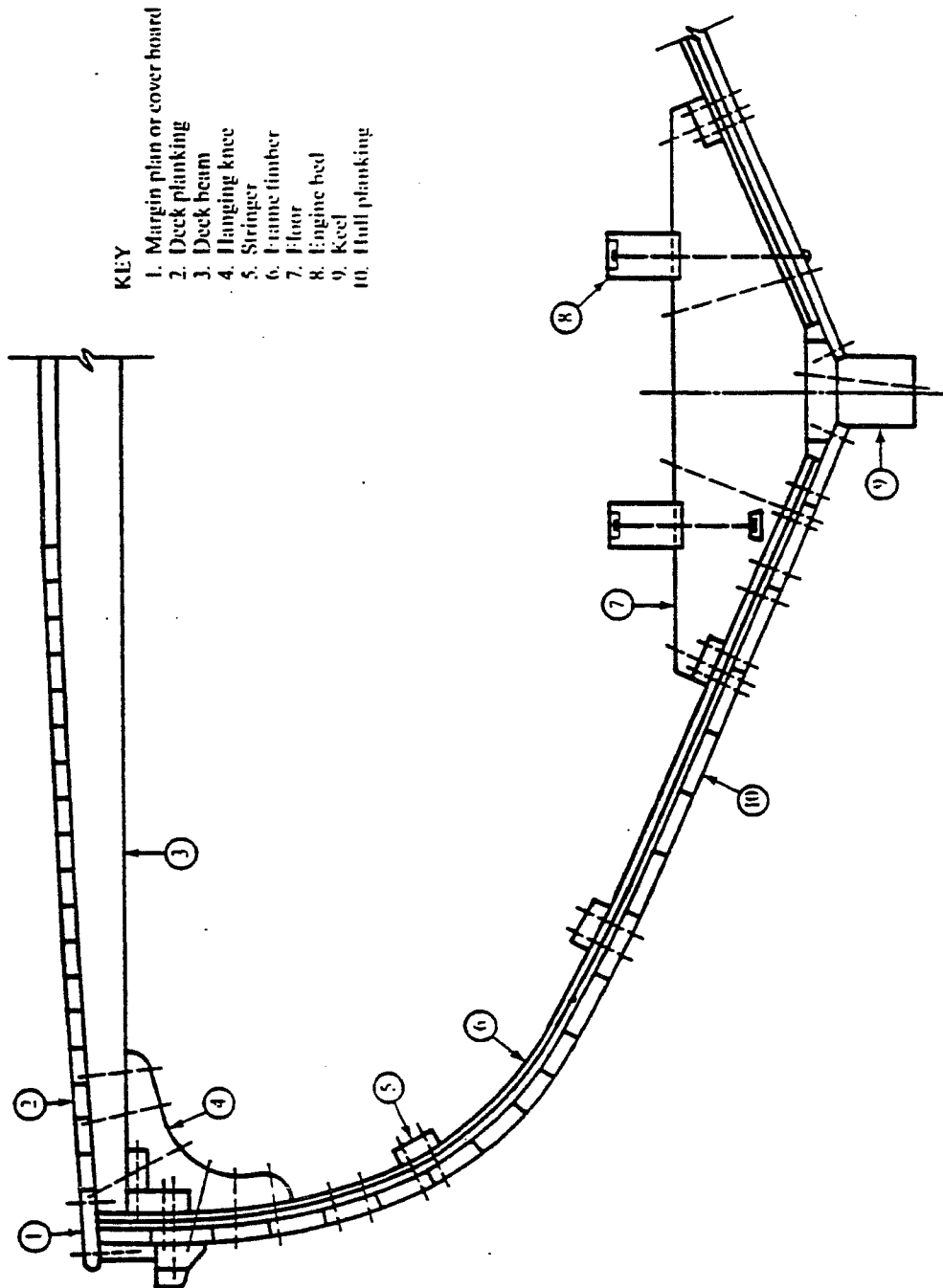
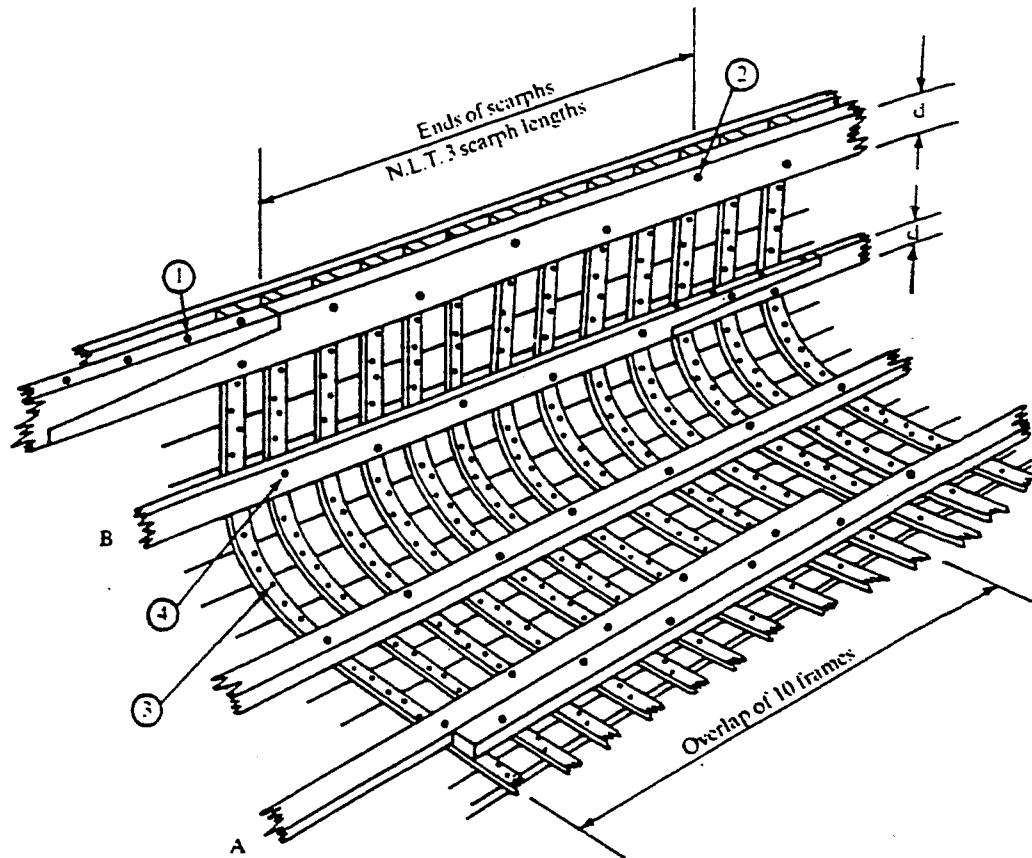

Figure M.11 TYPICAL MIDSHIP SECTION BILGE TYPE HULL

## SCARPHING AND LAPPING OF LONGITUDINALS

Fig. M.12

VIEW INSIDE HULL

*Note:*

Beam shelf, keel assembly, floors etc., are not shown.

A: Laps in stringers not less than 10 frames.

B: Scarphs not less than  $6 \times 'd'$  in length.

1. Scarphs — min. of 4 edge bolt fastenings.

2. 'Reel' or stagger fastenings.

3. Nail fastenings in frames keeled.

4. Fasten stringers and clamps thro' alternate frames.

Figure M.12

## SCARPHING AND LAPPING OF LONGITUDINALS

TYPICAL BUTT BLOCK IN HULL PLANK

Fig. M.13.

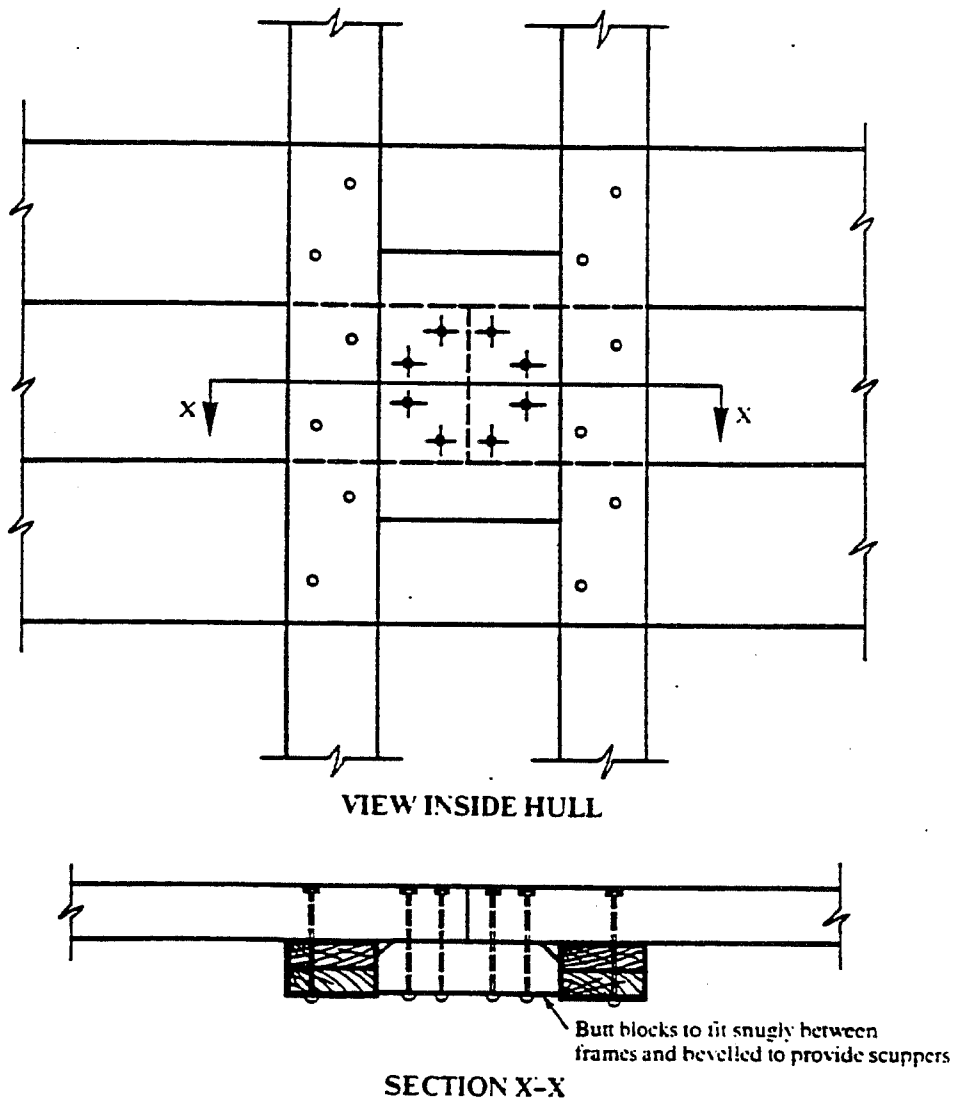

Figure M.13 TYPICAL BUTT BLOCK IN HULL PLANK