

Australian Transport Council

National Standard
for
Commercial Vessels

PART C
DESIGN AND CONSTRUCTION

SECTION 5
ENGINEERING

SUBSECTION 5A
MACHINERY

Edition 1

First Published — August 2002

Second Publication – April 2005

Draft for public comment issued — 22 December 2000

Endorsed by the Australian Transport Council — July 2002

© Commonwealth of Australia

This work is copyright. Apart from any use as permitted under the *Copyright Act 1968*, no part may be reproduced by any process without written permission of the CEO, NMSC.

Published by The National Marine Safety Committee, Level . All inquiries to be addressed to the CEO, NMSC Secretariat.

FOREWORD

This Subsection of the National Standard for Commercial Vessels (NSCV) was developed following a review of the Uniform Shipping Laws (USL) Code Section 9: Engineering, and replaces Parts 1 Preliminary, 2 General, 3 Machinery and 6 Cargo Refrigeration of that Section.

In reviewing the USL Code and preparing this Subsection, consideration was given to a number of factors, including:

- a) The National Marine Safety Strategy.
- b) Current designs, practices and materials.
- c) Relevant national and international standards.
- d) Provisions no longer used.
- e) Current survey practice, both formal and informal.
- f) Discretionary requirements which rely on Authority approval.
- g) Current technical standards format and style.

This Part of the National Standard for Commercial Vessels is intended to be read in conjunction with Part A—Safety Obligations and Part B—General Requirements.

This Subsection of the NSCV was drafted by the NMSC Secretariat in consultation with an industry reference group and a working group comprising representatives from the various State and Territory marine authorities, and the Australian Maritime Safety Authority (AMSA).

The draft Subsection was released for public comment on 22 December 2000, along with a draft Regulatory Impact Statement (RIS). Public comments were received until the end of April 2001. A reference group comprising industry and government met in May 2001 to review the public comment and provide recommendations to the NMSC. The NMSC accepted the recommendations of the working group on 30 May 2001 and the draft Subsection and RIS were revised accordingly.

The Office of Regulation Review provided an assessment of the final RIS in February 2002. NMSC approved this version of the Subsection February 2002, with the Australian Transport Council (ATC) endorsing the document for publication in July 2002.

This standard was first published in August 2002 on CD, and again in April 2005 on CD. There were no amendments between the first and second publication.

CONTENTS

CHAPTER 1	PRELIMINARY	8
	1.1 Scope	8
	1.2 Application	8
	1.3 Referenced documents	9
	1.4 Definitions.....	10
	1.5 Abbreviations.....	10
	Required outcomes	11
	1.6 Operation and maintenance	11
	1.7 Protection of persons.....	11
	Deemed-to-satisfy solutions.....	11
	1.8 Compliance.....	11
	1.9 Corrosion and abnormal loadings.....	11
	1.10 Access	11
	1.11 Identification of machinery controls and equipment	11
	1.12 Valve operation.....	12
	1.13 Manufacturer's instructions and recommendations	12
	1.14 Communication.....	12
	1.15 Guarding of machinery	12
CHAPTER 2	INTERNAL COMBUSTION ENGINES	13
	2.1 Scope	13
	2.2 Objective.....	13
	2.3 Application	13
	Required outcomes	13
	2.4 Reliability	13
	2.5 Risk of fire to be controlled	13
	2.6 Securing of machinery	13
	2.7 Propulsive control	14
	2.8 Engine monitoring.....	14
	2.9 Starting arrangements	14
	2.10 Engine exhausts	14
	2.11 Combustion air	14
	2.12 Dissipation of heat	14
	Deemed-to-satisfy solutions.....	14
	2.13 Compliance.....	14
	2.14 General.....	14

2.15	Machinery seatings.....	16
2.16	Engine monitoring.....	17
2.17	Starting arrangements	17
2.18	Unfired pressure vessels	18
2.19	Exhaust systems	18
2.20	Engine cooling systems.....	24
2.21	Ventilation of machinery spaces.....	25
CHAPTER 3	PROPULSION SYSTEMS.....	27
3.1	Scope	27
3.2	Objective.....	27
	Required outcomes	27
3.3	Reliability	27
3.4	Strength of propulsion system components	27
3.5	Vibrations.....	27
3.6	Watertight integrity.....	28
3.7	Stern drives, azimuthing propellers, water jets and other proprietary propulsion devices.....	28
	Deemed-to-satisfy solutions.....	28
3.8	Compliance.....	28
3.9	Gearboxes	28
3.10	Propeller and intermediate shafting.....	28
3.11	Keys and keyways.....	33
3.12	Propeller and shaft couplings	36
3.13	Stern bearings	40
3.14	Stern tubes and stern glands or seals	41
3.15	Propeller shaft brackets.....	42
3.16	Fixed nozzles.....	47
3.17	Stern drives, azimuthing propellers, water jets and other proprietary propulsion devices.....	47
CHAPTER 4	FUEL SYSTEMS	49
4.1	Scope	49
4.2	Objective.....	49
	Required outcomes	49
4.3	Containment of fuel	49
4.4	Minimising the risk of ignition.....	49
4.5	Minimising the risk of explosion.....	49
	Deemed-to-satisfy solutions.....	49
4.6	Compliance.....	49

4.7	Fuel tanks	49
4.8	Safety arrangements for power-operated fuel pumps and motors .	58
4.9	Additional requirements for fuel systems in vessels with non-portable fuel tanks and which operate on fuel with flashpoint more than 60°C.....	59
4.10	Additional requirements for fuel systems in vessels with non-portable fuel tanks and which operate on fuel with flashpoint less than 60°C.....	61
CHAPTER 5	FLUID SYSTEMS	66
5.1	Scope	66
5.2	Objective.....	66
	Required outcomes	66
5.3	Means for monitoring liquid levels	66
5.4	Watertight integrity.....	66
5.5	Draining of spaces within the vessel	66
5.6	Reliability	67
	Deemed-to-satisfy solutions.....	67
5.7	DischargeS inlets and seawater piping	67
5.8	Bilge pumping systems.....	70
CHAPTER 6	STEERING SYSTEMS	77
6.1	Scope	77
6.2	Objective.....	77
	Required outcomes	77
6.3	Directional control.....	77
6.4	Strength	77
6.5	Corrosion and erosion	77
	Deemed-to-satisfy solutions.....	78
6.6	Compliance.....	78
6.7	General steering design criteria.....	78
6.8	Rudder stocks.....	79
6.9	Rudders	94
6.10	Steering nozzles	99
6.11	Tiller arm or quadrant	103
CHAPTER 7	ANCILLARY SYSTEMS	105
7.1	Scope	105
7.2	Objective.....	105
	Required outcomes	105
7.3	Containment of pressure	105

7.4	Control the risk of fire	105
7.5	Reliability	105
7.6	Minimise toxicity and pollution	105
7.7	Protection from extremes of temperature	106
	Deemed-to-satisfy solutions	106
7.8	Compressed air systems	106
7.9	Hydraulic power systems.....	107
7.10	Refrigeration	107

CHAPTER 1 PRELIMINARY

1.1 SCOPE

This Subsection of the NSCV specifies requirements for the design, construction and installation of machinery in vessels.

It shall be read in conjunction with Part B—General Requirements of the NSCV.

1.2 APPLICATION

1.2.1 Vessels of measured length 35 m or more

The machinery installation on vessels of measured length 35 m or more shall—

- a) meet the requirements of, and be assessed under, the rules of a Classification Society; and
- b) comply with the requirements of Clauses 1.6 to 1.15 of this Subsection.

In addition, the following vessels of measured length 35 m or more shall also comply with the following:

- i) If Class 1A—comply with the requirements of Marine Orders Part 12.
- ii) if Class 2A of 500 GT and over—comply with the requirements of Marine Orders Part 12.
- iii) if Class 3A—comply with the requirements of the International Convention for the Safety of Fishing Vessels.

1.2.2 Vessels of measured length less than 35 m

The machinery installation on all vessels of measured length less than 35 m shall comply with the requirements of Chapter 1, Chapter 3, Chapter 4, Chapter 5, Chapter 6 and Chapter 7 of this Subsection of the NSCV.

In addition, the following vessels of measured length of less than 35 m shall comply with the following:

- a) if fitted with reciprocating internal combustion machinery—comply with the requirements of Chapter 2;
- b) if fitted with machinery other than reciprocating internal combustion machinery—meet the requirements of the rules of a Classification Society or a recognised applicable national or international standard; and
- c) if Class 1A—comply with the requirements of Marine Orders Part 12.

1.2.3 Exceptions

Vessels specifically included in Part F of this National Standard are not subject to the requirements of this Subsection, except as might be provided for in the relevant Section of Part F of the NSCV.

NOTE: Such vessels include fast craft, hire and drive vessels and novel vessels.

1.2.4 Required outcomes

The Chapters in this Subsection specify required outcomes for various machinery systems and subsystems within a vessel. The required outcomes are mandatory to the extent that they are applicable to a vessel. The required outcomes within each Chapter are followed by solutions that are “Deemed to Satisfy” these required outcomes. Compliance with required outcomes may also be achieved through the application of the equivalent solutions that comply with the principles set out in Part B of this National Standard.

When developing an equivalent solution, it is a requirement of this National Standard that the overall system safety shall be maintained.

NOTE: A proposed solution that satisfies one or more required outcomes in isolation but has negative effects on compliance with other required outcomes would not be considered an equivalent solution under Part B.

1.3 REFERENCED DOCUMENTS

The following documents are referred to in this Subsection of the NSCV. Any documents referenced in this Subsection shall be considered to be the latest revision of the document, including amendments and supplements.

AUSTRALIAN TRANSPORT COUNCIL

National Standard for Commercial Vessels

Part B—General Requirements

Part C—Design and Construction

Section 2: Watertight and Weathertight Integrity

Subsection 2A—Watertight and Weathertight Integrity—
Load Line Vessels

Subsection 2B—Watertight and Weathertight Integrity—
Non Load Line Vessels

Section 3: Construction

Section 4: Fire Safety

Section 5: Engineering

Subsection 5B—Electrical

Subsection 5D—LPG Systems for Engines

Section 6: Stability

Section 7: Equipment

Subsection 7A—Safety Equipment

STANDARDS AUSTRALIA

AS 1210—*Pressure vessels*

AS 1345—*Identification of the contents of pipes, conduits and ducts*

AS 1799.3—*Small Pleasure Boats Code – Engineering.*

AS 2906—*Fuel containers – Portable – plastics and metal*

AS 3518.1—*Acrylonitrile butadiene styrene (ABS) pipes and fittings for pressure applications – Pipes*

AS 3518.2—*Acrylonitrile butadiene styrene (ABS) pipes and fittings for pressure applications – Solvent cement fittings*

AS 3570—*Automotive diesel fuel*

AS 3791—*Hydraulic hose*

AS 4024.1—*Safeguarding of machinery – General principles*

AS 4041—*Pressure piping*

AS 4132.1—*Boat and ship design and construction – Design loadings*

AS 4132.3—*Boat and ship design and construction – Fibre-reinforced plastics construction*

AS/NZS 1667.1—*Refrigerating systems – refrigerant classification*

AS/NZS 1667.2—*Refrigerating systems – Safety requirements for fixed applications*

AUSTRALIAN MARITIME SAFETY AUTHORITY

Marine Orders Part 12—Construction—Subdivision and Stability, Machinery and Electrical Installations

INTERNATIONAL STANDARDS ORGANIZATION

ISO 4566—*Small craft with inboard engine – Propeller shaft ends and bosses with 1:10 taper*

INTERNATIONAL MARITIME ORGANIZATION

IMO Resolution A.753(18)—*Guidelines for the application of plastic pipes on ships*

MARPOL Annex 1

AMERICAN BOAT AND YACHT COUNCIL

SAE J 30—*Fuel and oil hoses*

SAE 30R9—*Fuel Injection Hose Medium-Pressure Coupled and Uncoupled Synthetic Rubber Tube and Cover*

1.4 DEFINITIONS

For the purposes of this Subsection of the NSCV the definitions provided in Part B of the NSCV shall apply.

1.5 ABBREVIATIONS

ABS—

acrylonitrile butadiene styrene

DIN—

Deutsches Institut für Normung e.V.

FRP—

fibre-reinforced plastic

LPG—

liquid petroleum gas

UTS—

ultimate tensile strength

REQUIRED OUTCOMES**1.6 OPERATION AND MAINTENANCE**

The machinery installation and systems in a vessel must be arranged to facilitate their proper operation and maintenance.

1.7 PROTECTION OF PERSONS

The machinery installation and systems in a vessel must be arranged to protect the health and safety of persons in the immediate vicinity from moving parts, excessive heat and other hazards.

NOTE: Vessels are also required to comply with Commonwealth, State or Territory legislation pertaining to occupational health and safety and to marine pollution. Advice should be sought from the appropriate Environment Protection Authority, Work Safe Authority or Marine Authority.

DEEMED-TO-SATISFY SOLUTIONS**1.8 COMPLIANCE**

For the purpose of this National Standard, the arrangement and equipment of the machinery installation and systems shall be deemed to satisfy the Required Outcomes in Clauses 1.6 and 1.7 if they comply with Clauses 1.9 to Clause 1.15.

1.9 CORROSION AND ABNORMAL LOADINGS

The machinery installation and systems on a vessel shall be designed and constructed to withstand the stresses caused by expansion, contraction, vibration, corrosion and mechanical damage.

1.10 ACCESS

The design of a machinery space shall be such that all items of the installation that may require servicing in an emergency are accessible.

1.11 IDENTIFICATION OF MACHINERY CONTROLS AND EQUIPMENT

All controls for operating the machinery, and all measuring devices, pumping systems, valves, cocks, air pipes, sounding pipes, switches and similar shall be easily identified (e.g. by form, colour, symbol or word). Where pipes are marked by colours to indicate their purpose, the colours should be in accordance with AS 1345.

NOTE: In small vessels with few controls and minimal equipment, marking of such equipment may not be necessary if the purposes of such controls and equipment are self-evident. On larger vessels with more complex machinery and systems, appropriate markings, inscriptions and diagrams will be required.

1.12 VALVE OPERATION

All valves and cocks should be fitted with permanently attached hand-wheels or handles. The hand-wheels for valves which are closed by turning anti-clockwise shall be marked to show the direction of turning for closure.

1.13 MANUFACTURER'S INSTRUCTIONS AND RECOMMENDATIONS**1.13.1 General**

With the exception of Clause 2.16.4, where a manufacturer supplies specific instructions or recommendations relating to the installation, operation and maintenance of equipment, such instructions or recommendations should be complied with.

1.13.2 Equivalent safety to be maintained

Where the manufacturer's instructions conflict with or negate a safety provision provided for in this Subsection, measures shall be put in place to ensure that the safety of the vessel is not reduced.

1.14 COMMUNICATION

Vessels of 25 m and over in measured length having a manned machinery space or a control station for the propulsion machinery outside the wheelhouse shall incorporate a means of verbal communication between the wheelhouse and the machinery space or control station.

1.15 GUARDING OF MACHINERY

Machinery shall be guarded to protect personnel.

NOTE: AS 4024.1 provides guidance on the guarding of machinery.

CHAPTER 2 INTERNAL COMBUSTION ENGINES

2.1 SCOPE

This Chapter sets out the requirements for internal combustion engines used for propulsion or for auxiliary purposes.

NOTE: For other types of engines (e.g. gas turbines or steam engines) refer to Clause 1.2.2

2.2 OBJECTIVE

The objective of this Chapter is to control risks arising from an internal combustion engine installation or a failure of that installation.

NOTES:

1. Hazards associated with internal combustion engine installations or a failure of those installations include: breakdown, failure of control mechanisms, failure to restart, fuel spillage, accumulation of explosive mixtures, loss of watertight integrity, excessive noise.
2. Consequences of these hazards include the following: loss of propulsion, loss of control in critical situations, inability to return to a safe haven, fire, environmental damage, foundering of the vessel, personal injury and death.

2.3 APPLICATION

2.3.1 Main engines

Within this Chapter, Clauses 2.4 to 2.21 shall apply to main engine installations.

2.3.2 Auxiliary engines

Within this Chapter, Clauses 2.4 to 2.6, 2.8, 2.10 to 2.12, 2.14.2, 2.14.3, 2.15, 2.16, and 2.18 to 2.21, as appropriate, shall apply to auxiliary engine installations.

REQUIRED OUTCOMES

2.4 RELIABILITY

Internal combustion engines on a vessel must be designed, constructed and arranged to provide a level of reliability appropriate for their intended purpose.

2.5 RISK OF FIRE TO BE CONTROLLED

Internal combustion engines on a vessel must be designed, constructed and arranged to control the risk of fire or explosion associated with such installations.

2.6 SECURING OF MACHINERY

Each item of machinery must be secured to the vessel's structure to prevent injury to persons, damage to components and excessive vibration.

2.7 PROPULSIVE CONTROL

Propulsion machinery and controls must be arranged to provide and maintain control over the vessel's motion in both normal and abnormal conditions of operation.

2.8 ENGINE MONITORING

Means must be provided for monitoring the condition of all engines essential for the safe operation of the vessel.

2.9 STARTING ARRANGEMENTS

Internal combustion engines on a vessel must be designed, constructed and arranged so that the primary means of starting shall not rely on aid external to the vessel.

2.10 ENGINE EXHAUSTS

The exhaust system must be arranged and constructed to dispose of the products of combustion while—

- a) protecting the health and safety of personnel; and
- b) maintaining the watertight integrity of the vessel.

2.11 COMBUSTION AIR

Where an engine draws its combustion air from the machinery space, the machinery space must have sufficient engine combustion air to fulfil the needs of the machinery operating at maximum power within the space and without adversely depressurising the space.

2.12 DISSIPATION OF HEAT

Arrangements must be provided to carry away heat radiated from machinery in order that the temperature within the machinery space is maintained at a level that is comfortable for the crew, and to prevent machinery, equipment and structures sensitive to heat from exceeding temperature limits.

DEEMED-TO-SATISFY SOLUTIONS**2.13 COMPLIANCE**

For the purpose of this National Standard, an internal combustion engine installation in a vessel shall be deemed to satisfy the Required Outcomes in Clauses 2.4 to 2.12 if they comply with Clauses 2.14 to 2.21 as applicable.

2.14 GENERAL**2.14.1 Design and manufacture**

Main engines shall either be, designed and manufactured specifically for marine use, or shall be adapted for that purpose.

NOTE: Matters, which should be considered when determining whether an engine is suited for adaptation for marine use, include the following:

- a) The means for distributing axial thrust transmitted by shafting into the vessel's structure (most engines are not designed to withstand axial thrust).
- b) The arrangement of the sump and lube oil system to cope with the mounting of the engine at an angle from the horizontal (due the shaft angle or trim) and the rolling, pitching and other motions of the vessel when operating at sea.
- c) The arrangement of the engine cooling system and the suitability of the engine materials to the marine environment.
- d) The provision of a gearbox suitable for marine use, and the incorporation of power take-offs (PTOs) that might be required.
- e) The provision of a two-wire system for electrical components including starter motors, generators, instrumentation pick-ups and alarms.

2.14.2 Fuel

Unless otherwise permitted by Clause 2.14.3, engines shall operate on fuel having a closed flashpoint of not less than 60°C.

2.14.3 Vessels where fuel having a flashpoint less than 60°C is permitted

Fuel having a flashpoint less than 60°C may be used in the following applications:

- a) Outboard engines in Class C, D and E vessels.
- b) Internal combustion engines in Classes 2C, 2D, 2E, 3C, 3D and 3E vessels that are not located below decks.

NOTE: An engine is considered to be "below decks" if fuel or fumes emanating from the engine installation could result in the accumulation of fuel or explosive mixtures within any space on the vessel. Fuel or fumes from the engine must be able to drain rapidly and directly overboard without the assistance of forced ventilation or wind-induced air movement.

2.14.4 Outboard engines

2.14.4.1 General requirements for seagoing vessels

Seagoing vessels powered by outboard engines shall have at least two such engines, with the exception of—

- a) vessels provided for in Clause 2.14.4.3; and
- b) Class C vessels where the outboard engine operates on fuel having a flashpoint of 60°C or more, in which case a single outboard engine may be used.

2.14.4.2 Requirements for second outboard engine

Each of the two engines specified in Clause 2.14.4.1 shall be capable of maintaining sufficient speed and directional control to bring the vessel to a safe haven in all weather conditions likely to be encountered.

NOTE: The outboard engines need not be of equal power.

2.14.4.3 Single outboard engines

Single outboard engines may be fitted on Class 2 and Class 3 vessels subject to the following conditions:

- a) Geographical restrictions of 5 nautical miles to sea and 30 nautical miles laterally along the coast from a designated sheltered water or a safe haven are observed.

NOTE: Part B defines a safe haven.

- b) The vessel is provided with an alternative means of emergency propulsion, and rescue services are readily available.
- c) The vessel does not carry passengers.

NOTES:

1. Individual Authorities may permit vessels fitted with single outboard engines to operate outside the limits specified in (a) to (c) above as an equivalent local solution. Details of legislation or policy pertaining to the operation of vessels fitted with single outboard engines should be sought from the applicable Authority.
2. When compared to a single inboard diesel engine, a single outboard engine could be less suitable for operations outside sheltered waters due to the increased likelihood of breakdown and the difficulty in carrying out running repairs at sea.

2.14.5 Astern power

Where the shaft power available for propulsion exceeds 5 kW, a vessel shall have sufficient astern power to enable manoeuvrability under normal operating conditions.

2.14.6 Remote shutdown of main propulsion engines

Where a main propulsion engine is located in an enclosure that is not readily accessible from a permanently manned control station, manual mechanical means shall be provided to enable the engine to be quickly shut down from a location outside the engine space. On vessels of 25 m and over in measured length, the manual remote shutdown shall be located at a control station. The remote shutdown shall be capable of operating when exposed to flame and heat from a fire within the engine enclosure.

NOTES:

1. Fail-safe arrangements may not be suitable where an electrical or other fault could cause an uncontrolled shutdown of the propulsion machinery.
2. Some proprietary cables for remote operation of equipment fail when exposed to high temperatures or flame. Cables and their casings or open cables and their pulley systems should be fire-resistant.

2.15 MACHINERY SEATINGS**2.15.1 Attachment**

Each item of machinery shall be bolted securely to a rigid seating. Nuts and bolts shall incorporate means to prevent them backing off.

NOTE: Secure bolting is not limited to rigid bolting. Machinery may be bolted to the machinery seating via a resilient mount (refer to Clause 2.15.3).

2.15.2 Wood and fibre-reinforced plastic (FRP)

Where machinery seatings are made of wood or FRP, the seatings shall be of sufficient thickness to ensure ample material in compression when bolts are tightened.

2.15.3 Flexible couplings

The output shaft shall be connected to a flexible coupling where—

- a) resilient mountings are fitted; and

- b) the distance from the gearbox coupling to the first bearing is less than 20 times the actual shaft diameter.

2.15.4 Propeller thrust

Means to facilitate the transfer of thrust from the propeller and shaft to the vessel structure shall be incorporated.

2.16 ENGINE MONITORING

2.16.1 General

Instruments shall be—

- a) suitable for marine use;
- b) capable of withstanding vibration and shock;
- c) installed to be readily visible; and
- d) illuminated if required to be read or operated in darkness.

2.16.2 Essential monitoring

All engines essential for the safe operation of the vessel shall be fitted with instrumentation to enable critical engine parameters to be monitored from a continuously manned control station. On vessels with an unmanned machinery space, the instrumentation shall be located adjacent to the steering position. Subject to the requirements of the engine manufacturer, the following instrumentation should be provided:

- a) Engine lubricating oil pressure.
- b) Engine jacket cooling water outlet temperature.
- c) Engine gearbox lubricating oil pressure.
- d) Charging rate of generator or state of battery charge.
- e) Rotational speed (in the case of propulsion machinery).

NOTE: In addition to the above instrumentation, Clause 6.7.7 requires a rudder position indicator for certain vessels.

2.16.3 Engine alarms

All engines essential for the safe operation of the vessel shall be fitted with sufficient audible or visible alarms to indicate abnormal conditions to a crew member at a continuously manned control station.

2.16.4 Automatic shutdown of propulsion machinery not permitted

Propulsion machinery shall not be fitted with automatic shutdown devices, notwithstanding that the manufacturer may specify and supply such devices.

2.17 STARTING ARRANGEMENTS

2.17.1 Primary means of starting

The primary means of starting shall not rely on aid external to the vessel. Air receivers or batteries used for starting main engines shall have sufficient capacity without recharging to provide—

- a) Six (6) consecutive starts for each non-reversible engine; and
- b) Twelve (12) consecutive starts for each reversible engine.

NOTE: For details on battery installation, venting and switch gear, refer to Part C Subsection 5B (Electrical) of the NSCV.

2.17.2 Hand cranks

Where hand cranks are used to start engines, they shall be designed to facilitate rapid withdrawal. Hand cranks shall be designed to disengage instantly when the engine starts.

All machinery incorporating a hand-starting facility shall be located to provide sufficient space for hand-starting operations to be carried out.

2.17.3 Air-starting arrangements

Air-starting arrangements shall comply with Marine Orders Part 12 or the requirements of a Classification Society.

2.17.4 Alternative starting arrangements

Where main engines in Class A, B, C or D vessels are not fitted with hand-starting arrangements, a second method of starting the engines shall be provided. The second means of starting shall not rely on aid external to the vessel.

Where a hydraulic accumulator is used, then the accumulator shall be capable of being pressurised manually.

NOTE: Where an engine is started electrically, a stand-by battery or bank of batteries would be considered to satisfy the requirement for a second means of starting.

2.18 UNFIRED PRESSURE VESSELS

Unfired pressure vessels and their mountings shall be designed, constructed and tested in accordance with AS 1210, or the requirements of a Classification Society.

2.19 EXHAUST SYSTEMS

2.19.1 Protection of personnel from fumes

Exhaust gas shall not leak from the piping or any connections. An exhaust pipe that passes through an accommodation space shall be enclosed in a gas-tight trunk.

2.19.2 Location of discharge

Exhaust gases shall be discharged to the atmosphere clear of ventilators and other openings so as to minimise the possibility of exhaust gases passing back into the vessel.

2.19.3 Separation of exhaust pipes

Exhaust pipes of several engines shall not be connected together, but shall run separately to the atmosphere to prevent any possibility of the exhaust gases returning to an idle engine.

2.19.4 Material

Exhaust pipes and silencers shall be constructed of material resistant to heat and exhaust products and suited to the application. Where exhaust pipes come into contact with seawater or sea spray, they shall also be of corrosion-resistant material or heavy-gauge construction.

Reinforced rubber hose may be used for exhaust pipes on engines having water-cooled exhausts, except where the exhaust is required to be enclosed in gas-tight trunking under Clause 2.19.1 above. Reinforced rubber hose shall be secured at each end by at least two corrosion-resistant clips.

NOTE: Only certain grades of stainless steel are suitable for use in exhaust systems. Examples of suitable stainless steels are UNS S31254 and DIN 2.4856.

2.19.5 Layout and support

All of the exhaust system shall be arranged so as to be readily visible for inspection, except for those sections required to be enclosed in gas-tight trunking, enclosed by a water jacket, or lagged with insulating material. Exhaust pipes shall be adequately supported and the number of bends and elbows minimised.

2.19.6 Silencer

All internal combustion engines shall be silenced to comply with applicable legislation. Figure 1 provides a typical layout of a dry exhaust system, which incorporates a silencer.

NOTE: State and Territory Occupational Health and Safety authorities and Environment Protection Authorities can advise on legislation covering permissible noise levels.

2.19.7 Cross-sectional area of exhaust pipes

No part of an exhaust pipe shall have a cross-sectional area less than that of the outlet of the exhaust manifold, unless otherwise specified by the engine manufacturer.

NOTE: Exhaust systems should be arranged and sized so as to prevent back-pressures higher than acceptable to the engine manufacturer. This may necessitate an increase in the cross-sectional area of the pipe above that at the outlet of the exhaust manifold if the exhaust system is very long or contains numerous bends.

2.19.8 Thermal protection

Exhaust piping and silencers shall be water-cooled, shielded or insulated. The exhaust system shall be installed to prevent any possibility of the transfer of heat from any part of the system to adjacent combustible materials. It shall be arranged and guarded as necessary to prevent personnel from accidentally coming into contact with hot surfaces.

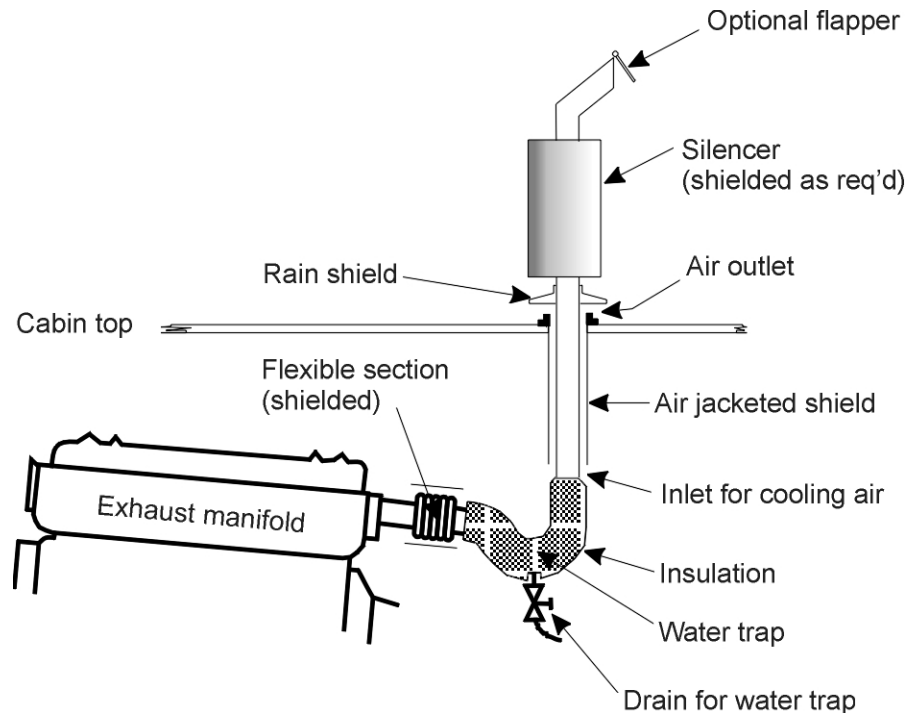

Figure 1 — Typical dry exhaust system

2.19.9 Through-hull exhaust discharges

Exhaust pipes that discharge through the hull of a vessel should be water-cooled. Typical water-cooled exhaust installations are illustrated in Figure 2, Figure 3, and Figure 4. Exhaust pipe discharges should be installed as high as practicable above the deepest loaded waterline to reduce the potential for ingestion of water into the exhaust system through wave or wake action, both when the engine is operational or idle.

2.19.9.1 Dry exhaust discharges

If a dry exhaust is fitted that penetrates the hull, the discharge shall be installed so as to limit the transfer of heat into the hull structure.

NOTE: In addition to the potential fire hazard, prolonged exposure to heat may degrade the hull material.

2.19.9.2 Water-cooled (wet) exhausts

The design of a water-cooled exhaust system shall also be such that—

- a) water injected into the exhaust cannot enter the engine (refer to dimension 'a' in Figure 2, Figure 3, and Figure 4); and
- b) arrangements are in place to reduce back pressure.

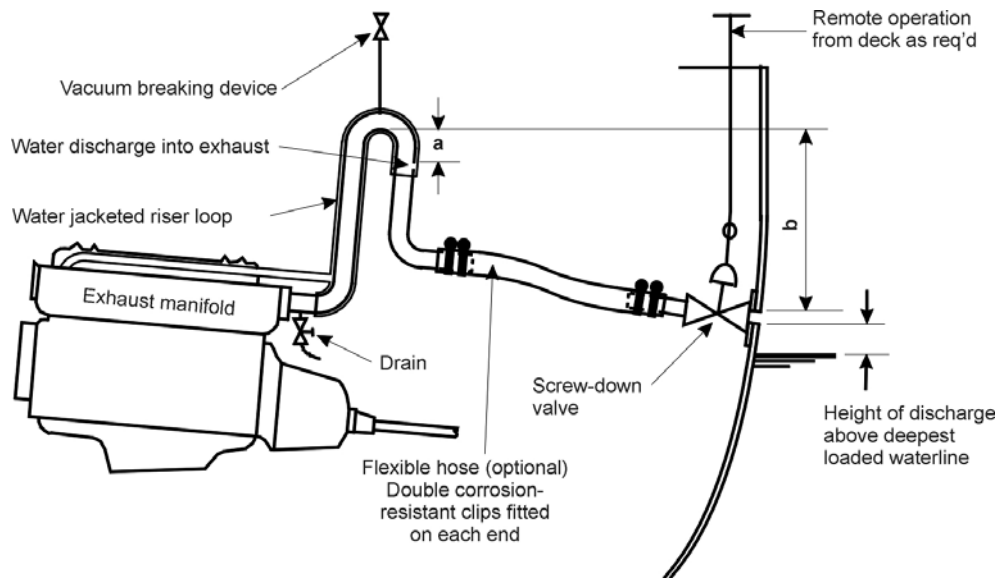

Figure 2 — Typical water-cooled exhaust incorporating a water jacketed riser loop and shut-off valve at the discharge

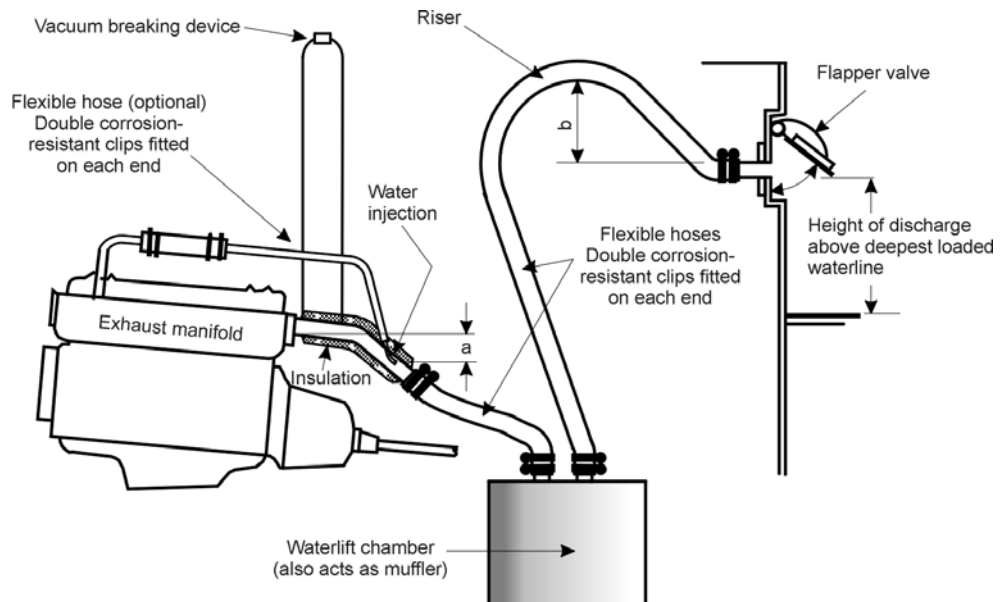

Figure 3 — Typical water-cooled exhaust incorporating a waterlift chamber, riser and flapper valve at the discharge

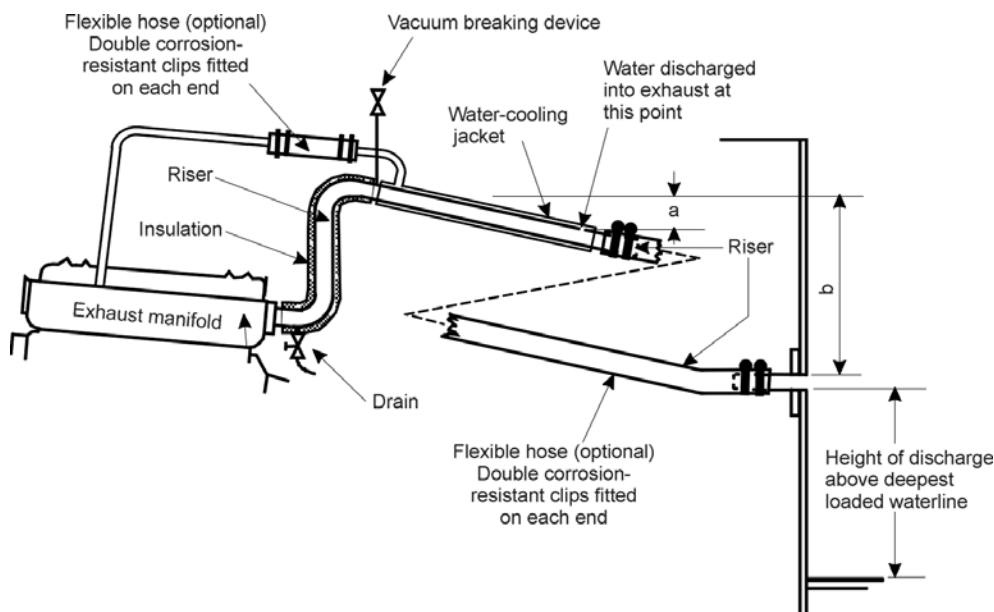

Figure 4 — Typical water-cooled exhaust incorporating a water cooling jacket, riser and no valve at the discharge

2.19.9.3 Arrangements to prevent back-flooding of machinery

Exhaust pipes that discharge below the freeboard deck shall incorporate a riser or other device to prevent water returning to the engine (refer to distance “b” in Figure 2, Figure 3, and Figure 4). Where the exhaust arrangement is such as to promote the accumulation of water between the engine and a riser or loop, then a drain cock or valve shall be fitted near the exhaust manifold to permit periodic drainage. A vacuum-breaking device shall be fitted to the top of risers where there is a risk of water being drawn into the engine as the system cools.

NOTE: A riser may incorporate a steady fall from the highest point of the exhaust, to the injection point, to the discharge as Figure 4. The riser may also take the form of a loop, which acts as a dam as in Figure 2 and Figure 3. Alternatively, a loop may be introduced into the system to act as a water trap as illustrated in Figure 1. Where the loop acts as a trap, a means to release the trapped water from the loop should be fitted.

2.19.9.4 Waterlift exhaust system

A waterlift exhaust system may be used where the engine is very close to or below the deepest loaded waterline (see Figure 3).

NOTE: The waterlift exhaust system incorporates an accumulating chamber in which the cooling water collects before being expelled by exhaust gas via a riser.

Engine manufacturers should be consulted regarding any requirements they may have to avoid or limit exhaust pressures where the exhaust is discharged below water level.

2.19.9.5 Watertight integrity of exhaust pipe discharges

Exhaust pipe discharges shall be arranged such that a breach of the exhaust pipe (e.g. through corrosion or fatigue) will not result in flooding of the vessel. They shall also comply with the following:

a) *Load Line Vessels*

Exhaust pipe discharges which penetrate the shell below the level of the freeboard deck shall comply with the Load Line conditions of assignment contained in Part C Section 2A (Watertight and Weathertight Integrity - Load Line Vessels) of the NSCV.

b) *Vessels other than Load Line vessels*

Exhaust pipe discharges shall comply with the following:

- i) Discharges that penetrate the shell below the level of the weather deck, but at a height not less than 225 mm above the deepest loaded waterline, shall be fitted with a non-return valve, non-return flap or other similar arrangement as in Figure 3.
- ii) Discharges that penetrate the shell at a height less than 225 mm above the deepest loaded waterline shall be fitted with a shut-off valve as in Figure 2. If located within the machinery space, the shut-off valve may be controlled locally, provided it is fitted in an easily accessible position and, in the case of unmanned machinery spaces, a bilge level alarm is fitted. In all other cases, the shut-off valve shall be fitted with a positive means for closing the valve from a position above the weather deck

NOTE: The term "weather deck" refers to the uppermost continuous deck or bulkhead deck.

2.19.9.6 *Alternative arrangements for watertight integrity of exhaust pipe discharges*

Where on a Class B, C, D or E vessel less than 24 m in measured length it is found impracticable to meet the provisions in Clause 2.19.9.5(b), exhaust pipe arranged as provided in Table 1 shall also be deemed to satisfy the required outcome.

2.19.9.7 *Location of shut-off and non-return valves*

Where shut-off or non-return valves are required on an exhaust discharge, they shall be located on or as close to the shell as practicable. Where a section of exhaust pipe is provided between the hull and a shut-off or non-return valve, it shall have a minimum thickness 1.25 times that calculated for a hull of the same material, were the hull to be made of the same material as the section of the exhaust.

2.19.9.8 *Penetrations through watertight bulkheads*

Exhaust pipe penetrations through watertight bulkheads shall be via a watertight fitting on the bulkhead. Such penetrations should be located as high on the bulkhead as possible and inboard from the vessel sides.

Table 1 — Alternative arrangements for watertight integrity of exhaust pipe discharges

Height of discharge above the deepest loaded waterline	Requirement
Less than 75 mm	<p><u>Class 2D, 2E, 3D and 3E vessels of length less than 12.5m</u> — A non-return valve, non-return flap, one-way “flapper valve” (see Figure 1), or similar device to prevent back-flooding by waves or wash may be fitted provided a level of safety equivalent to a one-compartment standard of subdivision is achieved in the event of the compartment containing the exhaust discharge becoming flooded.</p> <p>NOTE: No “deemed to satisfy” solution is available for vessels other than Class 2D, 2E, 3D and 3E vessels of length less than 12.5m.</p>
Between 75 mm and 225 mm	<p>A non-return valve, non-return flap, one-way “flapper valve” (see Figure 3) or similar device to limit the rate of flooding by waves or wash may be fitted provided—</p> <ul style="list-style-type: none"> a) a bilge level alarm is fitted in the compartment where the exhaust pipe discharge penetrates the hull; b) that part of the exhaust system between the shell and the highest point of the loop or riser in the exhaust piping or the apparatus to prevent back-flooding of the engine is constructed of stainless steel or other material of equivalent corrosion resistance; and c) the non-return valve, non-return flap, one-way “flapper valve” or other device to limit the rate of flooding by waves or wash is resistant to corrosion due to the products of combustion and water, and to weathering.
Greater than 225 mm	<p>No non-return valve or flap may be fitted (see Figure 4) provided—</p> <ul style="list-style-type: none"> a) a bilge level alarm is fitted in the compartment where the exhaust pipe discharge penetrates the hull; b) the means provided to prevent back-flooding of the engine is capable of dealing with frequent water ingestion; and c) that part of the exhaust system between the shell and the highest point of the loop or riser in the exhaust piping or the apparatus to prevent back-flooding of the engine is constructed of stainless steel or an equivalent corrosion-resistant material

2.20 ENGINE COOLING SYSTEMS**2.20.1 Air cooling**

In air-cooled engines, the discharge from the cooling air system shall be trunked separately to the atmosphere.

2.20.2 Water cooling

In water-cooled engines, a system of keel cooling for the engine jacket water may be installed as an alternative to a water circulating system.

NOTE: The performance of keel cooling arrangements should be such as to maintain engine cooling water temperatures to within the engine manufacturer’s specifications taking into account the likely range of ambient seawater temperature and the effects of marine growth and protective coatings.

2.21 VENTILATION OF MACHINERY SPACES

2.21.1 General requirements

Each machinery space shall be fitted with a system of ventilation. All machinery space ventilators shall be fitted with closing devices to shut the space down in the event of a fire. At least one inlet duct shall extend down to the bottom of the machinery space to clear fumes from the bilge and promote the circulation of fresh air, and an air outlet shall be fitted at the top of the machinery space to remove hot air.

NOTES:

1. Ventilation arrangements provide air for engine combustion, personnel requirements and the removal of heat from the machinery space.
2. A further objective of machinery space ventilation is to maximise the performance of the machinery installation. A lower air intake temperature reduces the heat rejection to the engine coolant, thus increasing the efficiency and maximum available power.

2.21.2 Natural ventilation

If natural ventilation is employed, the total area of inlet and exhaust ventilators shall be sufficient to satisfy the requirements specified by the engine manufacturer, taking into account all main and auxiliary engines within the space. However, the total area of air inlet and exhaust ventilators shall not be less than 500 mm² and 200 mm² respectively per installed kW power of main and auxiliary engines within the space. Cowls, scoops, louvres or alternative arrangements should be fitted to the air inlet and exhaust ventilators in order to promote airflow.

The air temperature inside a machinery space should not be more than 17°C above the outside ambient air temperature. If natural ventilation alone fails to keep the temperature rise within such limits, forced ventilation should be considered so as to provide an equivalent solution.

2.21.3 Forced ventilation

Forced ventilation shall be installed if required by the engine manufacturer. Forced ventilation should also be installed in spaces containing machinery of high power, or where it is impractical to fit the area of ventilators required for natural ventilation. The size of the fan or fans for forced ventilation shall be determined by summing the requirement for air specified by the manufacturer of each engine within the space, taking into account the combustion air requirements and heat radiation of all main and auxiliary engines within the space. However, the inlet fan capacity shall not be less than the sum of combustion air required plus 50 per cent.

2.21.4 Ventilator area

Where cowls, scoops or intakes are screened, or intakes are fitted with filters, the mouth area shall be increased to compensate for the loss of clear area because of the screen wire or filter. The clear area of a cowl, scoop or louvres intended for natural ventilation should not be less than twice the required ventilator area.

2.21.5 Location

Machinery space ventilator openings shall be located to—

- a) avoid obstructions on the decks which could restrict the flow of air into or out of the ventilator;
- b) avoid the possibility of exhaust air being drawn into an inlet ventilator;
- c) avoid the ingestion of large quantities of salt spray which could damage the machinery; and
- d) comply with the relevant requirements for ventilator coaming heights contained in Part C Subsection 2A (Watertight and Weathertight Integrity—Load Line Vessels) of the NSCV, or in Part C Subsection 2B (Watertight and Weathertight Integrity—Non Load Line Vessels) of the NSCV.

NOTE: As well as being required to meet minimum coaming height requirements, engine room air vents are frequently found to be the first point of down-flooding for the purposes of the stability criteria contained in Part C Section 6 (Stability) of the NSCV. Hence, these openings should be located near the centreline and/or as high above the waterline as practicable so as not to prematurely compromise the vessel's stability.

CHAPTER 3 PROPULSION SYSTEMS

3.1 SCOPE

This Chapter specifies requirements for gearboxes; propeller shafting and shafting components; shaft bearings, brackets and seals; fixed nozzles and proprietary propulsion devices. It applies to vessels of less than 35 m in measured length.

NOTE: For vessels of 35 m or more in measured length, refer to Clause 1.2.1.

3.2 OBJECTIVE

The objective of this Chapter is to control the risks associated with a failure of the transmission system between the propulsion machinery and the propeller.

NOTES:

1. Specific hazards associated with a failure of the transmission system include the following: failure of shafting or fittings through overloading or fatigue, excessive vibration, overheating of bearings, loss of watertight integrity of the hull.
2. Consequences that may arise from a failure of the transmission system include: loss of propulsive power in critical situations, inability to return to shelter, foundering of the vessel, injury to persons.

REQUIRED OUTCOMES

3.3 RELIABILITY

Gearboxes; propeller shafting and shafting components; shaft bearings, brackets and seals; and fixed nozzles must be designed and constructed so as not to render the propulsion system unreliable.

3.4 STRENGTH OF PROPULSION SYSTEM COMPONENTS

Gearboxes and propeller shafting and shafting components must be capable of transmitting the torque generated by the prime mover under all conditions of operation for their designated service life.

Transmission components must be designed and manufactured so that they are capable of—

- a) transmitting the maximum torque of the prime mover;
- b) resisting torsional vibrations, whirling stresses, impact loads, wear and corrosion; and
- c) operating without fatigue failure over a predetermined period appropriate for the type of vessel.

3.5 VIBRATIONS

Gearboxes, propeller shafts, intermediate shafts, propeller brackets and other components of the propulsion system must be designed and constructed to prevent excessive vibrations, both in normal and abnormal conditions.

3.6 WATERTIGHT INTEGRITY

Propeller shafts, stern tubes, propeller brackets and other components of the propulsion system must be arranged to prevent the ingress of excessive quantities of seawater, both in normal and abnormal conditions.

3.7 STERN DRIVES, AZIMUTHING PROPELLERS, WATER JETS AND OTHER PROPRIETARY PROPULSION DEVICES

Stern drives, azimuthing propellers, water jets and other proprietary propulsion devices must provide a level of safety equivalent to that required in this Chapter for a conventional propulsion system.

DEEMED-TO-SATISFY SOLUTIONS

3.8 COMPLIANCE

For the purpose of this National Standard, a propulsion system in a vessel shall be deemed to satisfy the Required Outcomes in Clauses 3.3 to 3.7 if they comply with Clauses 3.9 to 3.17 as applicable.

3.9 GEARBOXES

Gearboxes shall be specifically designed or adapted for marine use and shall be matched to the prime mover with which they are to be used. When coupled to the prime mover, it shall not be possible to exceed the limiting power, torque, speed or thrust of any component of the gearbox.

3.10 PROPELLER AND INTERMEDIATE SHAFTING

3.10.1 Shaft material

Shafts shall be manufactured from material having the following minimum required mechanical properties:

- a) Ultimate tensile strength (UTS)—410 MPa
- b) Yield point—230 MPa
- c) Elongation—Bronze: 25%, Carbon Steel: 23%, Monel: 20%, Stainless Steel: 17%

Where the shaft material is other than the materials specified in Clause 3.10.1 (c) above, the chemical composition and mechanical properties, including the corrosion fatigue strength in seawater, shall be equivalent.

NOTES:

1. Clauses 3.10.2, 3.10.3, 3.10.4 and 3.10.5 are based upon the materials having the above values of elongation and a user-specified value of Ultimate Tensile Strength (UTS). Assumptions for shaft material characteristics that are incorrect can invalidate the factors of safety inherent in these clauses.
2. The material characteristics of a particular shaft material can be determined by referring to the manufacturer's material data certificates, heat stamp identification details and other relevant test documentation. Such documentation is especially important where—
 - (a) any doubt exists as to the performance characteristics of the material;
 - (b) it is proposed to use carbon manganese steel having a specified UTS of greater than 510 MPa; or
 - (c) it is proposed to use a material having a UTS greater than 618 MPa.

3.10.2 Reference shaft diameter

The reference shaft diameter for use in Clauses 3.10.3 to 3.10.5 shall be determined by the following formula:

$$d_r = ak \sqrt[3]{\frac{P}{N}}$$

where

- d_r = reference shaft diameter, in millimetres
- a = 1.108 for vessels of Classes A, B and C; and 1.053 for vessels of Classes D and E
- k = 89 for propulsion through reduction gears or flexible couplings
- P = the maximum brake power (in kilowatts) that the engine will transmit, irrespective of the length of time nominated by the engine manufacturer for which the engine may be run at that power
- N = shaft revolutions per minute.

NOTES:

1. Many of the formulae for shafting and shafting components contained within Clauses 3.10, 3.11, 3.12 and 3.15 are based on "minimum required" rather than "as fitted" diameters in order to provide minimum scantlings. Designing to the minimum scantlings may limit flexibility with regard to future modifications to the vessel. In particular, this will be of concern if the vessel is to be refitted with machinery of increased power.
2. Values of coefficient k for direct-drive, in-line internal combustion engines may be obtained from Section 9 of the USL Code, dated 1 October 1993.

3.10.3 Solid propeller shaft size

Refer to Figure 5.

The diameter of the solid propeller shaft shall not be less than that determined by the following formula:

$$d_p = \left(1.14 d_r + \frac{D}{K} \right) f_p$$

where

- d_p = minimum diameter of propeller shaft, in millimetres
- d_r = reference diameter of shaft, in millimetres, calculated in accordance with Clause 3.10.2
- D = propeller diameter, in millimetres
- K = 144 for shafts protected against corrosion (see Clause 3.10.9)
- f_p = material factor for propeller shaft, determined in accordance with the following formula:

$$f_p = \sqrt[3]{\frac{410}{UTS_{Shaft}}}$$

where

UTS_{shaft} = ultimate tensile strength of the propeller shaft material, in megapascals (MPa).

NOTE: Certain high-tensile materials used for propeller shafting exhibit rapid deterioration in warm sea conditions, necessitating frequent withdrawal for inspection and possible replacement. Care should be taken to ensure that the shafting material chosen is suitable for the intended or likely area of operation.

3.10.4 Allowable reduction in propeller shaft diameter

The diameter of the part of the propeller shaft forward of the stern gland may be reduced from that calculated in Clause 3.10.3, provided that such reduction is as gradual as possible, and the diameter of the reduced part is calculated in accordance with the following formula:

$$d_{rp} = 1.14 d_r f_p$$

where

d_{rp} = minimum allowable diameter of reduced part of shaft, in millimetres

d_r = reference diameter of shaft in millimetres, calculated in accordance with Clause 3.10.2

f_p = the material factor used for calculating d_p (see Clause 3.10.3).

3.10.5 Solid Intermediate shaft size

The diameter of solid intermediate shafting shall not be less than that determined by the following formula:

$$d_i = d_r f_i$$

where

d_i = minimum diameter of intermediate shaft in millimetres

d_r = reference diameter of shaft in millimetres, calculated in accordance with Clause 3.10.2

f_i = material factor for intermediate shaft, determined in accordance with the following formula:

$$f_p = \sqrt[3]{\frac{410}{UTS_{Shaft}}}$$

where

UTS_{shaft} = ultimate tensile strength of the intermediate shaft material, in megapascals (MPa).

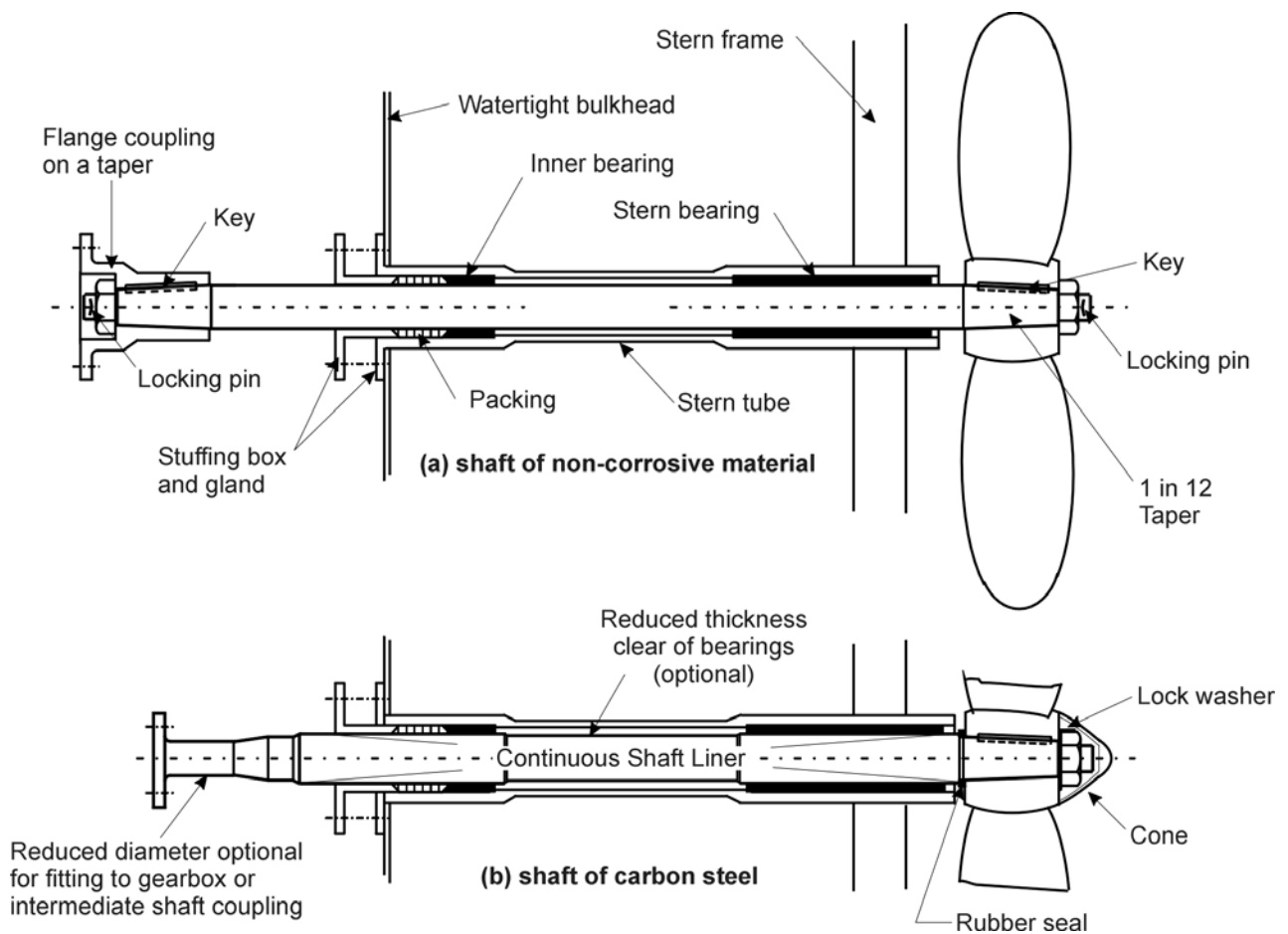

Figure 5 — Typical propeller shaft, stern tube, stern bearing and gland

3.10.6 Hollow shafting

Shafting may be hollow provided that it is of equivalent strength to a solid shaft. The required outside diameter of the shaft can be calculated from the following formula:

$$d_1 = \frac{d_s}{\sqrt[3]{1-y^4}}$$

where

d_1 = required outside diameter of hollow shaft, in millimetres

d_s = required diameter of solid shaft, in millimetres

y = a nominated ratio of d_2/d_1 ,

where

d_2 = the inside diameter of the hollow shaft.

3.10.7 Shaft support

Shafts shall be adequately supported. The maximum allowable distance between shaft supports shall be determined in accordance with the following formula:

$$S = 0.142 \sqrt[3]{d_f^2}$$

where

S = maximum allowable distance between centres of shaft supports, in metres

d_f = diameter of shaft fitted, in millimetres.

The forward-most bearing should be located at least 12 shaft diameters from the engine gearbox or thrust block flange.

NOTE: See also Clause 2.15.3.

3.10.8 Propeller shaft overhang

The overhang of the propeller shaft between the forward face of the propeller boss and the after face of the adjoining shaft bearing should not be more than the actual propeller shaft diameter. Where an overhang exceeds this, the bending stress due to the additional overhang shall be taken into account when calculating the required shaft diameter.

3.10.9 Protection of propeller shaft

Where exposure to water may corrode propeller shafts, they shall either be protected by a continuous, water-resistant liner complying with Clause 3.10.10 [see Figure 5 (b)], or the shaft shall run in an oil-lubricated stern tube with a sealing gland at the aft end. Protective coatings may be applied in lieu of a liner on those parts of the propeller shaft that are visible when the craft is slipped.

3.10.10 Liners

Liners, where fitted, shall be of bronze or stainless steel. Liners shall be shrunk on to the shaft. Securing pins shall not be used. The thickness of liners fitted in way of the bearings shall not be less than that calculated in accordance with the following formula:

$$t = \frac{d_f + f}{32}$$

where

t = thickness of the liner, in millimetres

d_f = fitted diameter of the shaft within the liner, in millimetres

f = material factor, as follows:

- a) 230 for bronze
- b) 120 for stainless steel.

The thickness of a continuous liner between bearings shall not be less than $0.75t$.

3.10.11 Propeller shaft tapers

Propeller shafts shall be tapered to provide an accurate fit in the propeller boss, with particular attention given to the fit at the large end of the taper. The taper shall be between the limits of 1 in 12 and 1 in 16 on the diameter, except on shafts less than 50 mm diameter, where a taper as steep as 1 in 10 on the diameter may be used.

The contact area between the mating surfaces prior to final pull-up shall be at least 70 per cent.

The roughness of the mating surfaces should not exceed 3.5 μm , and the forward edge at the bore of the boss should be well rounded.

NOTE: A taper of 1:12 on the diameter has been found to provide a good compromise between being shallow enough to ensure the propeller will remain secured on the taper, and being steep enough to facilitate removal of the propeller from the shaft.

3.11 KEYS AND KEYWAYS

3.11.1 Keys

Keys for propeller shafting shall be of the round ended or sled-runner type (see Figure 6 and Figure 7 and shall be of material compatible with the shaft to which they are to be fitted. The bottom of the keyway in the boss and shaft shall be parallel to the taper cone of the shaft.

Keys of the sled-runner type shall incorporate means to prevent the key from sliding in the keyway.

Sled-runner keys shall have two screwed pins for securing the key in the keyway, and the forward pin should be at least one-third of the length of the key from the large end of the taper. The depth of the countersink for the screwed pins should not exceed the pin diameter, and the edges of the hole should be slightly bevelled.

3.11.2 Keyways—general

The distance between the large end of the taper and the commencement of the keyway shall not be less than 0.2 times the required diameter of the shaft. A keyway for a round-ended key shall be contained wholly within the length of the taper. A keyway for a sled-runner key may run through the small end of the taper provided the keyway remains clear of both the propeller or taper flange coupling nut thread and the groove or radius at the transition between the thread and taper.

The depth of the keyway shall be 0.5 times the required thickness of the key (see Clause 3.11.6). The keyway shall have smooth fillets at the bottom. Any sharp edges at the top shall be removed. The radius of the fillet shall be at least 0.0125 times the fitted diameter of the shaft.

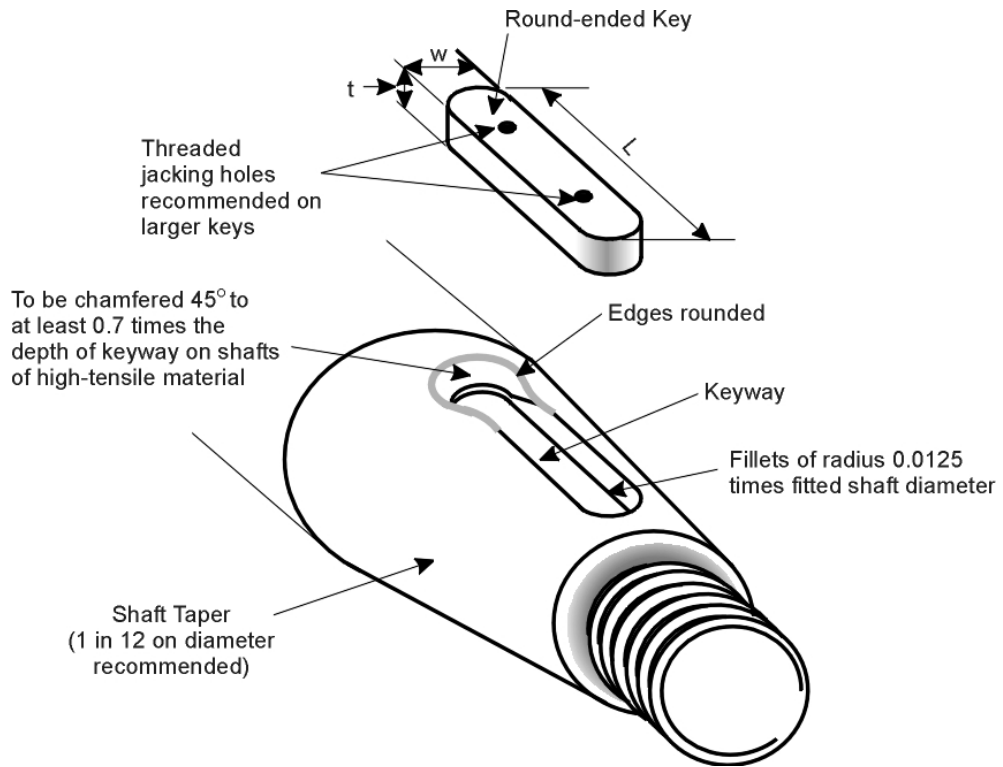

Figure 6 — Round-ended key and keyway (diagram shows arrangement suitable for a shaft of high-tensile material)

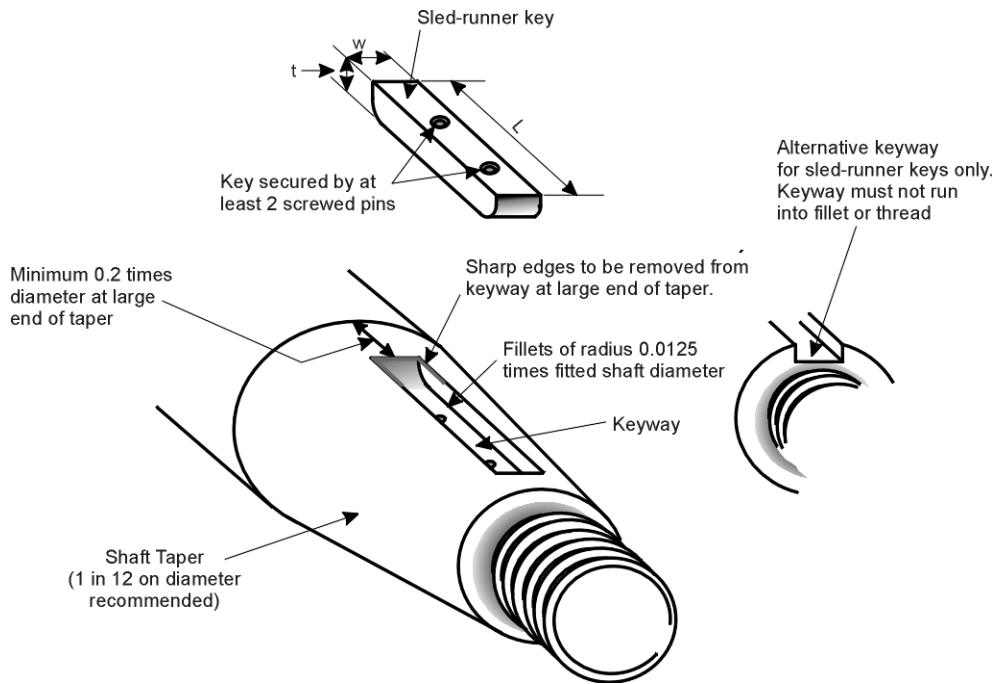

Figure 7 — Sled-runner key and keyway

3.11.3 Keyways—shafts of high-tensile material (UTS 800 MPa or greater)

The inward end of the keyway in shafts of high-tensile material shall be “relieved”. On round-ended keyways the relieving shall be chamfered to an angle of 45° from side to side to a depth at least 0.7 times the keyway depth. The edges so formed shall be rounded. Refer to Figure 6.

3.11.4 Calculated key width

The calculated key width shall be determined in accordance with the following formula:

$$w = \frac{d}{4}$$

where

w = calculated width of key, in millimetres

d = required diameter of propeller shaft or intermediate shaft (calculated in accordance with Clauses 3.10.3, and 3.10.4 or 3.10.5 respectively), in millimetres.

3.11.5 Calculated key length

The calculated key length shall be determined in accordance with the following formula:

$$l = 1.6 d$$

where

l = calculated length of the key, in millimetres

d = required diameter of the propeller shaft or intermediate shaft (calculated in accordance with Clauses 3.10.3, and 3.10.4 or 3.10.5 respectively), in millimetres.

3.11.6 Thickness of key

The thickness of a key shall be determined in accordance with the following formula:

a) For shafts less than 150 mm diameter—

$$t = 0.633 w + 0.94$$

b) For shafts of 150 mm diameter and over—

$$t = \frac{w}{2} + 6$$

where

t = required thickness of key, in millimetres

w = width of key, in millimetres, calculated in accordance with Clause 3.11.4.

3.11.7 Actual key width and length

The actual width and length of a key shall comply with the following:

- a) The actual key width w_a shall be within 15 per cent of the calculated key width w , and

$$l_a w_a \left(\frac{UTS_{key}}{UTS_{shaft}} \right) \geq \frac{d^2}{2.5}$$

where

- l_a = actual length of the key, in millimetres
- w_a = actual width of key in millimetres
- d = required diameter of the propeller shaft or intermediate shaft (calculated in accordance with Clauses 3.10.3, and 3.10.4 or 3.10.5 respectively), in millimetres
- UTS_{key} = ultimate tensile strength of the key material, in megapascals (MPa)
- UTS_{shaft} = ultimate tensile strength of the shaft material, in megapascals (MPa).

NOTE: The key material should have a UTS similar to that of the shaft material.

3.12 PROPELLER AND SHAFT COUPLINGS

3.12.1 Coupling materials

Couplings shall be manufactured from carbon steel or material of equivalent properties. Ordinary grades of cast iron shall not be used.

3.12.2 Coupling types

Couplings shall be of the following types:

- a) Flange couplings, with flanges formed by upsetting the ends of a shaft [see Figure 5 (b)].
- b) Flange couplings, with flanges of fabricated construction. Such couplings shall be heat treated subsequent to welding and machining.
- c) Flange couplings fitted on a taper, keyed and held in place with a nut [see Figure 5 (a)].
- d) Flange couplings shrunk on a parallel shaft with or without a key, pin, dowel or similar item in way of the shrink fit (provided that the couplings are not subject to removal in service).
- e) Flange couplings of the split boss type, keyed and clamped to parallel shafts (see Figure 8).
- f) Oil injection couplings.
- g) Clamp couplings of split type, keyed and clamped to parallel shafts.
- h) Flexible couplings.

NOTE: Flange couplings frequently incorporate a spigot to facilitate correct alignment during assembly.

3.12.3 Flange couplings

3.12.3.1 Coupling flange dimensions

The minimum thickness of a coupling flange shall be the greater of those determined from the formulae in Items (a) and (b) below:

$$\text{a) } t_f = 0.2 d_r \left(\frac{410}{UTS_{coup}} \right)$$

$$\text{b) } t_f = d_b \sqrt{\frac{UTS_{bolt}}{UTS_{coup}}}$$

where

- t_f = minimum flange thickness, in millimetres
- d_r = reference shaft diameter (calculated in accordance with Clause 3.10.2), in millimetres
- d_b = diameter of bolts at joint (calculated in accordance with Clause 3.12.3.3), in millimetres
- UTS_{coup} = ultimate tensile strength of coupling flange material, in megapascals (MPa)
- UTS_{bolt} = ultimate tensile strength of coupling bolts (of diameter calculated in accordance with Clause 3.12.3.3), in megapascals (Mpa).

The ligament thickness outside the coupling bolt holes shall not be less than 0.6 times the required coupling bolt diameter.

Proprietary couplings supplied by the manufacturer need not comply with the minimum ligament thickness requirement.

The fillet radius at the base of the flange shall not be less than 0.08 times the actual diameter of the shaft. Where the fillet radius is less than 0.125 times the actual diameter of the shaft, the surface finish of the fillet shall not be rougher than 1.6 μm .

NOTE: The dimensions of couplings for propeller and intermediate shafts calculated in accordance with the required diameter may be incompatible with some pre-fitted gearbox flanges. Options to overcome this problem include—

- a) adopting a reduced diameter of propeller shaft in accordance with Clause 3.10.4;
- b) using a higher strength material for propeller and intermediate shafts;
- c) using a higher strength material for the coupling; or
- d) replacing the gearbox coupling.

3.12.3.2 Coupling flange boss

The minimum boss thickness (outside the keyway) of flange couplings fitted on a taper shall not be less than 1.5 times the required thickness of the key. The minimum thickness shall be measured at the large end of the taper.

The minimum thickness of a coupling flange boss on a parallel shaft should not be less than that calculated from the following formula:

$$t_b = 0.11 d \left(0.9 \left(\frac{UTS_{shaft}}{UTS_{coup}} \right) + 0.1 \right) + 0.75 \left(\frac{d + 32}{120} \right) \left(\frac{618}{UTS_{coup}} \right) + \frac{t_k}{2}$$

where

- t_b = minimum thickness of coupling flange boss, in millimetres
- d = minimum required shaft diameter (calculated in accordance with Clauses 3.10.3 and 3.10.4 or 3.10.5), in millimetres
- UTS_{shaft} = ultimate tensile strength of shaft material, in megapascals (MPa)
- UTS_{coup} = ultimate tensile strength of coupling material, in megapascals (MPa)
- t_k = actual thickness of key, in millimetres.

The length of the boss shall not be less than 1.6 times the minimum required shaft diameter or the key length, whichever is the greater.

3.12.3.3 Flange coupling bolts

3.12.3.3.1 Fitting

Flange coupling bolts shall be machine finished and neat fitting. Non-fitted bolts may be used in couplings that incorporate a spigot provided the bolts are torqued to the coupling manufacturer's recommendations.

3.12.3.3.2 Diameter

Flange coupling bolts shall have a diameter not less than that calculated from the following formula:

$$d_b = \left(0.54 \sqrt{\frac{d_r^3}{N r}} \right) \sqrt{\frac{410}{UTS_{bolt}}}$$

where

- d_b = diameter of bolts at joint, in millimetres
- N = number of bolts fitted in one coupling
- r = pitch circle radius of bolts, in millimetres
- d_r = reference shaft diameter (calculated in accordance with Clause 3.10.2), in millimetres
- UTS_{bolt} = ultimate tensile strength of flange coupling bolt, in megapascals (MPa).

3.12.4 Propeller and taper flange couplings

3.12.4.1 Tapers

Tapers for taper flange couplings shall be as specified for propeller shaft tapers in Clause 3.10.11.

3.12.4.2 Propeller and taper flange coupling retaining nuts

Retaining nuts shall be manufactured from a material compatible with that of the propeller or shaft to which they are to be fitted. They shall also comply with the following:

- a) The outside diameter of the threads shall not be less than 0.75 times the diameter at the smaller end of the taper.
- b) The depth over which the nut is fully threaded shall not be less than 0.75 of the diameter of the thread.
- c) The width across the flats or the effective outside diameter of the nut shall not be less than 1.5 times the diameter of the thread.
- d) Nuts shall be fitted with locking devices. The propeller nuts fitted to carbon steel shafts shall be cap nuts.

3.12.4.3 Pitch of propeller retaining nut threads

The pitch of the thread for propeller retaining nuts shall be in accordance with an applicable and recognised national or international standard (e.g. ISO 4566), or the following:

- a) 2.5 mm pitch for thread diameters not exceeding 40 mm.
- b) 3.5 mm pitch for thread diameters of 40 mm and not exceeding 75 mm.
- c) 4 mm pitch for thread diameters of 75 mm and not exceeding 100 mm.
- d) 6 mm pitch for thread diameters exceeding 100 mm.

The thread form should be metric.

NOTE: Threads for taper flange coupling retaining nuts are frequently made the same as for propeller retaining nuts to permit the propeller shaft to be turned end for end in the event of wear down in way of the stern bearings.

3.12.5 Split flange and clamp couplings

3.12.5.1 Clamping bolts

The diameter at the bottom of the threads of bolts in split flange and clamp couplings shall not be less than that determined by the following formula:

$$d_b = \left(0.33 \sqrt{\frac{d_r^3}{N r}} \right) \sqrt{\frac{410}{UTS_{bolt}}}$$

where

d_b = diameter of bolts, in millimetres

N = number of clamp bolts at one of the shaft ends

- r = distance, in millimetres, between the centre of the bolts and the centre line of the shaft
- d_r = reference shaft diameter (calculated in accordance with Clause 3.10.2), in millimetres
- UTS_{bolt} = ultimate tensile strength of clamp coupling bolt, in megapascals (MPa).

3.12.5.2 **Astern thrust**

A minimum of two fitted cotter bolts per shaft end shall be let into the shaft between 0.25 times and 0.5 times their diameter to take the astern thrust (see Figure 8).

3.12.6 **Flexible couplings**

3.12.6.1 **Universal joint couplings**

Universal joints may be incorporated in those parts of the propulsion shafting not subject to axial loading. Universal joint couplings shall be designed and constructed to withstand the maximum engine torque.

The installation shall be such as to minimise stressing due to cyclic irregularities.

Means shall be provided to prevent the possibility of personal injury or damage to the hull or structure of the vessel due to a failure of the universal joint causing flailing of the shaft.

3.13 **STERN BEARINGS**

3.13.1 **General**

Stern bearings shall be of the grease-, oil- or water-lubricated type. Grease- and oil-lubricated bearings shall be fitted with an oil seal. Water-lubricated bearings shall be lined with rubber compound or appropriate synthetic material.

3.13.2 **Length of stern bearings**

Plain water-, grease-, or oil-lubricated bearings shall have a length not less than that determined from the following formula:

$$l_s = k_b d_p$$

where

- l_s = length of stern bearing, in millimetres
- k_b = factor of 4 for water- or grease-lubricated bearings; or factor of 2 for oil-lubricated bearings
- d_p = required diameter of propeller shaft (calculated in accordance with Clause 3.10.3), in millimetres.

Propeller shaft stuffing box support bearings, if fitted, should be no less than 50 per cent the length of the stern bearing as calculated above.

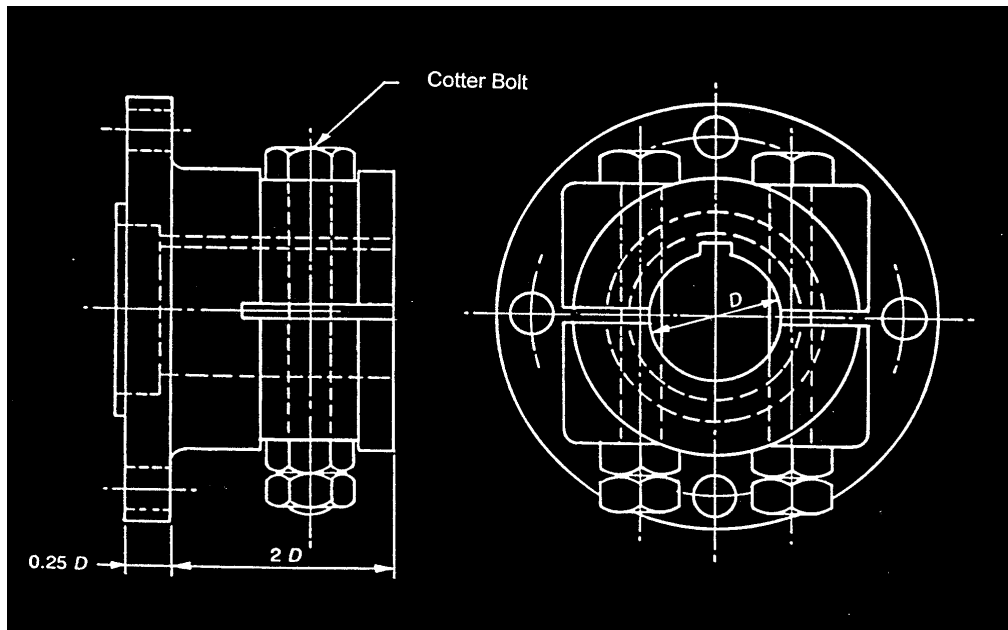

Figure 8 — Split flange coupling

3.13.3 Proprietary bearing materials

The minimum length of a water- or grease-lubricated bearing may be reduced where proprietary types are used in accordance with the manufacturer's recommendations. In no case should the bearing have a length less than that given by the formula in Clause 3.13.2 using a value for k_b of 2.

3.13.4 Oil-lubricated bearings

In addition to the requirement given in Clause 3.13.2 above, an oil-lubricated bearing shall be of a length sufficient to ensure that the bearing pressure resulting from the mass of the propeller and propeller shafting will not exceed 480 kPa.

3.14 STERN TUBES AND STERN GLANDS OR SEALS

3.14.1 Stern tubes

Stern tubes shall be rigid and shall be integrated into the structure of the vessel. A stern tube shall be of a thickness sufficient to support any shaft bearings carried within the stern tube, and shall allow for a 25 per cent reduction in thickness due to corrosion and erosion. The thickness of the stern tube shall not be less than that of the hull shell to which it is attached.

NOTE: The thickness of the stern tube must be sufficient to allow for boring, support of bearings, welding and/or integration into the structure. The stern tube thickness is typically 1.5 times the equivalent hull shell thickness. The stern tube thickness in way of the housings of bearings is typically increased to 5 per cent of the shaft diameter plus 10 mm.

3.14.2 Stern gland or seal

The stern gland or seal at the forward end of the stern tube shall be accessible for inspection and adjustment.

3.14.3 Mechanical seals

Mechanical seals may be fitted provided they are type approved by a Classification Society.

3.14.4 Flexible stern glands

Flexible stern glands may be fitted where the propeller shaft is not greater than 64 mm in diameter. The gland shall be connected to the stern tube by steel-reinforced synthetic rubber hose. The hose shall be secured at each end by two corrosion-resistant clips. Rotational movement of the gland shall be limited by stops to no more than 5° either side of the mean position.

3.15 PROPELLER SHAFT BRACKETS**3.15.1 Bearings****3.15.1.1 Bearing length**

Plain grease- or water-lubricated bearings shall have a length not less than that determined from the formula in Clause 3.13.2 using a value for k_b of 4.

3.15.1.2 Proprietary bearing materials

The minimum length of bearing may be reduced where proprietary types are used in accordance with the manufacturer's recommendations. In no case should the bearing have a length less than that given by the formula in Clause 3.13.2 using a value for k_b of 2.

3.15.1.3 Boss length

Boss length shall be sufficient to fully support the shaft bearing.

3.15.1.4 Boss thickness

Boss thickness should not be less than that determined from the following formula:

$$t_{boss} = 0.2 d_p \left(\frac{UTS_{shaft}}{UTS_{bracket}} \right)$$

where

- t_{boss} = required minimum thickness of boss, in millimetres
- d_p = required diameter of propeller shaft (calculated in accordance with Clause 3.10.3), in millimetres
- UTS_{shaft} = ultimate tensile strength of shaft material, in megapascals (MPa)
- $UTS_{bracket}$ = ultimate tensile strength of bracket material, in megapascals (MPa).

3.15.2 Brackets of 'V' Configuration

Refer to Figure 9 (a)

3.15.2.1 Included angle between legs

The included angle between the legs shall not be less than 45°.

NOTES:

1. Bracket leg angle should be carefully selected to prevent interaction between propeller blades and bracket legs. Aerofoil sections require special attention.
2. The scantlings for V-brackets derived from the deemed to satisfy clauses in this Chapter are based on legs having an included angle not less than 45°.

3.15.2.2 Calculated width

The calculated width of each solid streamlined leg shall be obtained from the following formula:

$$W = 2.27 d_p \sqrt[3]{\frac{UTS_{shaft}}{UTS_{leg}}}$$

where

- W = calculated width of leg (major axis), in millimetres
- d_p = required diameter of propeller shaft (calculated in accordance with Clause 3.10.3), in millimetres
- UTS_{shaft} = ultimate tensile strength of shaft material, in megapascals (MPa)
- UTS_{leg} = ultimate tensile strength of leg material, in megapascals (MPa).

3.15.2.3 Calculated thickness

The calculated thickness of each solid streamlined leg shall be obtained from the following formula:

$$t = 0.35 d_p \sqrt[3]{\frac{UTS_{shaft}}{UTS_{leg}}}$$

where

- t = calculated thickness of leg (minor axis), in millimetres
- d_p = required diameter of propeller shaft (calculated in accordance with Clause 3.10.3), in millimetres
- UTS_{shaft} = ultimate tensile strength of shaft material, in megapascals (MPa)
- UTS_{leg} = ultimate tensile strength of the leg material, in megapascals (MPa).

3.15.3 Brackets of 'I' Configuration

Refer to Figure 9 (b)

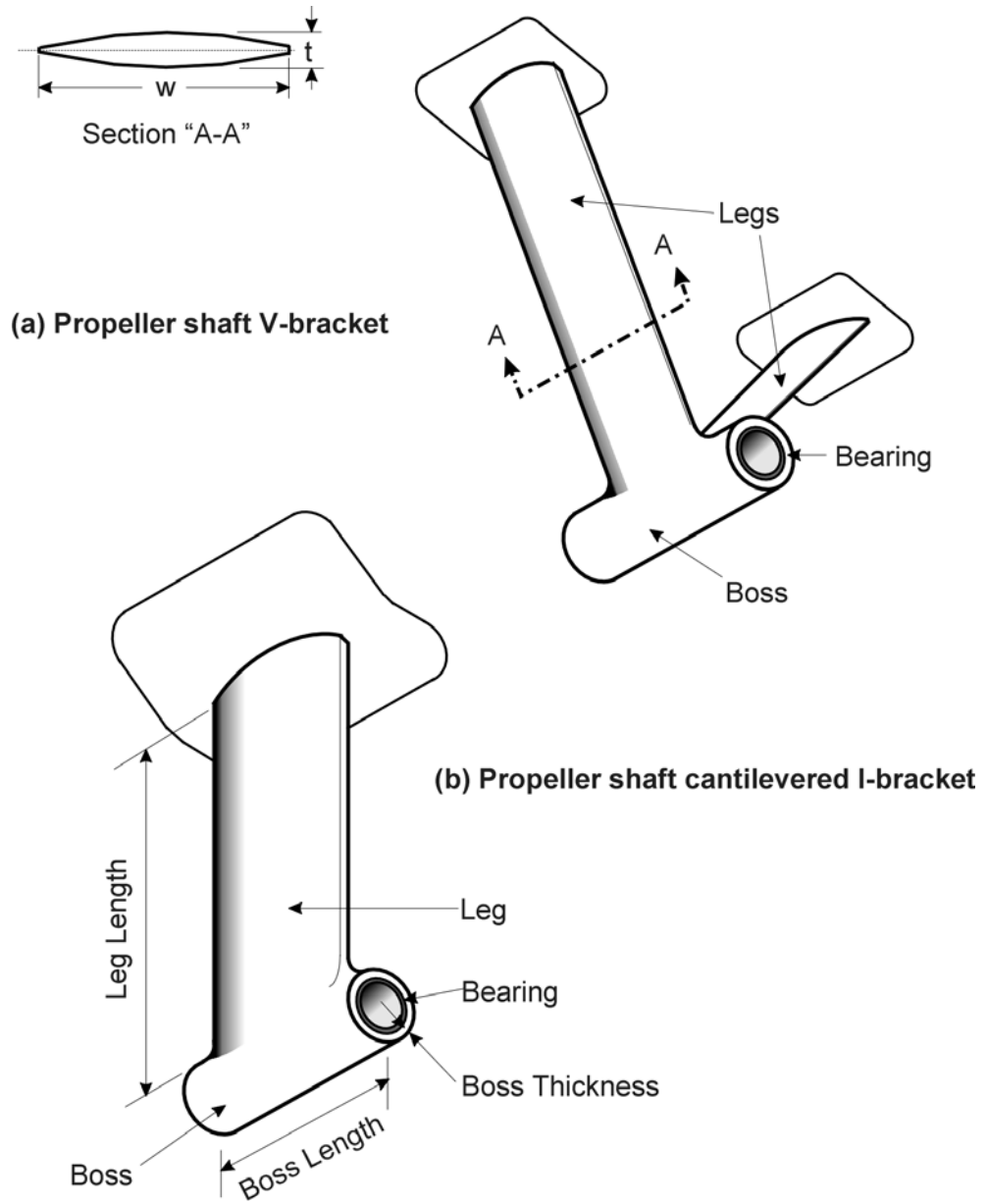

Figure 9 — Propeller shaft brackets

3.15.3.1 Calculated width

The calculated width of the single solid streamlined leg shall be obtained from the following formula:

$$W_1 = 3.22 d_p \sqrt[3]{\frac{UTS_{shaft}}{UTS_{leg}}}$$

where

- W_1 = calculated width of leg (major axis), in millimetres
- d_p = required diameter of propeller shaft (calculated in accordance with Clause 3.10.3), in millimetres
- UTS_{shaft} = ultimate tensile strength of shaft material, in megapascals (MPa)
- UTS_{leg} = ultimate tensile strength of leg material, in megapascals (MPa).

3.15.3.2 Calculated thickness

The calculated thickness of the single solid streamlined leg shall be obtained from whichever of the following formulae is appropriate:

- a) Where the leg is a cantilever—

$$t = 0.515 d_p \sqrt[3]{\frac{UTS_{shaft}}{UTS_{leg}}}$$

- b) Where the lower end of the leg is attached to a shoe piece or skeg that offers lateral support, see Clause 6.8.7.2—

$$t = 0.36 d_p \sqrt[3]{\frac{UTS_{shaft}}{UTS_{leg}}}$$

where

- t = calculated thickness of the leg (minor axis), in millimetres
- d_p = required diameter of propeller shaft (calculated in accordance with Clause 3.10.3), in millimetres
- UTS_{shaft} = ultimate tensile strength of shaft material, in megapascals (MPa)
- UTS_{leg} = ultimate tensile strength of leg material, in megapascals (MPa).

3.15.4 Additional provisions for bracket design**3.15.4.1 Stiffness**

Where the bracket is a material other than carbon steel, the moment of inertia about the longitudinal axis shall not be less than that determined from the following formula:

$$I_l = \frac{w t^3}{250000} \left(\frac{UTS_{leg}}{UTS_{shaft}} \right)^{\frac{4}{3}} \left(\frac{207}{E_{leg}} \right)$$

where

- I_l = required moment of inertia of the leg about the longitudinal axis, in cm^4
- w = calculated width of leg as determined by Clause 3.15.2.2 or 3.15.3.1 as appropriate, in millimetres
- t = calculated thickness of leg as determined by Clause 3.15.2.3 or 3.15.3.2 as appropriate, in millimetres
- UTS_{shaft} = ultimate tensile strength of shaft material, in megapascals (MPa)
- UTS_{leg} = ultimate tensile strength of leg material, in megapascals (MPa)
- E_{leg} = modulus of elasticity of the leg material, in gigapascals (GPa).

3.15.4.2 Hollow section and non-streamlined brackets

Where the bracket is a hollow or non-streamlined section, the cross-sectional area, inertia and section modulus of the leg about the longitudinal axis shall be maintained. For the purposes of such calculation, the section modulus shall not be less than that determined from the following formula:

$$Z_l = \frac{w t^2}{12500}$$

where

- Z_l = required section modulus of the leg about the longitudinal axis, in cubic centimetres (cm^3)
- w = calculated width of leg as determined by Clause 3.15.2.2 or 3.15.3.1 as appropriate, in millimetres
- t = calculated thickness of leg as determined by Clause 3.15.2.3 or 3.15.3.2 as appropriate, in millimetres.

The area of the leg shall not be less than that determined from the following formula:

$$A = 0.0061 w t^3 \sqrt[3]{\frac{UTS_{shaft}}{UTS_{leg}}}$$

where

- A = required area of the leg, in square centimetres (cm^2)
- w = calculated width of leg as determined by Clause 3.15.2.2 or 3.15.3.1 as appropriate, in millimetres

- t = calculated thickness of leg as determined by Clause 3.15.2.3 or 3.15.3.2 as appropriate, in millimetres
- UTS_{shaft} = ultimate tensile strength of shaft material, in megapascals (MPa)
- UTS_{leg} = ultimate tensile strength of leg material, in megapascals (MPa).

3.15.4.3 Leg length

The above formulas have been based on a given maximum length for the longer leg of a “V” bracket or the leg of an “I” bracket. The maximum assumed length, measured from the outside perimeter of the boss to the outside of the shell plating, shall be determined from the following formula:

$$l_{max} = 10.6 d_p \sqrt[3]{\frac{UTS_{shaft}}{410}}$$

where

- l_{max} = maximum length of leg, in millimetres, for application of the formulae in Clauses 3.15.2 to 3.15.3
- d_p = required diameter of propeller shaft (calculated in accordance with Clause 3.10.3), in millimetres
- UTS_{shaft} = ultimate tensile strength of shaft material, in megapascals (MPa).

Where the leg length is less than l_{max} , the section modulus of the leg may be reduced in proportion to the reduced length, provided the section modulus is not less than 0.85 times the required section modulus Z_l .

NOTE: Where the length l_{max} is exceeded, the scantlings of shaft brackets will need to be considered as an equivalent solution. The width and thickness of the legs or leg would normally increase to compensate for the increased bending loads and reduced buckling strength.

3.16 FIXED NOZZLES

3.16.1 General

Fixed nozzles shall be watertight and tested to a head of water of 2.5 m or equivalent. A means for draining shall be incorporated in the nozzle.

3.16.2 Scantlings of fixed nozzles

The scantlings of fixed nozzles shall be calculated in accordance with Clauses 6.10.2 to 6.10.8 for steering nozzles.

3.17 STERN DRIVES, AZIMUTHING PROPELLERS, WATER JETS AND OTHER PROPRIETARY PROPULSION DEVICES

3.17.1 General

Stern drives, azimuthing propellers, water jets and other proprietary propulsion devices may be fitted instead of conventional shafting provided

the reliability of the propulsion system and the watertight integrity of the vessel are maintained, refer also to Clauses 3.17.2 to 3.17.4 below.

3.17.2 Rating

The manufacturer's specified rating for a proprietary propulsion device shall be appropriate for the intended nature and use of the vessel. For vessels 25 m and over in measured length, the proprietary propulsion device shall be of a design and construction approved by a classification society.

NOTE: Not all proprietary propulsion devices are intended for commercial service. Some are rated by the manufacturer for recreational service only. Others may be rated for only recreational and light duty commercial service.

3.17.3 Astern thrust and directional control

Subject to Clause 2.14.5, sufficient astern thrust and directional control mechanisms shall be provided to secure proper control of the craft in normal and abnormal circumstances. The means for reversing and directional control shall provide for operation at full power under all normal conditions of operation.

On Seagoing vessels arrangements should be provided to permit the vessel to return to a safe haven in the event of a steering failure.

NOTE: On twin-screw vessels, this may involve the fitting of a locking device on each unit to maintain directional control.

3.17.4 Maintenance of watertight integrity

Where a proprietary propulsion device has features which have the potential to reduce the watertight integrity of the vessel (e.g. a flexible seal at the point where a propulsion device penetrates the hull), measures shall be taken to control any risks associated with such features, to ensure a risk not greater than that of a conventional installation.

NOTE: Such measures might include periodic replacement of the seal, the fitting of bilge level indicators, isolation of the propulsion unit in a watertight compartment or a combination of these.

CHAPTER 4 FUEL SYSTEMS

4.1 SCOPE

This Chapter applies to fuel tanks and fuel system components on vessels of less than 35 m in measured length.

NOTE: For vessels of 35 m or more in measured length, refer to Clause 1.2.1.

4.2 OBJECTIVE

The objective of this Chapter is to control the risks associated with the fuel system installation or a failure in the fuel system installation.

NOTES:

1. Hazards associated with fuel system installations or a failure of fuel system installations include: spillage of fuel caused by rupture of a fuel tank, rupture of piping or overflowing of fuel, contact of fuel with hot surfaces or other sources of ignition, ignition of explosive fumes, fuel contamination.
2. Consequences that may arise from a fuel system installation include: fire, explosion, loss of vessel propulsion, loss of emergency systems, personal injury and environmental pollution.

REQUIRED OUTCOMES

4.3 CONTAINMENT OF FUEL

Fuel tanks and fuel systems must be designed, constructed and installed to prevent the spillage of fuel in both normal and abnormal conditions of operation.

4.4 MINIMISING THE RISK OF IGNITION

Fuel tanks and fuel systems must be designed, constructed and installed to avoid potential sources of ignition arising from the proximity of machinery or other sources of ignition.

4.5 MINIMISING THE RISK OF EXPLOSION

Fuel tanks and fuel systems for fuel of flashpoint less than 60°C must be designed, constructed and installed to prevent the build-up of explosive fumes and avoid potential sources of ignition that might ignite such fumes.

DEEMED-TO-SATISFY SOLUTIONS

4.6 COMPLIANCE

For the purpose of this National Standard, the fuel system of a vessel shall be deemed to have satisfied the Required Outcomes in Clauses 4.3 and 4.5 if it complies with Clauses 4.7 to 4.10.

4.7 FUEL TANKS

For the purposes of this Chapter, fuel tanks are classified as portable or non-portable as follows:

Non-portable fuel tanks—
fuel tanks that are either—

- a) built-in fuel tanks—Fuel tanks that are integral to the vessel's hull structure. The requirements for built-in fuel tanks are specified in Clauses 4.7.1 and 4.7.2 (Further requirements for the fuel systems for such tanks are specified in Clause 4.9); or
- b) non-portable, freestanding fuel tanks—Fuel tanks that are not integral to the hull structure of the vessel, but which are nevertheless fitted to or permanently located on the vessel, and intended to be refilled *in situ*. The requirements for non-portable, free-standing fuel tanks are specified in Clauses 4.7.1 and 4.7.3. (Further requirements for the fuel systems of non-portable freestanding tanks are specified in Clauses 4.9 or 4.10).

Portable fuel tanks—

fuel tanks of 25 L capacity or less, and which are intended to be removed from the vessel for filling. The requirements for portable fuel tanks are specified in Clause 4.7.4.

4.7.1 Common requirements for non-portable fuel tanks of both free-standing and built-in types

4.7.1.1 Location

Non-portable fuel tanks shall not be fitted in the following locations:

- a) Over stairways and ladders.
- b) Over hot surfaces.
- c) Over electrical equipment.
- d) In any location where fuel from the tank would leak directly on a source of ignition.

This requirement need not apply where the fuel tank is supplied as an integral part of an engine.

4.7.1.2 Pressure testing

A non-portable fuel tank shall be pressure tested to an equivalent of 2.5 m of fresh water above the top of the tank, or to the maximum head to which the tank may be subject to in service, whichever is the greater.

The distance from the top of the air pipe or filling pipe, whichever is the greater, shall be taken into account in determining the head.

Non-portable, free-standing fuel tanks shall be pressure tested prior to installation in the vessel.

4.7.1.3 Venting

A non-portable fuel tank shall be vented to the open air. The size of the vent pipe shall be sufficient to prevent generation of pressure. Where the tank filling is effected by pumping through the filling line, the area of air escape shall not be less than 1.25 times the area of the filling pipe. Where more than one fuel tank is fitted, the vents shall be kept separate.

The pipe shall terminate in a gooseneck on the open deck, with the height of the lower face at the uppermost part of the bend equal to or greater than the height specified in Part C Subsection 2A (Watertight and Weathertight

Integrity—Load Line Vessels), or Part C Subsection 2B (Watertight and Weathertight Integrity—Non Load Line Vessels) of the NSCV.

Where the diameter of the pipe outlet exceeds 18 mm, a corrosion-resistant wire gauze screen shall be fitted. The open area of the screen shall be not less than the cross-section of the vent pipe.

A short flexible section of hose of length no more than 760 mm may be incorporated into the vent pipe for vibration damping or to facilitate installation. The flexible section of hose shall be made of reinforced synthetic rubber of a type resistant to fuel, salt water and vibration.

The flexible section of hose shall be fastened to the rigid section of the vent with two corrosion-resistant clips at each end.

4.7.1.4 Inspection opening

Non-portable fuel tanks, unless they are of the freestanding type and less than 800 L capacity, shall be fitted with an inspection opening to facilitate cleaning and inspection.

4.7.1.5 Fuel shut-off

A fuel shut-off valve or cock shall be fitted in each tank outlet line. Non-metallic piping and fittings shall not be fitted in the line between the tank and this shut-off valve or cock. The fuel shut-off valve or cock shall be provided with a means of closing located outside a machinery space in a position not likely to be isolated by a fire in the machinery space. Where remote fuel shut-off arrangements lead from or pass through a machinery space, they shall be capable of operating when exposed to flame and heat from a fire within that space.

NOTE: Locating the fuel shut-off valve on or near the fuel tank reduces the risk of uncontrolled fuel spillage in the event of a rupture in the pipe between the shut-off valve and the tank.

4.7.1.6 Fuel filling stations

Fuel filling stations shall be located outside machinery spaces and shall be arranged to—

- a) prevent any possibility of overflow coming into contact with a hot surface; and
- b) prevent or minimise pollution of the environment by any possible overflow.

4.7.1.7 Filling pipes for non-portable fuel tanks

Non-portable fuel tanks shall incorporate a permanent filling pipe. The filling pipe should extend from the open deck to the tank.

A short flexible section of hose of length no more than 760 mm may be incorporated into the filling pipe for vibration damping or to facilitate installation. The flexible section of hose shall be made of reinforced synthetic rubber of a type resistant to fuel, salt water and vibration and shall comply with a relevant national or international standard.

The flexible section of hose shall be fastened to the rigid section of the filling pipe with two corrosion-resistant clips at each end.

NOTES:

1. The use of flexible sections of hose in filling pipes that are also used for sounding may prevent proper soundings being taken unless the pipe is straight and a sounding tape is not used.
2. Electrical bonding similar to that mandated in Clause 4.10.10 for fuel systems of flashpoint less than 60°C is considered to be good practice on vessels having fuel of flashpoint 60°C or more.

4.7.2 Specific requirements for built-in fuel tanks which are integral to the vessel's hull structure

4.7.2.1 Construction

Built-in fuel tanks integral to the vessel's hull structure shall comply with the relevant provisions of Part C Section 3 (Construction) of the NSCV.

4.7.2.2 Arrangement

Fuel tanks shall not be located forward of the collision bulkhead. Built-in fuel tanks should be located to reduce the risk of spillage in the event of minor collisions or grounding.

NOTE: Cofferdams are used to separate fuel tanks from potable water tanks, see Part C Section 1 (Arrangement, Accommodation and Personal Safety) of the NSCV.

4.7.2.3 Fuels having a flashpoint below 60°C

Built-in fuel tanks shall not be used to contain fuels having a flashpoint below 60°C.

4.7.2.4 Sandwich construction

Sandwich construction shall not be used in way of built-in fuel tanks.

4.7.2.5 Large built-in tanks

Deep tanks and double bottom tanks extending more than half the breadth of the vessel shall be subdivided with a longitudinal division.

4.7.2.6 Baffles

Baffle plates shall be fitted in built-in fuel tanks to reduce the surging of the tank contents. Baffles should be fitted at intervals not more than 1 m along either the longitudinal or transverse axis of the tank. Access openings through baffles should be the minimum size required for inspection and cleaning in order to maintain their effectiveness as baffles.

NOTE: Baffles are usually fitted perpendicular to the axis of larger dimension. They are not normally provided along both axes.

4.7.3 Specific requirements for non-portable, free-standing fuel tanks

4.7.3.1 Construction

Non-portable, free-standing fuel tanks shall be constructed of carbon steel, stainless steel, copper, marine-grade aluminium alloy or FRP. No part of a metallic fuel tank shall depend on soft solder for tightness.

4.7.3.2 Location

Non-portable, free-standing fuel tanks should be located or arranged to permit inspection of the exterior of the tank and the hull and structure adjacent to the tank.

NOTE: Non-portable fuel tanks in machinery spaces are also required to comply with the fire rating requirements contained in Part C Section 4 (Fire Safety) of the NSCV.

4.7.3.3 Support and securing

Non-portable, free-standing fuel tanks shall be adequately supported and braced to prevent dislodging due to high accelerations that might arise through motions at sea or by a collision. The supports and braces shall be insulated from contact with the tank surfaces with a non-abrasive and non-absorbent material compatible with the tank material.

4.7.3.4 Baffles

Baffles shall be fitted in non-portable, free-standing fuel tanks at a spacing not greater than 1 m along the length of the tank (tank major axis), and shall have a thickness not less than that of the tank plating or tank shell laminate.

4.7.3.5 Minimum thickness—metallic tanks

The minimum thickness of metal used in the construction of a non-portable, free-standing fuel tank shall be the greater of the two values determined in accordance with Items a) and b) as follows:

- a) The thickness determined using the formulas in Clauses 4.7.3.7, 4.7.3.8 or 4.7.3.9 as appropriate, based on the dimensions of the largest unsupported panel.
- b) The thickness determined from the following formula:

$$t_{min} = 3 \sqrt{\frac{410}{UTS_{tank}}}$$

where

t_{min} = minimum plate thickness of tank, in millimetres

UTS_{tank} = welded ultimate tensile strength of tank material, in megapascals (MPa).

NOTE: The minimum thickness determined by the formula in Clause 4.7.3.5 (b) equates to 3 mm for carbon steel, 2.4 mm for 316 stainless steel and between 3.7 mm and 4.7 mm for aluminium depending upon the grade. Where material of the calculated thickness is not readily available, the preferred stock thickness of material in excess of that required is normally used.

4.7.3.6 Largest unsupported span—carbon steel tanks

When determining the largest unsupported panel for use in Clauses 4.7.3.7 and 4.7.3.8, account shall be taken of the support afforded by the following items:

- a) Tank boundaries.
- b) Baffles, where the thickness of the baffle is not less than the thickness of the tank plating in way (see Clause 4.7.3.4).

- c) Stiffeners, where—
- i) the thickness of the stiffener is not less than the thickness of the tank plating in way; and
 - ii) the depth of the stiffener is not less than that determined from the following formula:

$$d = 12 + \frac{b}{10}$$

where

- d = depth of stiffener in carbon steel, in millimetres
 b = unsupported span of stiffener, in millimetres.

4.7.3.7 Carbon steel tank of depth not exceeding 2.5 m

Where the depth from the top of the filling pipe to the bottom of a non-portable, free-standing carbon steel fuel tank does not exceed 2.5 m, the minimum plate thickness of carbon steel shall be obtained from Figure 10, which is developed from the following formula:

$$t = 0.024 a c$$

where

- t = minimum carbon steel plate thickness, in millimetres
 a = length of minor axis, in millimetres
 c = corresponding numerical value for the ratio of length of major axis of panel l to length of minor axis of panel a , as given in Table 2
 l = length of major axis, in millimetres.

4.7.3.8 Carbon steel tank of depth exceeding 2.5 m

Where the depth from the top of the filling pipe to the bottom of a non-portable, free-standing carbon steel tank exceeds 2.5 m, the minimum plate thickness of carbon steel shall be calculated from the following formula:

$$t = 0.024 a c \sqrt{\frac{h}{2.5}}$$

where

- t = minimum carbon steel plate thickness, in millimetres
 a = length of minor axis, in millimetres
 c = corresponding numerical value for the ratio of length of major axis of panel l to length of minor axis of panel a , as given in Table 2
 h = distance from top of filling pipe to bottom of tank, in metres
 l = length of major axis, in millimetres.

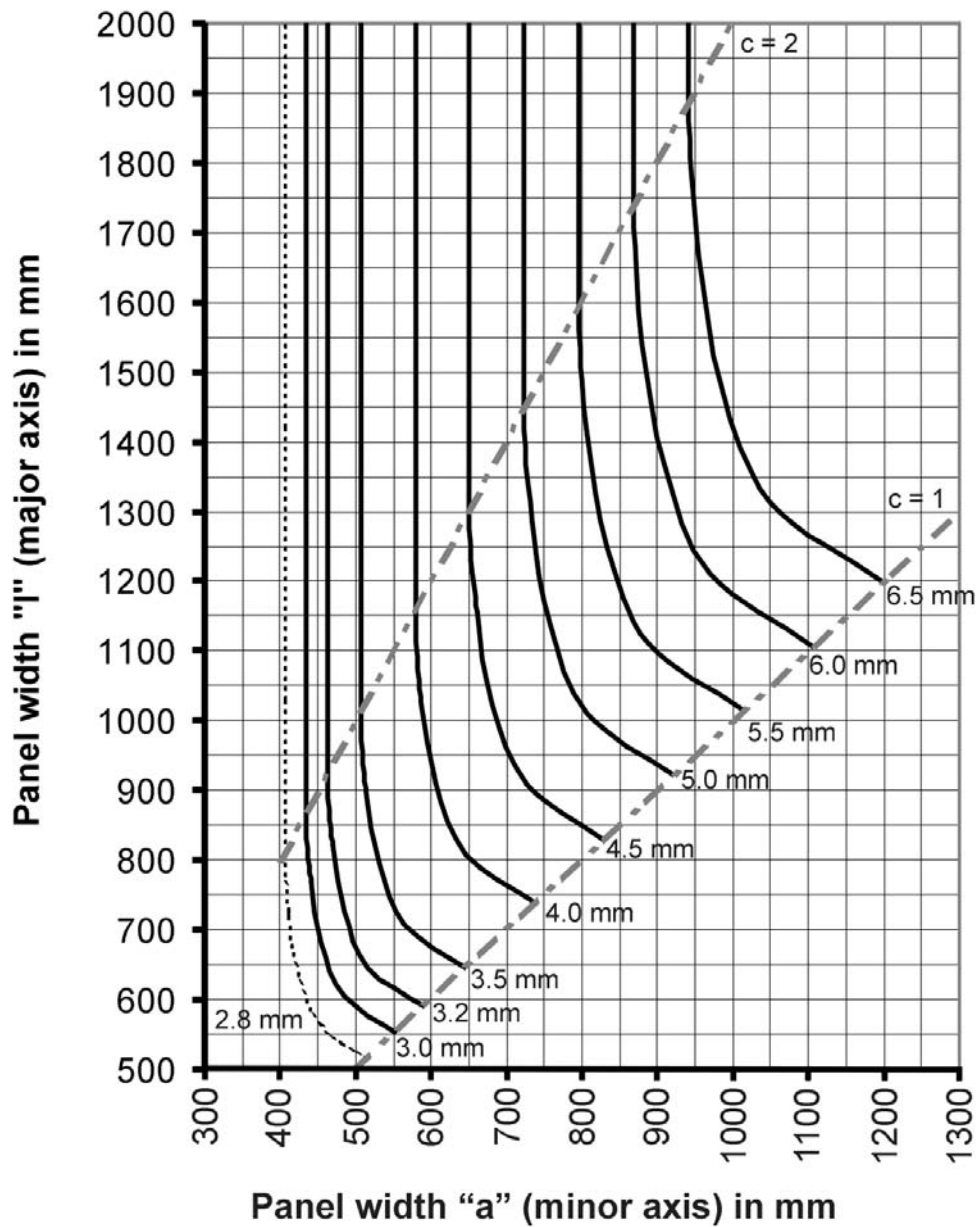

Figure 10 — Minimum thickness of fuel tanks plated in carbon steel for heads not exceeding 2.5 m

Table 2 — Ratio of major/minor axes of panel (l/a)

l/a	1	1.25	1.5	1.75	2 and over
c	0.226	0.258	0.275	0.284	0.288

NOTE: Values for coefficient c corresponding to values of l/a between those shown in the table may be obtained by linear interpolation.

4.7.3.9 Metallic tanks manufactured from metal other than carbon steel

Where a fuel tank is manufactured from a metal other than carbon steel, the plate thickness shall be determined from the following formula:

$$T = t \sqrt{\frac{410}{UTS_{tank}}}$$

where

- T = minimum plate thickness of tank, in millimetres
- t = minimum plate thickness, in millimetres, for carbon steel, determined in accordance with Clause 4.7.3.7 or 4.7.3.8 as appropriate
- UTS_{tank} = ultimate tensile strength of tank material, in megapascals (MPa).

Where the stiffener material is a metal other than carbon steel, the minimum depth of stiffener referred to in Clause 4.7.3.6 (c) shall be determined from the following formula:

$$D = d \sqrt[4]{\frac{410}{UTS_{tank}}}$$

where

- D = minimum depth of stiffener in metal other than carbon steel, in millimetres
- d = depth of stiffener for carbon steel, determined in accordance with Clause 4.7.3.6(c)
- UTS_{tank} = ultimate tensile strength of tank material, in megapascals (MPa).

4.7.3.10 FRP non-portable, free-standing fuel tanks—general

Sandwich construction shall not be employed in FRP free-standing fuel tanks. Scantlings for FRP free-standing fuel tanks shall be calculated in accordance with AS 4132.1 and AS 4132.3. Alternatively, the scantlings for FRP free-standing fuel tanks may be determined in accordance with Clauses 4.7.3.11 and 4.7.3.12 below.

4.7.3.11 FRP non-portable, free-standing fuel tanks—basis for scantlings

The scantlings for FRP free-standing fuel tanks in Clause 4.7.3.12 are based on the following minimum requirements for mechanical properties:

- a) Tensile Strength—80 MPa
- b) Bending Strength—120 MPa
- c) Modulus of Elasticity:
 - i) Tensile (E_s)—7000 MPa
 - ii) Bending (E_b)—7000 MPa

NOTE: A mass per square metre of reinforcement material of 430 grams per square metre per millimetre ($\text{g/m}^2/\text{mm}$) of laminate thickness has been assumed.

4.7.3.12 FRP non-portable, free-standing fuel tanks—tank shell laminate and stiffener requirements

The scantlings of the shell laminate and stiffeners for non-portable, free-standing fuel tanks manufactured from FRP shall be in accordance with Table 3 and Table 4 respectively.

Table 3 — Laminate for free-standing fuel tank shell

Depth of Tank (m) ^A	Head (m) ^B			
	1.8	2.4	3.0	3.6
	Laminate Weight (g/m^2) ^C			
0.6 and less	4260	4760	5210	5660
0.9	4540	4980	5430	5825
1.2	4760	5210	5660	6050
1.5	4980	5430	5825	6220
1.8	5210	5660	6050	6380

LEGEND

- ^A The depth of the tank shall be measured from the lowest point of the tank panel to the crown of the tank.
- ^B The head shall be measured from the crown of the tank to the top of the air or overflow pipe, whichever is the greater, but cannot be less than 1.8 m.
- ^C The laminate weights are for stiffeners spaced 460 mm apart. Where the spacing differs from 460 mm, the laminate shall be modified in direct proportion.

Table 4 — Stiffening of free-standing fuel tanks

Length of stiffeners (m)	Minimum head for vertical stiffeners (m) ^A	Head (m)			
		1.8	2.4	3.0	3.6
		Stiffener Section Modulus (cm^3) ^B			
0.9 and less	2.25	17.0	22.5	28.5	34.0
1.2	2.40	30.5	40.5	50.0	59.5
1.5	2.55	46.5	62.5	77.5	92.5
1.8	2.70	67.0	90.0	111.5	134.0

LEGEND

- ^A The head shall be measured from the centre of the span to the top of the air or overflow pipe, whichever is the greater, but shall not be less than the value given in the table for vertical stiffeners, or 1.8 m above the crown of the tank for horizontal stiffeners.
- ^B The modulus values are for stiffeners spaced 460 mm apart. Where the spacing differs from 460 mm, the modulus shall be modified in direct proportion.

4.7.3.13 Internal structure and coatings for non-portable, free-standing fuel tanks constructed of FRP

The minimum laminate for internal baffles in non-portable, free-standing FRP fuel tanks shall not be less than 2400 g/m². A fuel-resistant flow-coat shall be applied to the internal surface, preferably over a heavy resin-rich (2.5:1) chopped strand mat layer using vinyl ester.

4.7.4 Portable fuel tanks

4.7.4.1 Design

Portable fuel tanks shall be designed to minimise the possibility of overturning and facilitate ease of handling and securing against movement.

4.7.4.2 Manufacture

Portable fuel tanks shall comply with the following:

- a) Unless part of the original engine manufacturer's equipment, the tank shall be manufactured from corrosion-resistant metal or shall be coated with a material to provide protection from corrosion.
- b) Where applicable, the tank shall have mated parts that are galvanically compatible.
- c) The tank shall have all service and vent openings above the full contents level.
- d) The tank shall be fitted with a fuel contents gauge.
- e) AS 2906, unless the tank is part of the original equipment as supplied by the engine manufacturer.

NOTE: AS 2906 specifies material, design, properties and marking requirements for refillable, portable fuel tanks of capacity up to 25 L.

4.7.4.3 Location

Where a vessel is fitted with a flush or sealed deck, portable fuel tanks shall be situated above that deck in such a position as to prevent any fuel from draining to spaces below the deck in the event of a spillage.

4.7.4.4 Fuel lines

Fuel lines for portable fuel tanks shall be of heavy-duty synthetic rubber and shall be fitted with bayonet-type fittings at the tank or engine connection which, when disconnected, will automatically shut off fuel from the tank.

4.8 SAFETY ARRANGEMENTS FOR POWER-OPERATED FUEL PUMPS AND MOTORS

4.8.1 Relief valving

If the closed discharge pressure of a cargo oil pump, fuel transfer pump or fuel pressure pump exceeds the maximum design working pressure of the discharge system, a relief valve discharging back to the suction side of the pump shall be fitted.

4.8.2 Stop valves

Stop valves shall be fitted on the suction and discharge lines of cargo oil, fuel transfer and fuel pressure pumps.

4.8.3 Means of stopping

A fuel transfer pump or cargo oil pump shall be fitted with means to stop the pump from both inside and outside the space in which it is located.

The remote fuel transfer pump or cargo oil pump shut-down arrangements shall be capable of operating when exposed to flame and heat from a fire within the space containing the pump.

4.8.4 Fuel filters

Transparent filter casings of plastic or glass shall be resistant to both mechanical impact and thermal shock, and shall either be fitted with guards or located in protected positions.

Where fuel filters are not installed in positions such that any spillage is directed overboard, they shall be designed and installed such that their disassembly will result in minimum spillage.

NOTE: Fuel filters may be fitted at any position in the fuel system after the fuel shut-off valve or cock referred to in Clause 4.7.1.5.

4.9 ADDITIONAL REQUIREMENTS FOR FUEL SYSTEMS IN VESSELS WITH NON-PORTABLE FUEL TANKS AND WHICH OPERATE ON FUEL WITH FLASHPOINT MORE THAN 60°C

Refer to Figure 11.

NOTE: AS 3570 specifies 61.5°C as the minimum flashpoint for diesel. Australian fuels meet the requirements of AS 3570. Some overseas standards specify a temperature less than 60°C for the minimum flashpoint of diesel.

4.9.1 Fire risk

The fuel system of a vessel shall be designed and installed so that failure of any part of the fuel system does not increase the risk of fire to unacceptable levels.

NOTE: Measures to reduce the risk of fire from a failure in the fuel system include separation from potential sources of ignition, sheathing of fuel piping, spray guarding, and the fitting of alarms.

4.9.2 Fuel tank contents measurement

Non-portable fuel tanks shall be fitted with a means for determining the amount of fuel contained in the tank. It shall not be possible for fuel to leak through the measurement device in the event of the tank being overfilled.

Where a level indicating gauge glass is fitted on a non-portable fuel tank, it shall be fitted with self-closing valves or cocks. Where the upper end of the gauge glass is connected to the tank through the top plating, only one such self-closing valve or cock at the lower end need be fitted.

Fuel tank sounding pipes should not terminate in accommodation spaces. Where such sounding pipes terminate in alleyways, flush deck screwed caps should be fitted.

4.9.3 Fuel tank drains

Non-portable fuel tanks shall be fitted with a drain valve or drain cock, the open end of which shall be blanked with a screwed plug. Alternatively, fuel tanks with a capacity less than 400 L may be provided with just a screwed drain plug.

4.9.4 Rigid Fuel piping

Unless provided for in Clause 4.9.5, fuel piping for non-portable fuel tanks shall be of seamless, heavy gauge metal. The piping shall be connected by flanged joints, metal to metal joints of the conical type or other suitable means. Such connections shall be kept to a minimum, and shall be readily visible and accessible.

Where cone nipples are used, they shall be welded. Olive-type compression fittings shall not be used.

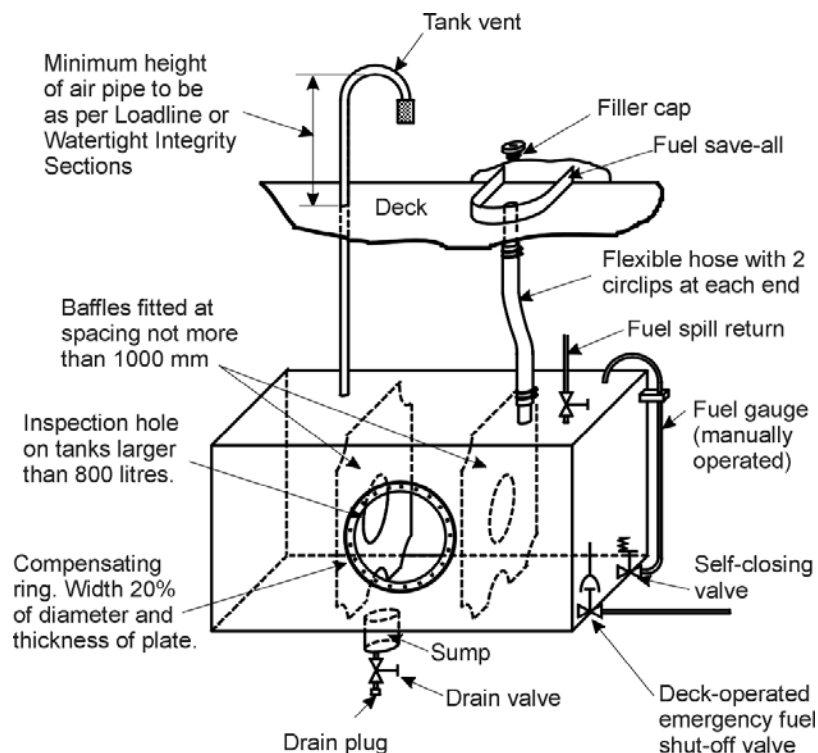

Figure 11 — Example of a freestanding non-portable fuel tank installation for fuel over 60°C flashpoint (informative)

4.9.5 Flexible fuel piping

Flexible fuel piping may be used in fuel systems for non-portable fuel tanks only—

- a) between the fuel shut-off valve or cock specified in Clause 4.7.1.5 and the main or auxiliary engine; and
- b) to conduct any fuel bypass back to the top of the fuel tank.

Flexible piping shall have a synthetic rubber inner tube with metal braided reinforcement. It shall be resistant to heat, salt water, petroleum products and shall be a component supplied for the purpose by the engine manufacturer or shall comply with a relevant national or international standard. It shall be installed so as to be readily visible and clear of the bilge, and shall be secured to prevent chafing. Hose fittings shall be in accordance with the hose manufacturer's recommendations for the particular application. Hose clamps should not be used.

Flexible piping should be located so as to permit regular inspection and periodic replacement.

NOTES:

1. Flexible fuel lines tend to degrade over time.
2. Compliance with relevant national or international standards include classification society approval, approval by a national marine authority (e.g. AMSA, US Coast Guard), certified compliance with a relevant standard (such as SAE 30R9-Fuel Injection Hose Medium-Pressure Coupled and Uncoupled Synthetic Rubber Tube and Cover). Compliance is only valid if the application is the same as that envisaged by the particular standard or authority, especially supply pipes to fuel injection pumps which are subjected to dynamic pulsing. Fuel returns may also be subjected to dynamic pulsing.

4.10 ADDITIONAL REQUIREMENTS FOR FUEL SYSTEMS IN VESSELS WITH NON-PORTABLE FUEL TANKS AND WHICH OPERATE ON FUEL WITH FLASHPOINT LESS THAN 60°C

Refer to Figure 12 and Figure 13.

NOTE: Petrol (gasoline) and liquefied petroleum gas (LPG) both have a flashpoint less than 60°C.

4.10.1 Application

The requirements of this Clause apply to fuel systems in vessels with non-portable fuel tanks and which operate on fuel with a flashpoint less than 60°C, with the exception of liquefied petroleum fuel systems. Liquefied petroleum fuel systems shall comply with Part C Subsection 5D (LPG Systems for Engines) of the NSCV.

4.10.2 Gravity feed fuel systems

Gravity feed fuel systems shall not be used on engines with non-portable fuel tanks of capacity exceeding 10 L.

4.10.3 Fuel tank capacity

Non-portable fuel tanks should be no larger than that necessary for the intended service of the vessel, but should be of sufficient capacity to prevent them having to be filled while in service.

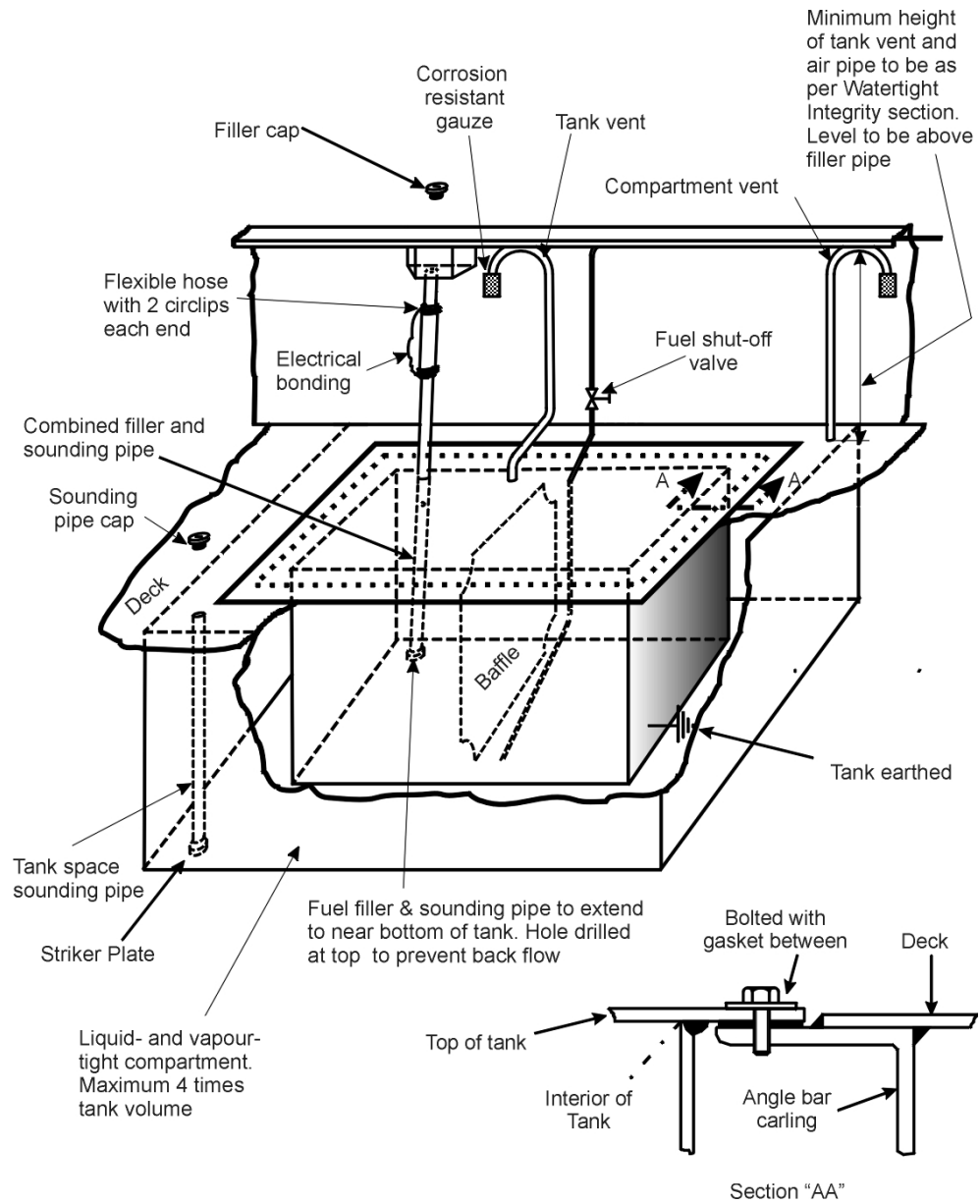

Figure 12 — Example of an under-floor fuel tank installation for fuel less than 60°C flash point (informative)

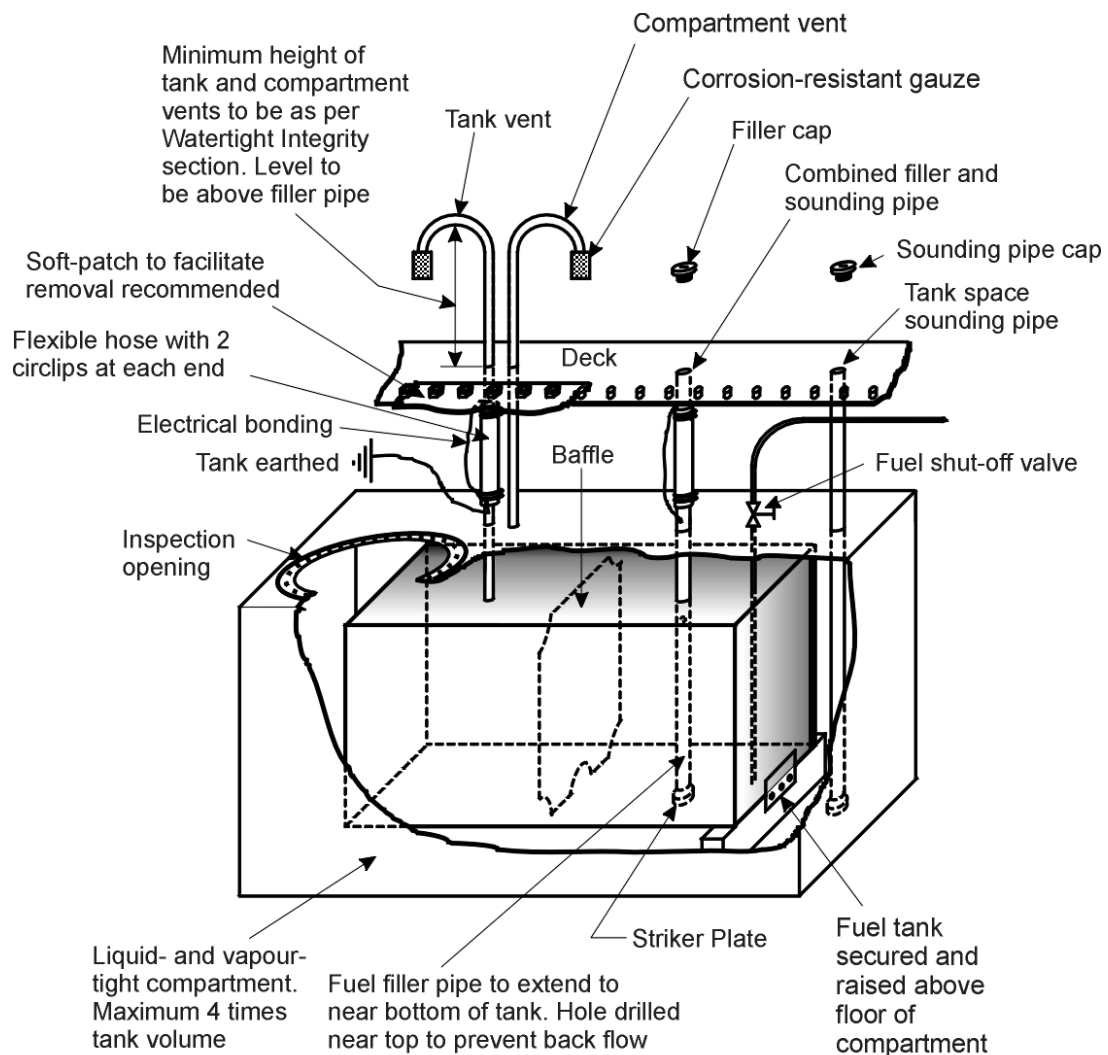

Figure 13 — Alternative example of an under-floor fuel tank installation for fuel less than 60°C flashpoint (informative)

4.10.4 Fuel tank contents measurement

Non-portable fuel tanks shall be fitted with a means for determining the amount of fuel contained in the tank. It shall not be possible for fuel to leak through the measurement device in the event of the tank being overfilled. The cap provided on the sounding pipe for the insertion of the sounding rod shall have a maximum clear opening of 15 mm diameter.

NOTE: The 15 mm limit on caps for sounding pipes is intended to prevent the risk of spillage where a sounding pipe not intended for use as a filling point is used for that purpose. It does not apply where the filling pipe is also designed for taking soundings.

4.10.5 Fuel tank location

Non-portable fuel tanks shall be securely installed in a location remote from the engine, exhaust pipes and other potential sources of ignition.

Fuel tanks located below the deck or within an enclosed space shall be in a compartment no greater than four times the volume of the tanks. The fuel tank compartment shall be liquid and vapour tight to all other compartments.

Such fuel tank compartments shall not be used for any purpose other than for housing the fuel tanks. Means to sound the fuel tank space shall be provided.

NOTE: The likelihood of fuel leaking from a tank is reduced when penetrations such as fuel take-offs, tank vents and inspection covers are arranged to pass through the top of the tank; e.g. refer to Figure 13 and Figure 14.

4.10.6 Fuel filler pipe

The fuel filler pipe for non-portable fuel tanks shall extend to a point close to the bottom of the tank.

NOTE: The purpose of this clause is to reduce the backflow of inflammable vapours through the filling pipe.

4.10.7 Inspection

Non-portable fuel tanks and associated fittings should be able to be inspected externally.

4.10.8 Ventilation

Spaces for non-portable fuel tanks that do not drain overboard shall be adequately ventilated. Venting shall be via a vent pipe to an open space where there is no risk of the escaping vapour igniting or posing any other hazard.

Each fuel tank shall also be fitted with a vent pipe, remote from the tank space vent, leading to a similar open space.

Vent pipes from tank spaces and fuel tanks shall comply with the relevant requirements of Part C Section 2: Watertight and Weathertight Integrity of the NSCV. They shall be separate and non-communicating, and shall be fitted with spark arresters (e.g. wire gauze diaphragms).

NOTE: Additional ventilation of the fuel tank space may be provided by a flameproof fan. Alternatively, a gas detector may be fitted, having an audible or visual alarm located at the control position. Guidance for the fitting of flameproof fans is provided in AS 1799.3 Chapter 5.

4.10.9 Electrical connections

Unless required for establishing the amount of fuel in a non-portable fuel tank, electrical connections or wiring shall not be fitted anywhere within the tank space.

4.10.10 Electrical bonding

Electrical bonding shall be provided to protect against the possibility of a spark arising from static charge causing an explosion. Each non-portable

metallic fuel tank and metal or metal-plated component of the fuel fill system that may come into contact with fuel shall be earthed so that resistance to earth is less than 10 ohms. When a fill or air pipe contains a non-conducting flexible section, a conductor shall join the metallic sections of the fill or air pipe to protect against a static charge arising during fuel filling.

4.10.11 Fuel piping

Unless provided for in Clause 4.10.12, piping in fuel systems for non-portable fuel tanks shall be of seamless heavy gauge metal. Pipe connections shall be made via flanged joints, metal to metal joints of the conical type or other suitable means, and shall be minimised. Pipe connections shall also be readily visible and accessible.

Where cone nipples are used, they shall be welded. Olive-type compression fittings shall not be used.

4.10.12 Flexible piping

A short length of flexible piping may be fitted in fuel systems for non-portable fuel tanks in the section of line between the engine bed and the fuel lift pump.

Flexible piping shall have a synthetic rubber inner tube with metal braided reinforcement. It shall be resistant to heat, salt water, petroleum products and vibration and shall comply with a relevant national or international standard (SAE J 30 or equivalent). It shall be installed so as to be readily visible and clear of the bilge, and shall be secured to prevent chafing.

4.10.13 Carburettor trays

Carburettors in fuel systems for non-portable fuel tanks (other than down-draught type carburettors) that can flood or overflow shall be fitted with a flame trap and a drip tray. The drip tray should—

- a) be made of copper or brass;
- b) be fuel-tight;
- c) have a corrosion-resistant wire gauze screen sweated into it not less than 13 mm below its lip;
- d) be of a size sufficient to impound any leak from the carburettor; and
- e) be readily removable.

4.10.14 Engine covers

Engine covers that might be fitted to protect the engine from the weather or salt spray shall be provided with adequate ventilation to prevent the accumulation of explosive fumes.

CHAPTER 5 FLUID SYSTEMS

5.1 SCOPE

This Chapter specifies requirements for installation and operation of seawater and bilge systems. It applies to vessels of less than 35 m in measured length.

NOTE: For vessels of 35 m or more in measured length, refer to Clause 1.2.1.

5.2 OBJECTIVE

The objective of this Chapter is to control the risks arising from seawater and bilge system installations within the vessel and to provide effective and reliable means for detecting and discharging water that may collect within the vessel.

NOTES:

1. Specific hazards associated with fluid system installations include the following: flooding of the vessel due to a failure of piping, flooding of the vessel due to back-flooding through piping, blockage of piping, inability to pump bilge water from one or more compartments (due to failure of bilge pumps, pipes drawing air or failure of piping), failure to detect flooding.
2. Consequences of these hazards include the following: foundering of the vessel through progressive down-flooding or capsizing, loss of propulsive power, loss of emergency systems.

REQUIRED OUTCOMES

5.3 MEANS FOR MONITORING LIQUID LEVELS

Means must be provided for readily ascertaining the quantity of liquid within any tank or watertight compartment.

5.4 WATERTIGHT INTEGRITY

Seawater and bilge systems must be designed and constructed to maintain the watertight integrity of the hull in normal and abnormal conditions.

Any reference to “sea” or “seawater” in Chapter 5 also applies to vessels operating in freshwater.

5.5 DRAINING OF SPACES WITHIN THE VESSEL

Means must be provided for draining the watertight spaces within a vessel in normal and abnormal conditions to—

- a) maintain the vessel's reserve buoyancy and stability;
- b) prolong the time before the reserve buoyancy or stability is lost;
- c) maintain the function of equipment essential to the safety of persons on board the vessel, or prolong the time before such equipment no longer functions; and
- d) prevent corrosion and degradation caused by moisture lying within the vessel.

5.6 RELIABILITY

Seawater and bilge systems essential to the safety of the vessel must provide a reliable means for fulfilling their specific functions.

DEEMED-TO-SATISFY SOLUTIONS

5.7 DISCHARGES INLETS AND SEAWATER PIPING

5.7.1 Compliance

For the purpose of this National Standard, discharges, inlets and seawater piping within a vessel shall be deemed to have satisfied the Required Outcomes in Clauses 5.4 and 5.6 if they comply with Clauses 5.7.2 to 5.7.4.

5.7.2 Discharge and inlets

5.7.2.1 *Seagoing Class 1 and Class 2 Vessels 24 m and more in measured length*

All discharges, inlets and scuppers on seagoing vessels that are required to be marked with a load line in accordance with Part C Subsection 2A (Watertight and Weathertight Integrity — Loadline Vessels) of the NSCV shall comply with the load line conditions of assignment for discharges, inlets and scuppers contained within that Subsection. Where there is conflict between the provisions of Clause 5.7.2 and those of Part C Subsection 2A, the latter shall prevail.

5.7.2.2 *Inlet and discharge valves*

All sea inlet and overboard discharge pipes (including sanitary discharges) shall be fitted with valves or cocks unless required otherwise by Clauses 5.7.2.3 or 5.7.2.4.

5.7.2.3 *Small discharges*

A small discharge may not be fitted with a valve provided that:

- a) the internal diameter of the discharge does not exceed 50 mm; and
- b) the lowest point of the discharge is not less than 225 mm above the deepest loaded water line.

5.7.2.4 *Scupper discharges*

A scupper discharge which passes through the vessel's side from a space above the bulkhead deck may be fitted with a non-return valve in lieu of a screw-down valve or cock.

5.7.2.5 *Valves and cocks*

Valves and cocks shall be manufactured from bronze, ductile cast steel or equivalent material. Where a valve with a screwed bonnet is a sea injection valve or a valve controlled by an extended spindle, the bonnet shall be secured so that it cannot slacken when the valve is operated.

5.7.2.5.1 *Fitting*

Valves and cocks shall be fitted such that they are readily accessible at all times. They shall be mounted on pads or flanges and secured to one of the following:

- a) The hull of the vessel.
- b) Water boxes.
- c) Standpipes.

Where secured to standpipes, the standpipes shall be as short as practicable.

5.7.2.5.2 *Types*

Valves and cocks with a bore greater than 50 mm shall be of the flanged type. Those with bores 50 mm or less shall either be of the flanged type or the screwed type (see Clause 5.7.2.5.3).

5.7.2.5.3 *Skin fittings and standpipes*

Valves and cocks shall be secured to the hull of the vessel by means of a metallic skin fitting or standpipe. The finished wall thickness of any such stand pipe shall be a minimum 1.25 times the calculated thickness for a hull of the same material as the standpipe.

5.7.2.5.4 *Gratings*

Gratings shall be fitted on the outside of the hull to all seawater inlets. The clear area through the grating shall be at least twice the area of the connected valve. Gratings should be removable to permit access.

5.7.3 **Pipe materials**

5.7.3.1 **General characteristics**

Material for seawater piping shall be suitable for its intended service taking into account the nature of fluid carried and the demands imposed by its location in the vessel. All piping that may come into contact with seawater shall be corrosion-resistant.

NOTE: Other characteristics that are relevant for pipes used for seawater applications include resistance to internal pressure, vacuum and external pressure, axial strength, operating temperature limitations, impact resistance, resistance to fatigue, ageing and erosion, fluid absorption, material compatibility, fire endurance and smoke generation upon combustion.

5.7.3.2 **Metallic piping**

5.7.3.2.1 *Material*

Metallic piping shall be copper, stainless steel, aluminium alloy of a grade suitable for long-term exposure to seawater or carbon steel which has been protected against corrosion (e.g. galvanising).

5.7.3.2.2 *Thickness*

The thickness of metallic piping shall be sufficient to withstand the likely maximum pressure with due allowance for corrosion and erosion that may

occur. In any case, the thickness of metallic piping shall not be less than the following:

$$t_p = 0.012 d_i + t_0$$

where

- t_p = minimum pipe thickness, in millimetres
- d_i = internal diameter, in millimetres
- t_0 = 1.8 mm for carbon steel or aluminium
1.1 mm for copper
0.8 mm for stainless steel or copper alloy.

5.7.3.3 Rigid plastic piping

5.7.3.3.1 Application

Rigid plastic piping shall meet the requirements contained in IMO Resolution A.753(18), or the requirements of a Classification Society.

NOTE: IMO Resolution A.753(18) places limits on the extent to which rigid plastic piping can be used for essential services on board ship. In particular, fire endurance, reliability and the consequences of failure are important considerations.

5.7.3.3.2 Installation

Rigid plastic piping shall be arranged so that it is readily accessible for inspection and protected against mechanical damage and contact with hot surfaces.

Where acrylonitrile butadiene styrene (ABS) piping is used in pressure applications, it shall comply with AS 3518.1. Fittings for ABS piping shall comply with AS 3518.2.

NOTE: Plastic piping has a coefficient of linear expansion that is eight to ten times that of steel. Where plastic piping is used, design requirements over the range of service temperatures will have to be considered.

5.7.3.4 Flexible piping

5.7.3.4.1 General characteristics

Flexible piping shall be reinforced synthetic rubber. It shall comply with a relevant national or international standard and shall have the following performance characteristics:

- a) Resistance to water, petroleum products, heat and vibration.
- b) Capable of operation under suction without collapse and resultant reduction in effective cross-sectional area.
- c) Capable of withstanding internal pressure present within the system.

5.7.3.4.2 Application

Flexible piping shall be readily visible and located so as to prevent mechanical damage and contact with hot surfaces. Subject to Clause 5.8.4.4, flexible piping shall only be used in the following applications:

- a) In short lengths of no more than 760 mm for vibration damping or to accommodate relative movement of machinery.

- b) In vessels less than 12.5 m in length, provided that—
 - i) the length of piping does not exceed half the beam of the vessel;
 - ii) the run of the piping is as direct as practicable; and
 - iii) it is adequately supported.

5.7.3.4.3 Method of securing

The method of securing flexible piping to a rigid pipe or fitting shall be appropriate for the nature of fluid carried and the risks associated with leakage of that fluid.

Where clips are used to secure flexible piping of 25 mm internal diameter and above, at least two such clips shall be fitted at each end of the flexible pipe and the clips shall be of corrosion-resistant material.

5.7.3.5 Pipe fittings—material

Pipe fittings shall not be made of malleable iron.

5.7.4 Fish tank pumping systems

5.7.4.1 Piping for filling or discharging fish cargo tanks

Non-metallic piping may be used for filling or discharging fish cargo tanks provided that—

- a) the piping complies with Clause 5.7.3.3;
- b) bilge alarms are fitted in each compartment in which the piping is installed; and
- c) any penetration by the piping of a high fire risk space bulkhead, including the bulkhead of a machinery space, is via a valve.

5.7.4.2 Valves for fish tank pumping systems

A valve shall be provided at each connection to a fish tank. The valves shall either be readily accessible, or where not readily accessible the valves shall either be capable of being readily closed from a position above the bulkhead deck, or shall be non-return valves.

NOTE: Valves need not be provided on the pipe connections to a fish tank if a rupture of the pipe would not reduce the safety of the vessel. Factors to be considered include the effect of discharging the tank contents into the bilge of the vessel and the effect of the ruptured pipe on the vessel's weathertight integrity.

5.8 BILGE PUMPING SYSTEMS

5.8.1 Compliance

For the purpose of this National Standard, the means for draining of spaces within the vessel shall be deemed to have satisfied the Required Outcomes in Clauses 5.3 and 5.6 if it complies with Clauses 5.8.2 to 5.8.9.

5.8.2 General

5.8.2.1 Capability of bilge pumping system

Unless otherwise provided for in Clauses 5.8.2.2 or 5.8.2.3, a vessel shall be fitted with a pumping system capable of pumping from and draining any bilge or watertight compartment in the vessel.

NOTE: Australia is a party to MARPOL Annex 1. The discharge of oil or other pollutants (including oily bilge water) overboard may be subject to Commonwealth, State or Territory marine pollution legislation. For bilge systems, this may necessitate the fitting of oily bilge water holding tanks or oil separation equipment.

5.8.2.2 Alternative arrangements for small open vessels

Open vessels of measured length less than 5 m may be provided with a bailing bucket in lieu of a bilge system, provided there is ready access to the bilge for bailing.

5.8.2.3 Alternative arrangements for small compartments

A watertight compartment less than 7 per cent of the total under deck volume may be drained into an adjacent compartment by means of a self-closing valve or cock. The adjacent compartment shall itself be served by the bilge system. The valve or cock shall be fitted outside the compartment to be drained, and shall be operable from a readily accessible position.

NOTE: Other bilge pumping arrangements for small compartments are possible but would need to be considered as equivalent solutions (see Part B—General Requirements of the NSCV). For example, bilge pumping arrangements may not be needed on small vessels having numerous small compartments where it can be shown that the safety of the vessel is not materially reduced by the flooding of adjacent compartments. Key factors would include: the effectiveness of watertight boundaries; the flooded characteristics of the vessel; the effect on systems essential to the safety of the vessel; means for monitoring water levels within compartments; and arrangements to remove accumulated water in the bilge.

5.8.2.4 Location of bilge suction

Bilge suction shall be located to facilitate the drainage of water from within each compartment over a range of list not less than $\pm 5^\circ$. Limber holes or other arrangements shall be provided to allow water to drain past structural members to the bilge suction.

NOTE: Bilge suction are normally located at the lowest point of a compartment or, where no lowest point can be identified, at the after end of the compartment. More than one suction is normally provided in long compartments and on vessels with a flat bottom (rise of floor less than 5°), arranged so as to ensure the bilge pump will not lose suction in the event of one suction drawing air.

5.8.2.5 Back-flooding

The bilge system shall be arranged to prevent water back-flooding from the sea into watertight compartments or machinery. The bilge connection to any pump that also draws from the sea shall be either a screw down non-return valve, or a cock that cannot be opened at the same time to the bilge and to the sea.

5.8.2.6 Watertight integrity of compartments

The bilge system shall also be arranged to prevent water passing from a flooded watertight compartment into other compartments. Bilge pipes should be located a distance of at least 20 per cent of the breadth of the vessel inboard of the vessel sides to avoid damage in the event of a collision. Alternatively, bilge suction pipes may be provided with non-return valves or foot valves fitted within the space they serve.

5.8.2.7 Bilge distribution manifold

The bilge system in vessels of 25 m measured length and over shall be provided with a bilge distribution manifold located in an accessible position. Valves in bilge distribution manifolds shall be of non-return type.

NOTE: Various configurations may be used for bilge systems. A bilge system may have branch suction pipes from each compartment running to a centrally located bilge distribution manifold. Alternatively the branch suction lines may run into a main bilge line, which in turn passes through compartments to connect with the bilge pumps. In general, the former is recommended, and is required on larger vessels, because it allows for better control and monitoring of the bilge system.

5.8.2.8 Class 1B vessels of 15 m and over

In Class 1B vessels of 15 m in measured length and over, the bilge system shall permit pumping and draining from every space in the vessel while any one watertight compartment is flooded. This provision need not apply to flooding of the machinery space.

NOTE: This may necessitate the fitting of a bilge distribution manifold on vessels less than 25 m in measured length or the remote operation of bilge valves within compartments from a level above the bulkhead deck. While not mandatory, the locating of the two bilge pumps in two separate compartments is recommended.

5.8.3 Bilge pumps**5.8.3.1 Number and capacity of pumps**

Vessels shall be provided with bilge pumps in accordance with Table 5.

Table 5 — Bilge pump requirements

Measured length of vessel (m)	Manual pumps		Powered pumps	
	Qty	Capacity per pump, as installed, in kL/h	Qty	Capacity per pump, as installed, in kL/h
Less than 7.5	1	4.0	N/A	N/A
7.5 and over but less than 10	2	4.0	N/A	N/A
10 and over but less than 12.5	1	5.5	1	5.5
12.5 and over but less than 17.5	1	5.5	1	11.0
17.5 and over but less than 20	1	8.0	1	11.0
20 and over but less than 25	N/A	N/A	2	11.0
25 and over but less than 35	N/A	N/A	2	15.0

NOTE: The installed capacity of a bilge pump is normally less than the nominal figure specified by the manufacturer due to the head of the discharge above the suction and losses through valves and piping.

5.8.3.2 Bilge pumping arrangements—general

The following bilge pumping arrangements apply to vessels fitted with pumps in accordance with Clause 5.8.3.1:

- a) A powered bilge pump may be substituted for a manually operated pump.

- b) A bilge pump shall be self-priming or shall be provided with a priming device.
- c) A powered bilge pump shall be driven by a main engine, an auxiliary engine or a low or medium-voltage electric motor.
- d) Bilge pumps may be fitted additional to those specified in Table 5 provided the pump together with its piping and electrical systems are arranged to ensure that the safety of the vessel is maintained.

NOTE: Sub-clause d) above applies to any extra-low voltage bilge pumps (under 50 V d.c) that may be fitted on a vessel.

5.8.3.3 Bilge pumping arrangements—vessels required to have two pumps

Where two pumps are required, the following shall apply:

- a) Each power pump shall not be dependent on the same source of power.
- b) The pumps and piping systems shall be arranged to enable simultaneous pumping of each machinery space bilge by both pumps on all vessels of 20 m and more in measured length.
- c) If both pumps are powered, the capacity of one pump may be less than that specified in Clause 5.8.3.1 by up to 20 per cent provided the total required pumping capacity is achieved.
- d) For vessels other than Class A, one of the two pumps may be a portable pump provided it can be operated at full capacity within 5 minutes of flooding becoming known. Where a portable pump is fitted, the portable pump and its attachments shall be of a type suitable for connection and operation over the range of conditions likely to be encountered by the vessel in normal and abnormal conditions. A means (e.g. lanyards) shall be provided for securing the portable pump when operating or when being relocated on vessels of Classes B, C or D.

5.8.4 Bilge piping

5.8.4.1 Materials

Bilge piping shall comply with the requirements of Clause 5.7.3.

5.8.4.2 Protection from mechanical damage

Bilge piping shall be protected from mechanical damage arising from the stowage or working of cargo and stores or from other causes.

5.8.4.3 Rigid plastic bilge piping—application

Rigid plastic bilge piping may only be used as follows:

- a) *Vessels less than 12.5 m in measured length*

In any location except where rigid plastic bilge piping passes through spaces which are high fire risk on vessels relying on subdivision unless the watertight integrity of adjacent bulkheads can be maintained by fitting the affected bilge suction pipes with non-return valves.

b) *Vessels 12.5 m and more in measured length*

In low fire risk spaces such as voids, cofferdams and water tanks. The application of rigid plastic bilge piping in other locations shall be subject to meeting the fire endurance requirements contained in IMO Resolution A 753(18) or the requirements of a Classification Society.

NOTE: Alternative arrangements may be acceptable where part of the bilge system is duplicated.

5.8.4.4 Flexible suction hose bilge systems (wandering hoses)

A flexible suction hose bilge pumping system may be fitted to service compartments in Class C, D or E vessels of measured length less than 12.5 metres. Subject to Clause 5.8.3.3 d), the pump or pumps shall be permanently mounted. The hose shall be of sufficient strength not to kink or collapse under suction. Compartments that are not void shall be fitted with a deck-mounted camlock fitting connected to a permanent bilge suction pipe within the compartment.

Where there is a risk of downflooding if hatches or other weathertight or watertight covers leading to a void compartment are opened, void compartments should also be provided with a deck-mounted camlock fitting connected to a suction pipe permanently mounted within the compartment.

5.8.5 Bilge pipe sizes

5.8.5.1 Vessels under 10 m in measured length

The minimum diameter of bilge piping in vessels less than 10 m in measured length shall not be less than 25 mm.

5.8.5.2 Vessels of 10 m measured length and over

The minimum diameters of bilge suction pipes in vessels of 10 m and over in measured length, which shall in no case be less than 32 mm, shall be determined by the following formulas:

- a) For main bilge suction pipes (pipes serving more than one compartment)—

$$d_m = 25 + 1.68\sqrt{L(B+D)}$$

- b) For branch suction pipes (pipes serving just a single compartment)—

$$d_b = 25 + 2.16\sqrt{C(B+D)}$$

where

d_m = internal diameter of the main bilge suction pipe, in millimetres

d_b = internal diameter of branch suction pipes, in millimetres, but not greater than d_m

L = the measured length of the vessel, in metres

B_H = the applicable breadth, in metres, as follows—

- a) for mono-hulled vessels, the breadth of the vessel

- b) For multi-hulled vessels—
 - i) For the main bilge suction pipe in the case of multi-hulled vessels having only a single main bilge line, the sum of the breadths of the hulls;
 - ii) for the main bilge suction pipe in the case of a multi-hulled vessels having a dedicated main bilge line in each hull, the breadth of the applicable hull; or
 - iii) for branch section lines, the breadth of the applicable hull.

D = depth of vessel, in metres

C = length of compartment, in metres.

5.8.6 Strainers

5.8.6.1 Vessels of 20 m in measured length and over

All bilge suction shall be fitted with a mudbox, strum box or strainer that is accessible for cleaning. Each bilge suction in a machinery space shall be fitted with a mudbox and metallic tail pipe.

5.8.6.2 Strainer holes

Strainer holes shall not be greater than 10 mm in diameter, and the aggregate area of the holes shall not be less than twice the area of the suction pipe.

5.8.7 Bilge level alarms

On decked vessels, a bilge level alarm shall be fitted—

- a) in the propulsion machinery space; and
- b) in all other compartments that contain seawater pumping systems.

The alarm shall be clearly audible at a continuously manned control position with the machinery operating under full power conditions.

NOTE: Additional bilge alarms may be required on certain vessels, see Clauses 2.19.9.6 and 5.7.4.1.

5.8.7.1 Power supply

The power supply for the bilge level alarm shall be available at all times there is a person on board.

5.8.8 Collision bulkhead piping

Where a pipe pierces a collision bulkhead, it shall be fitted with a suitable valve or cock at the bulkhead. The control mechanism for the valve or cock shall incorporate a means to indicate clearly whether the valve or cock is open or closed.

5.8.8.1 Means of control

Unless otherwise provided for in Clause 5.8.8.2, the valve or cock shall be controllable from the bulkhead deck.

5.8.8.2 Location and accessibility of collision bulkhead valve

Where the valve or cock is fitted on the after side of the bulkhead and is readily accessible at all times, it need not be controllable from the bulkhead deck.

NOTE: See Clause 5.8.2.3.

5.8.9 Sounding arrangements**5.8.9.1 Means of sounding required**

Sounding pipes or other means of readily determining the amount of liquid shall be provided for—

- a) any tank or watertight compartment that is not part of a machinery space, including a cofferdam and a double bottom tank; and
- b) any cofferdam or double bottom tank that is located in a machinery space.

5.8.9.2 Sounding pipes

Where a sounding pipe is fitted it shall comply with the following:

- a) If located outside of a machinery space, extend to a readily accessible position on deck.
- b) If located in a machinery space, extend either—
 - i) to a readily accessible position on deck; or
 - ii) to a lesser height provided the pipe is fitted with a cock (or ball valve) arranged for automatic closure when released. Cocks for such applications shall be of parallel plug type to provide ready movement. Handles shall be weighted or spring loaded and permanently secured.
- c) Terminate in such a position that there is no risk of overflow spillage onto hot surfaces or electrical equipment.
- d) Incorporate a means of closing to prevent the free entry of water.
- e) Wherever possible be straight, but if curved to suit the shape of the vessel, the curvature shall be sufficient to permit the passage of a sounding rod or a sounding chain.
- f) Be protected against mechanical damage and, where it passes through refrigerated space, shall be thermally insulated.
- g) Be fitted with a striking plate under the lower end of a sounding pipe.
- h) Be of thickness not less than that determined in accordance with Clause 5.7.3.2.2.
- i) Be not less than 32 mm internal diameter.

CHAPTER 6 STEERING SYSTEMS

6.1 SCOPE

This Chapter specifies requirements for steering systems. It applies to vessels of less than 35 m in measured length.

NOTE: For vessels of 35 m or more in measured length, refer to Clause 1.2.1.

6.2 OBJECTIVE

The objective of this Chapter is to control the risks associated with the steering system or a failure of the steering system.

NOTES:

1. Specific hazards associated with the steering system include the following: poor steering system performance, inadequate feedback on steering orientation, contact with the propeller or hull, loss of watertight integrity.
2. Specific hazards that may lead to failure of the steering system include the following: rupture or yield, rudder (or nozzle) sole piece or components; fatigue failure of rudder stock, rudder (or nozzle) or components; seizure of rudder (or nozzle) bearings, failure of the steering actuator.
3. Consequences of these hazards include the following: inadequate responsiveness or loss of vessel control in critical situations causing collision or grounding, flooding of the vessel, inability to return to shelter.

REQUIRED OUTCOMES

6.3 DIRECTIONAL CONTROL

The steering system must be capable of reliably altering the vessel's heading at a rate appropriate for the navigational hazards that might be expected in normal and abnormal conditions. The steering system must also be capable of reliably holding or returning the vessel's head to a given course to counteract the effects of wind, current and waves.

6.4 STRENGTH

The rudder, steering nozzle or other directional control device must have sufficient strength to meet the demands of service in both ahead and astern operation, and in normal and emergency situations. Consideration must be given to peak, fatigue and shock loading.

6.5 CORROSION AND EROSION

The rudder, steering nozzle or other directional control device must be designed and constructed to avoid or reduce the effects of corrosion and erosion.

NOTE: Erosion is caused by operation adjacent to a propeller or other propulsive device.

DEEMED-TO-SATISFY SOLUTIONS

6.6 COMPLIANCE

For the purpose of this National Standard, the steering system shall be deemed to have satisfied the Required Outcomes in Clauses 6.3 to 6.5 if it complies with Clauses 6.7 to 6.11.

6.7 GENERAL STEERING DESIGN CRITERIA

6.7.1 Strength of steering gear

The steering gear shall be designed to withstand maximum helm at maximum ahead and astern speed. The rudderstock, rudder or steering nozzle and tiller arm or quadrant shall comply with Clauses 6.8, 6.9, 6.10 and 6.11 below.

6.7.2 Steering arrangement

The steering arrangement shall be such that the person at the helm has a clear view ahead while at the normal steering position.

NOTE: See also Part C Section 1: Arrangement, Accommodation and Personal Safety) of the NSCV.

6.7.3 Secondary means of steering

All vessels, except twin screw vessels, shall be fitted with two independent means of steering unless steering is normally achieved via a hand tiller, in which case a second means of steering need not be provided. The secondary or emergency means of steering shall be capable of being brought speedily into action.

6.7.4 Rudder movement

Rudder movement shall be no less than 35° to port to 35° to starboard.

NOTE: The formulas specified in Clauses 6.8, 6.9 and 6.11 are based on helm angles not exceeding 35°. Rudder movement in excess of 35° will require a change in the minimum diameter of the rudderstock and the scantlings of the rudder and tiller arm or quadrant.

6.7.5 Performance

In vessels of 12.5 m measured length and over, the steering gear shall be capable of putting the rudder over from 35° on one side to 30° on the other in 30 seconds when the vessel is at maximum ahead service speed with the rudder totally submerged. It shall be designed to prevent violent recoil of the steering wheel.

6.7.6 Helm movement direction

The trailing edge of a rudder blade of a vessel shall move in the same direction as the top spokes of the steering wheel. Where any vessel is not fitted with a conventional steering wheel, movement of the helm actuator to port or starboard shall cause the ship's head to move in the same direction.

6.7.7 Rudder position indicator

A rudder position indicator shall be fitted on all vessels of 15 m measured length and over which are fitted with power-operated steering gear. The rudder position indicator shall be in full view of the person at the helm while the person is at any steering position. This latter requirement need not apply to a person at the helm at the emergency steering position.

6.7.8 Steering component material

Components that transmit torque, tensile stresses or shock loads, including the tiller or quadrant, shall not be manufactured from ordinary grades of cast iron or other non-ductile material.

6.7.9 Hydraulic steering systems

Hydraulic steering systems shall comply with the following requirements:

- a) Means shall be provided to facilitate a quick change over from the primary to the secondary steering.
- b) A relief valve shall be installed in hydraulic systems that incorporate a power pump. The relief valve shall be set to prevent mechanical damage to the steering gear.
- c) Hydraulic hose and piping shall comply with Clauses 7.9.4 and 7.9.5 and shall be located and arranged to minimise the possibility of mechanical, fire or other damage.

NOTE: Mechanical damage includes chafing, crushing and holing.

6.7.10 Mechanical transmission or actuator shaft bearings

Steering transmission or actuator shafts shall be adequately supported in bearings spaced apart not more than 70 times the diameter of the shaft. Bearing spacing adjacent to sprockets or gears shall be such that no undue bending load can be applied to the shaft.

6.8 RUDDER STOCKS

6.8.1 Definitions

For the purposes of this Chapter, the following definitions apply:

Balanced rudder—

a rudder having blade area forward of the rudder stock or pintles (see Figure 14 and Figure 15).

Unbalanced rudder—

a rudder having no blade area forward of the rudder stock or pintles (see Figure 16).

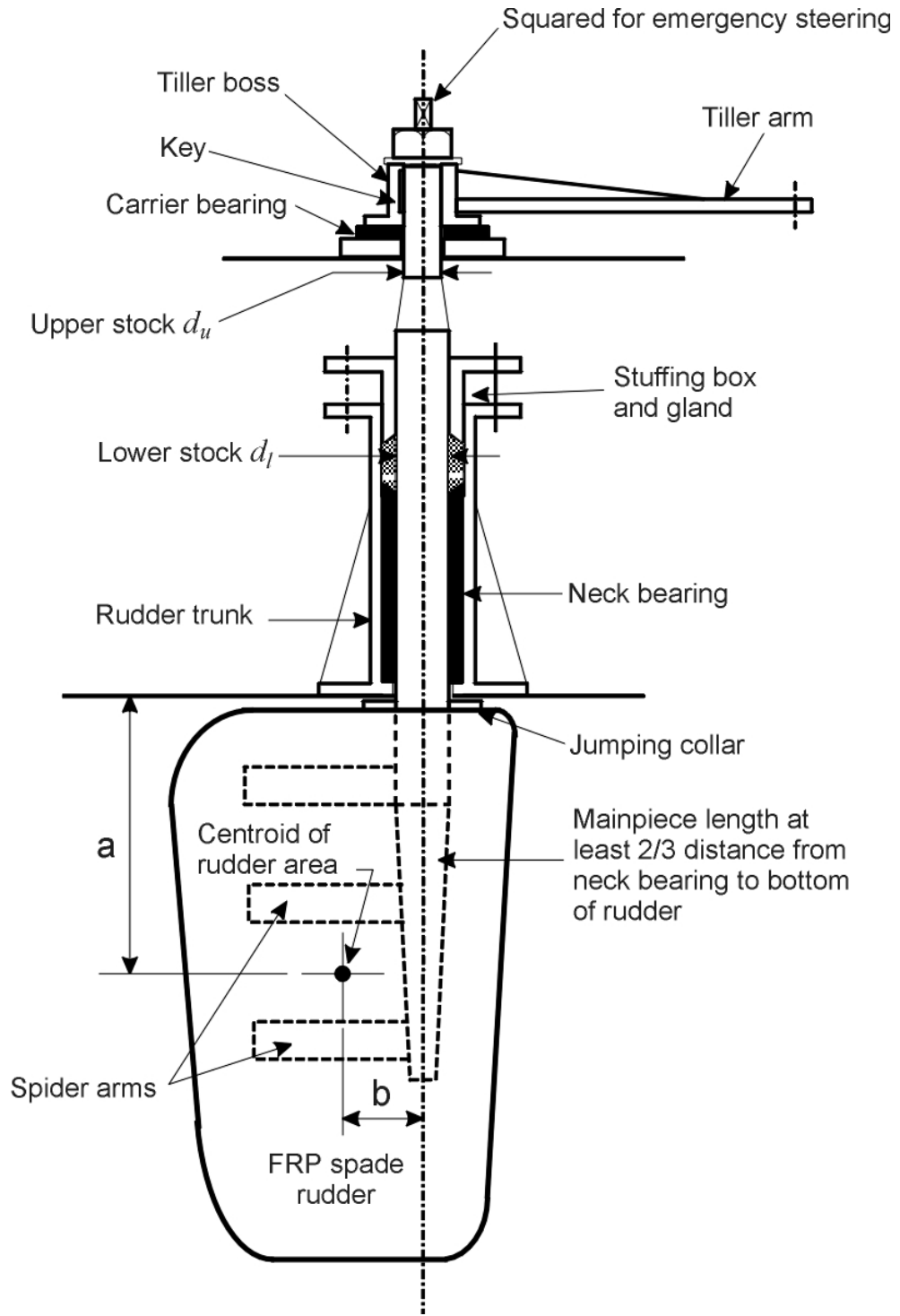

Figure 14 — Balanced spade rudder of FRP construction

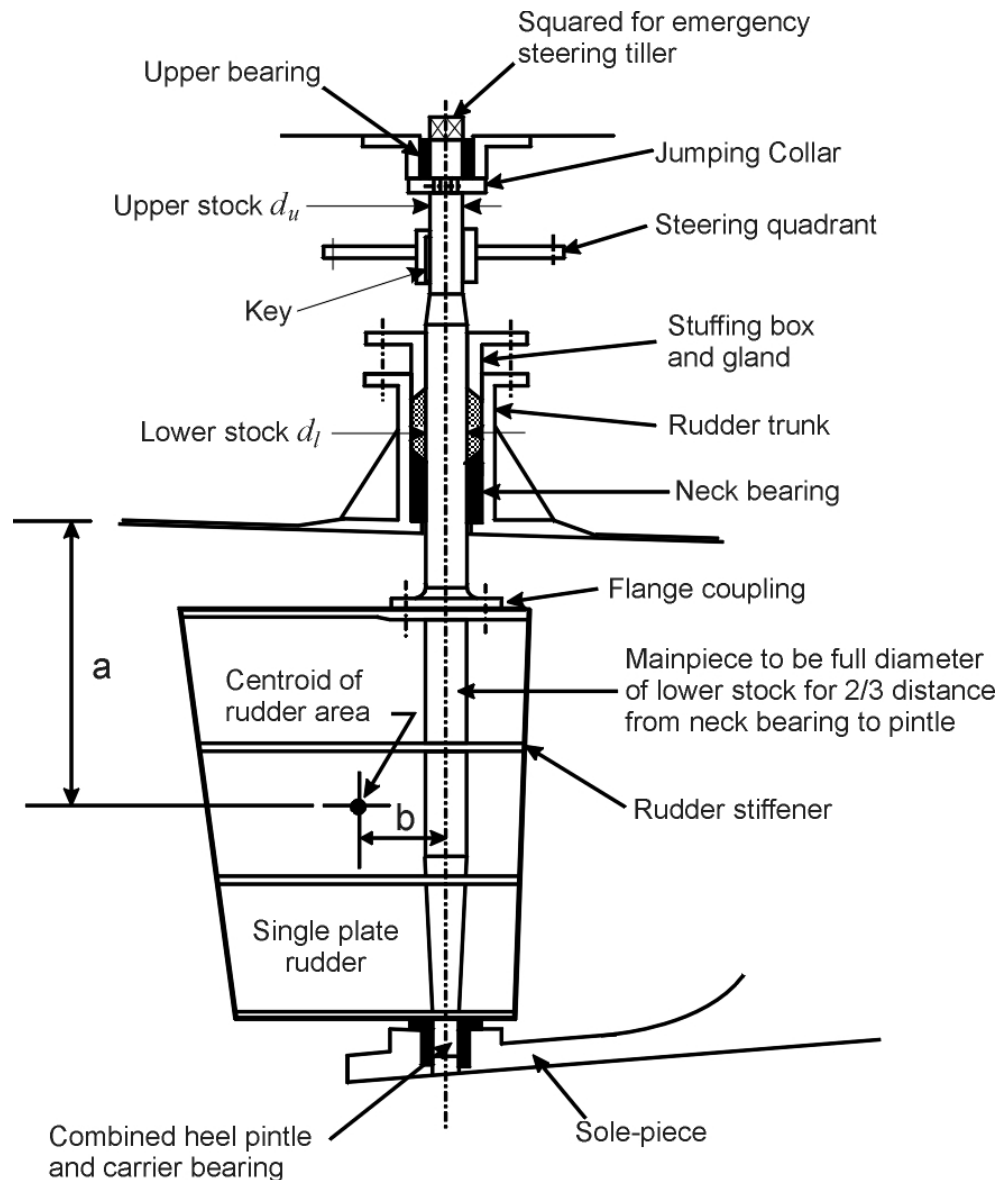

Figure 15 — Balanced rudder of single plate construction

6.8.2 Manufacture

Rudders shall be manufactured in accordance with one of the following methods, or by a means that can be demonstrated to be equivalent:

- a) The rudder blade shall be fabricated or cast, and shall incorporate either an integral flange that is secured to a flanged rudder stock with fitted bolts or shall be secured by means of a taper, key and retaining nut.
- b) The rudder blade shall be fabricated with an integral rudder stock.

NOTE: Special attention should be given to the attachment of the rudder stiffeners, pintles and rudder coupling to the main-piece of the rudder.

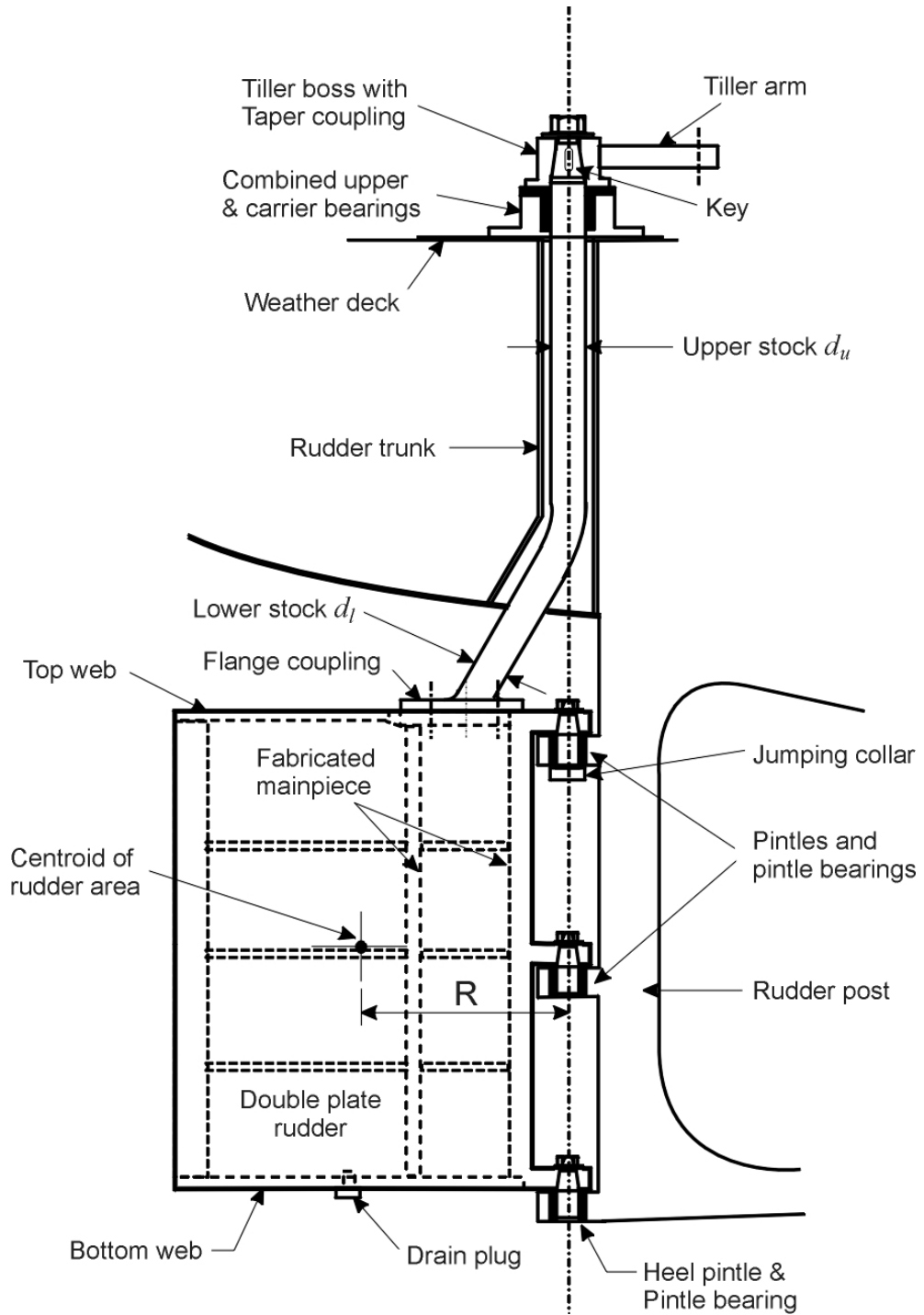

Figure 16 — Unbalanced rudder of double plate construction

6.8.3 Component materials

Unless otherwise permitted in this Chapter the following shall apply:

- a) Rudder stocks, couplings, coupling bolts, pintles and similar parts subject to dynamic stress shall be manufactured from materials having minimum mechanical properties as specified for shaft materials in Clause 3.10.1. Other materials may be used where equivalence can be demonstrated.
- b) Rudder plating and stiffeners shall be of material complying with the requirements specified for hull material in Part C Section 3: Construction of the NSCV.
- c) Cast rudder blades shall be manufactured from ductile material.

NOTE: Most of the formulae for rudder components contained within this Chapter are based on “minimum required” rather than “as fitted” diameters in order to give minimum scantlings. Designing to the minimum required diameter may limit future flexibility in regard to rudder modification or alterations to the vessel which result in an increase in speed.

6.8.4 Rudder stock and main-piece—unbalanced rudders

6.8.4.1 Arrangement of bearings

For the purposes of this Clause, unbalanced rudders are assumed to have at least one pintle (at the heel) with a neck bearing, or additional pintles, or both a neck bearing and additional pintles.

6.8.4.2 Upper stock size

A rudder stock at the tiller or quadrant for an unbalanced rudder shall not be less than that obtained from the following formula:

$$d_u = f_C f_N C \sqrt[3]{\frac{410 R A V^2}{UTS_{stock}}}$$

where

- | | | |
|---------------|---|---|
| d_u | = | minimum diameter of upper stock, in millimetres |
| R | = | distance from the centre line of stock to the centre of area of the rudder (see Figure 16), in metres |
| A | = | area of rudder, in square metres (m ²) |
| V | = | speed of vessel in knots with— |
| | | a) a minimum of 8 in vessels less than 30 m in measured length; and |
| | | b) a minimum of 9 in vessels of 30 m in measured length and over. |
| UTS_{stock} | = | ultimate tensile strength of stock material, in megapascals (MPa) |
| C | = | the coefficient obtained from Table 6. |

- f_C = rudder cross-section coefficient—
- 1 for normal cross-section rudders
 - 1.08 for hollow cross-section rudders; e.g. whale-tail
 - 1.19 for high lift rudders with active trailing edge
- f_N = nozzle coefficient—
- 1 for rudders behind an open propeller
 - 1.09 for rudders behind a propeller in a fixed nozzle.

Table 6 — Values of coefficient C for varying vessel speed V

V (knots)	8	9	10	11	12	13	14	15 and over
C (Measured length of vessel less than 30 m)	21.66	21.25	20.84	20.43	20.02	19.61	19.20	19.20
C (Measured length of vessel 30 m and over)	N/A	21.66	21.25	20.84	20.43	20.02	19.61	19.20

NOTE: Values of coefficient C for vessel speeds between those shown in the table may be obtained by applying the formulas $C = 24.94 - 0.41V$ for vessels of measured length less than 30 m (and speed up to 14 knots) and $C = 25.35 - 0.41V$ for vessels of measured length 30 m and over.

6.8.4.3 Lower stock size

The minimum required diameter of the lower stock d_l above the top pintle or in way of the neck bearing of an unbalanced rudder shall be the same as the minimum required diameter of the upper stock d_u .

6.8.4.4 Mainpiece size

The mainpiece of an unbalanced rudder may be gradually reduced from the minimum required diameter of the lower stock at the top of the rudder blade d_l (as calculated in Clause 0) to $0.75 d_l$ at the heel pintle.

6.8.5 Rudder stock and mainpiece — balanced rudders

6.8.5.1 Upper stock size

A rudder stock above the neck bearing for a balanced rudder shall not be less than that obtained from the following formula:

$$d_u = f_C f_N C \sqrt[3]{\frac{410 b A V^2}{UTS_{stock}}}$$

where

- d_u = minimum diameter of upper stock, in millimetres
- b = horizontal distance, in metres, from the centre of the lower stock to the centre of area of total rudder area (see Figure 14 or Figure 15).
- A = area of rudder, in square metres (m²)
- V = speed of vessel in knots with—
- a minimum of 8 knots in vessels less than 30 m in measured length; and
 - a minimum of 9 knots in vessels of 30 m in measured length and over.
- UTS_{stock} = ultimate tensile strength of stock material, in megapascals (MPa)
- C = the coefficient obtained from Table 6
- f_C = rudder cross-section coefficient—
- 1 for normal cross-section rudders
 - 1.08 for hollow cross-section rudders; e.g. whale-tail
 - 1.19 for high lift rudders with active trailing edge
- f_N = nozzle coefficient—
- 1 for rudders behind an open propeller
 - 1.09 for rudders behind a propeller in a fixed nozzle.

6.8.5.2 Lower stock size

The stock in way of and below the neck bearing for a balanced rudder shall have a diameter not less than that determined from the following formula:

$$d_l = f_C f_N C \sqrt[3]{\frac{410 R A V^2}{UTS_{stock}}}$$

where

- d_l = minimum diameter of lower stock, in millimetres
- R = $0.25 \left(a + \sqrt{a^2 + 16b^2} \right)$ for rudders fitted with neck and heel pintle bearings; or
 $a + \sqrt{a^2 + b^2}$ for rudders not fitted with a heel pintle bearing.

where (from Figure 14 and Figure 15)

- a = vertical distance, in metres, from the bottom of the neck bearing to the centre of area of total rudder area; and

- b = horizontal distance, in metres, from the centre of the lower stock to the centre of area of total rudder area.
- A = total area of rudder, in square metres (m^2)
- V = speed of vessel in knots with—
- a minimum of 8 in vessels less than 30 m in measured length; and
 - a minimum of 9 in vessels of 30 m in measured length and over.
- UTS_{stock} = ultimate tensile strength of stock material, in megapascals (MPa)
- C = the coefficient determined in accordance with either Item a) or b) as follows:
- Where the speed of the vessel is not greater than $4\sqrt{LWL}$ (LWL being the measured length of the vessel, in metres, at the designed waterline), the value of C shall be obtained from Table 6.
 - Where the speed of the vessel is greater than $4\sqrt{LWL}$ (LWL being the length of the vessel in m at the designed waterline), the value of C shall be 16.
- f_c = rudder cross-section coefficient—
- 1 for normal cross-section rudders
 - 1.08 for hollow cross-section rudders; e.g. whale-tail
 - 1.19 for high lift rudders with active trailing edge
- f_N = nozzle coefficient—
- 1 for rudders behind an open propeller
 - 1.09 for rudders behind a propeller in a fixed nozzle.

6.8.5.3 **Mainpiece size (with heel pintle bearing)**

The mainpiece of a balanced rudder having neck and heel pintle bearings (see Figure 15) shall be the full diameter of the lower stock d_l for at least two-thirds of the distance from the neck bearing to the heel pintle bearing. The diameter may be gradually reduced below this point to $0.75d_l$ at the heel pintle.

6.8.5.4 **Stock and mainpiece size (no heel pintle bearing)**

The stock and mainpiece of a balanced spade rudder that has no heel pintle bearing (Figure 14) shall be the required diameter of the lower stock d_l from the neck bearing to the underside of the top rudder arm if a single plate rudder, or to the top of the rudder if a built-up rudder. The diameter of the mainpiece may be gradually reduced below this point until it is $0.5d_l$. The length of mainpiece in way of the rudder shall not be less than two-

thirds of the depth of the rudder at the centre line of the stock. The stock above the neck bearing may be gradually reduced from the required diameter of the lower stock d_l to the required diameter of the upper stock d_u at a point just below the upper bearing.

6.8.6 Non-circular sections

The width, depth, section modulus and torsional modulus of a mainpiece or stock of non-circular section shall not be less than those required for a circular mainpiece or stock. When calculating the section modulus of the mainpiece, the effective width of plating that may be included on each side of a web forming the mainpiece shall not be greater than the thickness of the rudder at the centre line of the stock. Where the material of the mainpiece differs from that of the stock, the section modulus of the mainpiece shall not be less than that determined from the following formula:

$$Z_{mpiece} = \frac{\pi d_l^3}{32000} \left(\frac{UTS_{stock}}{UTS_{mpiece}} \right)$$

where

Z_{mpiece} = minimum section modulus of mainpiece at the top of the rudder, in cubic centimetres (cm³)

d_l = required diameter of the mainpiece, in millimetres, as determined in Clauses 6.8.4.4, 6.8.5.3 or 6.8.5.4

UTS_{stock} = ultimate tensile strength of stock material, in megapascals (MPa)

UTS_{mpiece} = ultimate tensile strength of mainpiece material, in megapascals (MPa).

6.8.7 Rudder bearings, pintles, gland and stops

6.8.7.1 Rudder support

Rudder bearings shall be adequately supported, and their housings shall be rigidly attached to the vessel's structure.

The weight of a rudder shall be supported at a pintle bearing (normally the heel pintle) or a carrier bearing. The structure in way of the pintle or carrier bearing shall be strengthened for that purpose.

6.8.7.2 Sole-pieces

6.8.7.2.1 Ratio of width to depth

For the purposes of the formulas contained in Clauses 6.8.7.2.2 to 6.8.7.2.4, the width to depth ratio of a sole-piece shall not be greater than 2.3 to 1 nor less than 1.8 to 1.

6.8.7.2.2 Section modulus

The section modulus of the sole-piece about the vertical axis at a distance l_s from the centreline of the rudder stock shall not be less than that determined from the following formula:

$$Z_S = C_S AV^2 l_S f_C \left(\frac{410}{UTS_S} \right)$$

where

Z_S = required section modulus of the sole-piece about the vertical axis, in cubic centimetres (cm³)

C_S = a coefficient varying with speed obtained from Table 7

A = total area of rudder, in square metres (m²)

V = maximum speed of vessel, in knots

l_S = horizontal distance from the centreline of rudder stock to the particular section of the sole-piece, in millimetres

UTS_S = ultimate tensile strength of sole-piece material, in megapascals (MPa)

f_C = rudder cross-section coefficient—

a) for normal cross-section rudders

b) 1.08 for hollow cross-section rudders; e.g. whale-tail

c) 1.19 for high lift rudders with active trailing edge.

Table 7 — Values of coefficient C_S for varying vessel speed V

V (knots)	10	11	12	13	14	15	16 and over
C_S for vessels without an outer post	2.054	1.811	1.617	1.464	1.339	1.235	1.138
C_S for vessels with an outer post	1.707	1.540	1.394	1.283	1.179	1.096	1.026

NOTE: Values of coefficient C_S for vessel speeds between those shown in the table may be obtained by linear interpolation.

6.8.7.2.3 Stiffness

Where the sole-piece is a material other than carbon steel, the moment of inertia about the vertical axis at a distance l_S from the centreline of the rudder stock shall not be less than that determined from the following formula:

$$I_S = 1.1 Z_S^{1.333} \left(\frac{207}{E_S} \right)$$

where

I_S = required moment of inertia of the sole-piece about the vertical axis, in cm⁴

Z_s = required section modulus of the sole-piece about the vertical axis as calculated in Clause 6.8.7.2.2, in cubic centimetres (cm^3)

E_s = modulus of elasticity of the sole-piece material, in gigapascals (GPa).

6.8.7.2.4 Area

Where the sole-piece is a material other than carbon steel, the cross-sectional area of the sole-piece at a distance l_s from the centreline of the rudder stock shall not be less than that determined from the following formula:

$$A_s = 2.5 Z_s^{0.667} \left[\frac{410}{UTS_s} \right]$$

where

A_s = required area of the sole-piece, in square centimetres (cm^2)

Z_s = required section modulus of the sole-piece about the vertical axis as calculated in Clause 6.8.7.2.2, in cubic centimetres (cm^3)

UTS_s = ultimate tensile strength of sole-piece material, in megapascals (MPa).

6.8.7.3 Rudder stock neck bearing

Neck bearings for rudders shall incorporate bushes and shall be fitted as shown in Figure 15. The bush shall have a length not less than that determined from the following formula:

$$l_n = k_n d_l$$

where

l_n = required length of neck bearing, in millimetres

k_n = 4 for spade rudders without an upper bearing, or 1.5 for all other balanced rudders

d_l = minimum required diameter of lower stock, in millimetres.

6.8.7.4 Spade rudder bearing pressure

High bearing loads are likely on the neck and upper bearings of a spade rudder (see Figure 14). Calculations shall be made to ensure that the pressure on the neck and upper bearings does not exceed that specified by the manufacturer of the bearings. Where allowable bearing pressure information is not available, then the maximum nominal bearing pressure shall not exceed 3.9 MPa.

NOTE: For the purposes of this calculation, a neck bearing of a rudder having no upper bearing as in Figure 14 may be modelled as two bearings (a neck bearing and an upper bearing) with a gap between the bearings of at least 1.0 times the required diameter of the lower stock d_l .

The nominal bearing pressure may be determined by first determining the rudder force from the following formula:

$$F_p = 196AV^2$$

where

- F_p = rudder force, in newtons (N)
- A = area of rudder, in square metres (m²)
- V = speed of vessel, in knots

The nominal bearing pressure is then determined as follows—

$$P_B = \frac{F_p}{dl_B}$$

where

- P_B = nominal bearing pressure, in megapascals (MPa)
- F_p = rudder force from the above formula, in newtons (N)
- d = actual diameter of rudder stock in way of the bearing, in millimetres
- l_B = length of bearing, in millimetres.

6.8.7.5 **Rudder stock upper bearing**

Upper rudder stock bearings, where fitted, shall have a length not less than the required upper stock diameter d_u in way of the bearing. For spade rudders of the type shown in Figure 14 the upper bearing (not depicted in the figure) should have a length not less than that determined from the following formula:

$$l_u = \frac{h_n d_l l_n}{h_u d_{uf}}$$

where

- l_u = length of upper bearing, in millimetres
- d_{uf} = fitted diameter of upper stock in way of upper bearing, in millimetres
- h_u = height of centre of upper bearing above centre of rudder area, in millimetres
- l_n = required length of neck bearing, in millimetres
- d_l = required diameter of lower stock in way of neck bearing, in millimetres
- h_n = height of centre of neck bearing above centre of rudder area, in millimetres.

For the purposes of this calculation, the bottom of the upper bearing should be located no less than d_l from the top of the lower bearing.

6.8.7.6 Distance from tiller or quadrant boss to nearest bearing

The distance from the tiller or quadrant boss to the nearest upper or neck bearing; gland; or other support should not exceed 2.5 times the fitted diameter of the rudder stock in way of the boss.

6.8.7.7 Rudder pintle diameter

Where a single heel pintle (Figure 15), or multiple equidistant pintles (Figure 16) are fitted, the diameter of pintles shall not be less than that determined from the following formula:

$$d_{pi} = 0.75 \frac{d_l}{\sqrt{N - K_p}} \sqrt{\frac{UTS_{stock}}{UTS_{pintle}}}$$

where

d_{pi} = required diameter of heel or intermediate pintle, in millimetres

d_l = minimum required diameter of rudder lower stock, in millimetres

N = number of pintles supporting the rudder inclusive of the heel pintle

K_p = 0 for rudders having a neck bearing, or
1 for rudders with no neck bearing

NOTE: Rudders with only a single pintle at the heel are required to have a neck bearing.

UTS_{stock} = ultimate tensile strength of stock material, in megapascals (MPa)

UTS_{pintle} = ultimate tensile strength of pintle material, in megapascals (MPa).

6.8.7.8 Rudder pintle bearings

Pintle bearings, if fitted, shall incorporate bushes. The length of pintle bearings shall not be less than that determined from the following formula:

$$l_p = k_p d_{pi}$$

where

l_p = required length of pintle bearing, in millimetres

k_p = a factor of 0.93 for balanced rudders having a bottom pintle bearing, or 1 for other rudders

d_{pi} = required diameter of pintle calculated in accordance with Clause 6.8.7.7, in millimetres.

6.8.7.9 Rudder stops

Rudders shall incorporate stops at the “full over” position to prevent the rudder coming into contact with the propeller or hull. Vertical movement shall also be limited by stops or jumping collars.

6.8.7.10 Rudder trunk and gland

The rudder trunk shall be of a thickness sufficient to support any rudder stock bearings carried within the trunk. For materials subject to corrosion, the thickness shall incorporate a 25 per cent allowance for corrosion. The thickness of the rudder trunk shall not be less than that of the hull shell thickness to which it is attached.

NOTE: The thickness of the rudder trunk is typically 25 per cent greater than that of the hull shell thickness to allow for boring, support of bearings, welding and/or integration into the structure.

The rudder trunk enclosing the rudderstock and neck bearing should extend above the fully loaded waterline. A gland shall be fitted to seal the rudder trunk if the trunk terminates below the level of the deck.

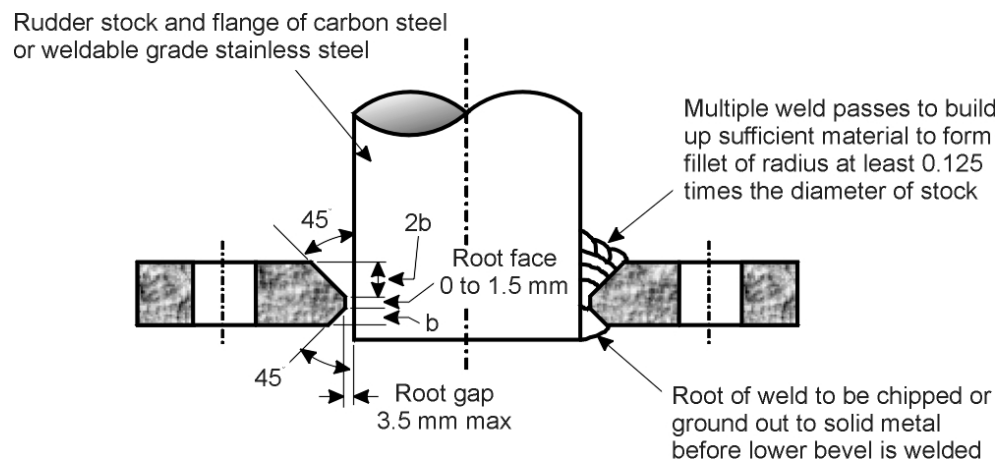

Figure 17 — Flange couplings of fabricated construction

6.8.8 Rudder couplings

6.8.8.1 Coupling types

Rudder couplings shall be one of the following types:

- Flange couplings of fabricated construction, which have been stress relieved subsequent to welding (see Figure 17).
- Flange couplings formed by upsetting the end of the stock, provided that there is no necking or narrowing of the stock.
- Taper couplings, keyed and held in place by a nut. The taper coupling may be arranged to secure the boss of a flanged coupling or

alternatively, to secure the stock directly into the mainpiece without the need of a flange coupling.

6.8.8.2 Flange coupling dimensions and bolting arrangements

The dimensions and bolting arrangements of rudder flange couplings shall be as follows:

- a) The minimum thickness of a coupling flange shall be the greater of those calculated in accordance with the following formulae—

$$t_f = k d_l \sqrt{\frac{UTS_{stock}}{UTS_{coup}}} \quad \text{or} \quad t_f = d_b \sqrt{\frac{UTS_{bolt}}{UTS_{coup}}}$$

where

- t_f = minimum flange thickness, in millimetres
- k = 0.25 for a rudder with one or more pintles, or 0.32 for a spade rudder
- d_l = required diameter of the rudder stock in way of the coupling, in millimetres
- d_b = required diameter of the coupling bolts, in millimetres, calculated in accordance with Clause 6.8.8.2 (e)
- UTS_{stock} = ultimate tensile strength of rudder stock material, in megapascals (MPa)
- UTS_{coup} = ultimate tensile strength of coupling flange material, in megapascals (MPa)
- UTS_{bolt} = ultimate tensile strength of coupling bolts of diameter calculated in accordance with Clause 6.8.8.2 (f) below, in millimetres.

- b) The fillet radius at the base of the flange shall not be less than 0.125 times the actual diameter of the stock in way of the coupling.
- c) The ligament thickness outside the coupling bolt holes shall not be less than 0.6 times the required diameter of the coupling bolt.
- d) The pitch circle radius of bolts for couplings of the forged or welded flange type shall not be less than the required diameter of the rudder stock in way of the coupling, and for couplings keyed to the stock, shall be not less than 1.25 times the required diameter of the rudder stock.
- e) Where a rudderstock is 150 millimetres or more in diameter in way of the coupling, at least 6 bolts shall be used in each coupling flange. Where the diameter is less than 150 mm, at least 4 bolts shall be used in each coupling flange.
- f) The total area of bolts shall not be less than that determined from the following formula:

$$A = \frac{0.3 d^3}{R} \sqrt{\frac{UTS_{stock}}{UTS_{bolt}}}$$

where

- A = total bolt area at root of threads, in square millimetres (mm²)
- d = required diameter of stock in way of coupling, in millimetres, calculated in accordance with Clause 6.8.4 or 6.8.5 as appropriate
- R = pitch circle radius of bolts, in millimetres
- UTS_{stock} = ultimate tensile strength of stock material, in megapascals (MPa)
- UTS_{bolt} = ultimate tensile strength of bolt material, in megapascals (MPa).

Rudder coupling bolts shall be machine finished, neat fitting and the nuts shall be locked to prevent any possibility of backing off while in service. Rudder coupling bolts need not be neat fitting on small rudders not being spade rudders and having a lower stock diameter of less than 75 mm, provided a key of dimensions complying with Clause 3.11 is incorporated into the flange coupling.

6.8.8.3 **Tapered couplings**

The dimensions of tapers and taper retaining nuts for tapered couplings shall be in accordance with the requirements for shafting given in Clauses 3.10.11 and 3.12.4, except that a taper as steep as 1 in 8 may be used.

Keys for taper couplings shall comply with the relevant requirements of Clause 3.11 and shall be sized on the required upper stock diameter.

The boss thickness of flange couplings fitted on a taper shall not be less than 1.5 times the required thickness of the key, and the boss length shall not be less than 1.6 times the required diameter of the rudder stock in way of the coupling.

6.9 **RUDDERS**

6.9.1 **Single plate rudders**

Refer to Figure 15.

6.9.1.1 **Plate thickness**

The minimum plate thickness for single plate rudders shall be the greater of those calculated in accordance with the following two formulas:

$$t = [2.5 + (0.0015 V h)] \sqrt{\frac{410}{UTS_{plate}}}$$

or

$$t = 10 \sqrt{\frac{410}{UTS_{plate}}}$$

where

- t = thickness of plating, in millimetres
- V = maximum service speed, in knots, that the vessel is designed to maintain in a fully loaded condition
- h = vertical distance between the centres of stiffeners, in millimetres
- UTS_{plate} = ultimate tensile strength of plating material, in megapascals (MPa).

6.9.1.2 **Distance between stiffeners**

The distance between centres of single plate rudder stiffeners shall not exceed 1000 mm.

6.9.1.3 **Section modulus of stiffeners**

The section modulus of the stiffeners immediately forward and aft of the stock shall not be less than that determined from the following formula:

$$Z = 0.0005 V^2 l h \left(\frac{410}{UTS_{stiff}} \right)$$

where

- Z = section modulus of stiffeners, in cubic centimetres (cm³)
- V = maximum service speed, in knots, that the vessel is designed to maintain in a fully loaded condition
- l = horizontal distance from the aft edge of the rudder to the centre of the rudder stock, in metres
- h = distance between centres of stiffeners, in millimetres
- UTS_{stiff} = ultimate tensile strength of stiffener material, in megapascals (MPa).

6.9.1.4 **Tapering of stiffeners**

The width of the stiffeners may be tapered forward and aft of the maximum widths required to satisfy the above section modulus. The minimum stiffener section modulus at the leading and trailing edges of the rudder shall not be less than that determined from the following formula:

$$Z_t = 1.7 \left(\frac{410}{UTS_{stiff}} \right) + 0.1Z$$

where

- Z_t = section modulus of stiffeners at the leading and trailing edges of the rudder, in cubic centimetres (cm³)
- Z = section modulus of stiffeners immediately forward and aft of the stock, in cubic centimetres (cm³) (see Clause 6.9.1.3)

UTS_{stiff} = ultimate tensile strength of stiffener material, in megapascals (MPa).

6.9.1.5 **Attachment**

The blade of a single plate rudder shall be attached to the mainpiece by a full penetration continuous weld. Stiffeners shall be attached to the mainpiece and blade by a double continuous fillet weld.

6.9.2 **Double plate rudders**

Refer Figure 16.

6.9.2.1 **Arrangement and testing**

Double plate rudders shall have horizontal internal webs. They shall be watertight and tested to a head of water of 2.5 m or equivalent. A means for draining shall be incorporated in the rudder.

6.9.2.2 **Plating thickness—equivalent carbon steel rudder upper stock diameter less than 75 mm**

The thickness of carbon steel plating for a double plate rudder having a required equivalent carbon steel rudder upper stock less than 75 mm diameter shall be as specified in Table 8. Horizontal and vertical webs in double plate rudders not replacing the mainpiece shall have the same thickness as the side plates. Plates forming the top and bottom of the rudders shall not be less than the thickness given in Table 8 for webs spaced at 600 mm.

NOTE: The equivalent carbon steel rudder upper stock diameter is determined by the following formula:

$$d_{ue} = d_u \sqrt[3]{\frac{410}{UTS_{stock}}}$$

where

- d_{ue} = equivalent carbon steel upper stock diameter, in millimetres
- d_u = required upper stock diameter for the actual stock material, calculated in accordance with Clauses 6.8.4.2 or 6.8.5.1, in millimetres
- UTS_{stock} = ultimate tensile strength of rudder stock material, in megapascals (MPa).

Table 8 — Carbon steel plate thickness for rudders—equivalent carbon steel rudder upper stock less than 75 mm diameter

Required equivalent carbon steel diameter of upper stock, in millimetres, calculated in accordance with Clause 6.8.4.2 or 6.8.5.1 as appropriate	Carbon steel plate thickness (mm)		
	Webs spaced 300 mm or less	Webs spaced 450 mm	Webs spaced 600 mm
less than 40	4.5	4.5	6.5
40 and over but less than 45	4.5	6.5	6.5
45 and over but less than 60	4.5	6.5	8.0
60 and over but less than 65	6.5	6.5	8.0
65 and over but less than 75	6.5	8.0	9.5

For plating material other than carbon steel, the required thickness of plating shall be determined by multiplying the tabular value by—

$$\sqrt{\frac{410}{UTS_{plate}}}$$

where

UTS_{plate} = ultimate tensile strength of the plating material, in megapascals (MPa).

6.9.2.3 **Plating thickness—equivalent carbon steel rudder upper stock diameter 75 mm and over**

Where the required equivalent carbon steel rudder upper stock diameter is 75 mm or over (see note to Clause 6.9.2.2), the thickness of the rudder side plating and webs shall not be less than that determined as follows:

The thickness of rudder side plating and webs t_p shall be determined from a reference thickness t_r adjusted for the variation between the actual spacing of web centres and a reference spacing of web centres S_p .

The reference thickness shall be determined from the following formula:

$$t_r = (6.5 + 0.117 V \sqrt{A}) \sqrt{\frac{410}{UTS_{plate}}}$$

where

t_r = reference plate thickness, in millimetres

V = speed of vessel in knots with—

- a) a minimum of 8 knots in vessels less than 30 m in measured length; and
- b) a minimum of 9 knots in vessels of 30 m in measured length and over.

A = total area of rudder, in square metres (m²)

UTS_{plate} = ultimate tensile strength of plating material, in megapascals (MPa).

The thickness of the rudder side plating t_p shall be determined from the following formula:

$$t_p = t_r + 0.015 (S_a - S_p) \sqrt{\frac{410}{UTS_{plate}}}$$

where

t_p = required minimum thickness of rudder side plating, in millimetres

t_r = reference plate thickness, in millimetres

UTS_{plate} = ultimate tensile strength of plating material, in megapascals (MPa)

S_a = actual spacing of web centres, in millimetres

S_p = reference spacing of web centres, in millimetres calculated in accordance with the following formula:

$$585 + 2.41 V \sqrt{A}$$

where

V = speed of vessel in knots with—

- a) a minimum of 8 knots in vessels less than 30 m in measured length; and
- b) a minimum of 9 knots in vessels of 30 m in measured length and over.

A = total area of rudder, in square metres (m²).

The minimum thickness of plates forming the top and bottom of the rudder shall be the greater of—

- a) the thickness of the rudder side plating t_p , calculated for the actual spacing of web centres; and
- b) the reference thickness t_r .

6.9.2.4 Attachment of stiffeners

Horizontal and vertical webs in double plate rudders shall be attached to the main-piece by continuous double fillet welds and to the plating by fillet welds consisting of 75 mm lengths, spaced 150 mm between their centres. Where the interior of the rudder is inaccessible for welding, the stiffeners shall be fitted with flat bars and the plating connected to these flat bars by continuous or slot welds.

6.9.3 Fibre-reinforced plastic (FRP) rudders

Refer to Figure 14.

6.9.3.1 Construction

FRP rudders shall incorporate a substantial spider, formed by plate arms approximately half the rudder width in length and welded to the rudder mainpiece. The spider arms shall be perforated or otherwise arranged to facilitate a rigid connection between the mainpiece and the FRP blade. The mainpiece should be continuous through the rudder wherever possible, or alternative arrangements should be made to ensure continuity of strength and alignment. The blade shall be manufactured from reinforced epoxy or polyester resins. The rudder should be filled with a suitable material such as a resin/glass dough, timber or a micro-balloon mixture.

NOTE: The formulae given in Clause 6.9.2 for double-plate rudders are not applicable to FRP rudders constructed with a spider and solid core. Typically the skins of FRP rudders have a minimum mass of reinforcement of 3000 g/m². Lighter laminates down to 2300 g/m² may suffice on small sailing vessels or where advanced composite materials are used.

6.10 STEERING NOZZLES

Refer to Figure 18.

6.10.1 Testing

Steering nozzles shall be watertight and tested to a head of water of 2.5 m or equivalent. A means for draining shall be incorporated in the nozzle.

6.10.2 Shroud plating in way of propeller blade tips

The shroud plating in way of the propeller blade tips shall extend forward and aft of this position for a distance appropriate for the limits of rotation of the nozzle. Shroud plating may be carbon or stainless steel. The thickness of this shroud plating shall be determined from the following formulae:

a) If $P \times D$ is less than or equal to 6300—

$$t_s = (11 + 0.001 P D) \sqrt{\frac{410}{UTS_s}}$$

b) If $P \times D$ is greater than 6300—

$$t_s = (14 + 0.00052 P D) \sqrt{\frac{410}{UTS_s}}$$

where

t_s = thickness of shroud plating in way of propeller tips, in millimetres

P = power transmitted to the propeller, in kilowatts

D = propeller diameter, in metres

UTS_s = ultimate tensile strength (UTS) of the shroud plating in way of propeller tips, in megapascals (MPa).

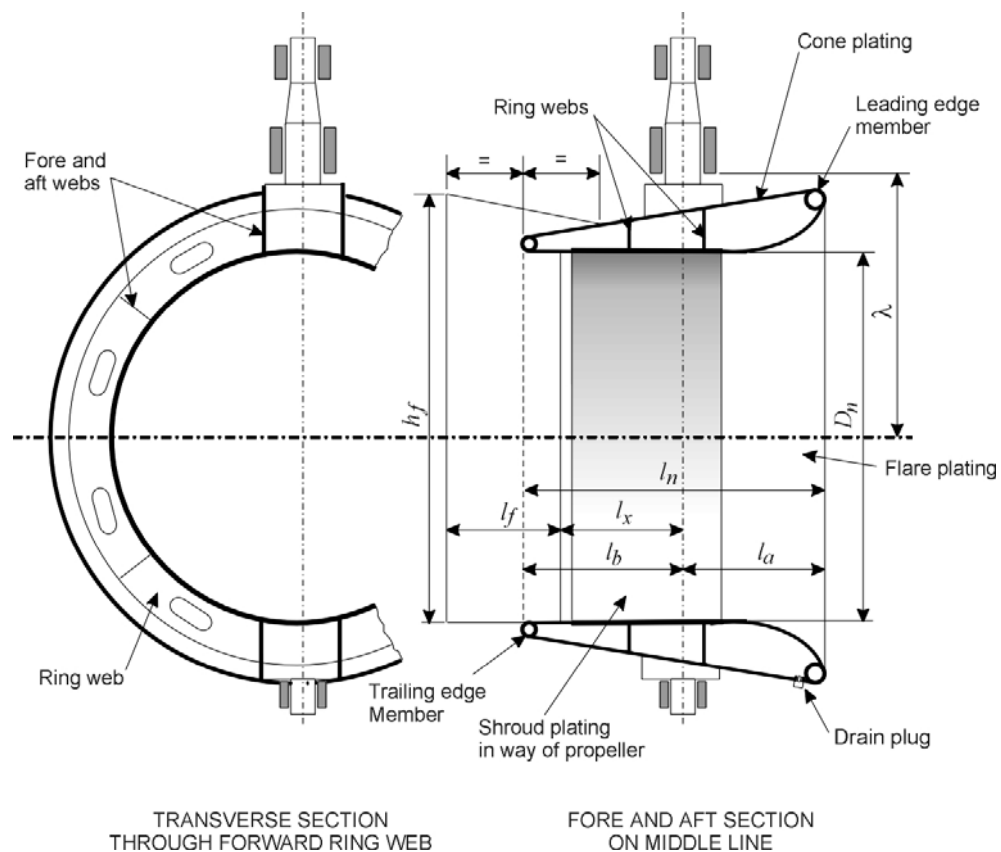

Figure 18 — Steering nozzle details and dimensions

6.10.3 Flare plating, cone plating and shroud plating clear of propeller tips

The thickness of flare plating, cone plating and shroud plating clear of propeller blade tips (see Figure 18), which shall not be less than:

$$8 \sqrt{\frac{410}{UTS_p}} \text{ mm,}$$

shall be determined in accordance with the following formula:

$$t_p = \left(t_s - 7 \sqrt{\frac{410}{UTS_s}} \right) \sqrt{\frac{UTS_s}{UTS_p}}$$

where

t_p = thickness of shroud plating clear of propeller tips, flare and cone plating, in millimetres

t_s = required thickness of shroud plating in way of the propeller tips, in millimetres

UTS_p = ultimate tensile strength of the shroud plating clear of propeller tips (assumed to be the same material as the web plating), in megapascals (MPa)

UTS_s = ultimate tensile strength of the shroud plating in way of propeller tips, in megapascals (MPa).

6.10.4 Fore and aft webs

Fore and aft webs, which shall not be less than the thickness of shroud plating clear of propeller tips, shall be fitted between the inner and outer skins of the nozzle. Fore and aft webs in way of the headbox and pintle support structure shall have their thickness increased in accordance with the following formula:

$$t_w = t_p + 4 \sqrt{\frac{410}{UTS_p}}$$

where

t_w = thickness of webs in way of headbox and pintle support, in millimetres

t_p = thickness of shroud plating other than that in way of the propeller tips, in millimetres

UTS_p = ultimate tensile strength, in megapascals (MPa), of the shroud plating clear of propeller tips (assumed to be the same material as the web plating).

6.10.5 Ring webs

Ring webs, which shall not be less than the thickness of the shroud plating clear of the propeller blade tips, shall be fitted to maintain the transverse strength of the nozzle. A minimum of two such webs should be fitted.

The thickness of ring webs in way of the headbox and pintle support shall be increased in accordance with the formula given in Clause 6.10.4, and this increased thickness shall be maintained to the adjacent fore and aft web.

6.10.6 Leading and trailing edge members

The wall thickness of leading and trailing edge members shall not be less than the required thickness of shroud plating clear of propeller blade tips.

6.10.7 Stiffening

Local stiffening shall be fitted in way of the top and bottom supports, which shall in turn be integrated with the fore and aft webs and the ring webs. Continuity of bending strength shall be maintained in areas where stiffening is fitted.

6.10.8 Fins

Fabricated fins should be adequately reinforced. The plating thickness of double plate fins should not be less than that of the plating clear of propeller tips.

6.10.9 Nozzle stock, heel pintle, etc.**6.10.9.1 Scantlings**

The diameter of the upper and lower nozzle stock shall be calculated in accordance with Clause 6.8.5 for balanced rudders, assuming the steering nozzle has the geometric properties given in Clauses 6.10.9.2 to 6.10.9.4 below (refer to Figure 18).

Scantlings for the heel pintle, keys, coupling bolts, etc., shall be determined from the required stock diameter as per the relevant clauses for rudders.

6.10.9.2 Equivalent area

The equivalent area of the nozzle and fin shall be determined from the following formula:

$$A = 2 D_n l_n + 0.85 h_f l_f$$

where

A = equivalent area of nozzle and fin, in square metres (m²)

D_n = inner diameter of the nozzle, in metres

l_n = nozzle length, in metres

h_f = mean height of fin, in metres

l_f = length of fin, in metres.

NOTE: Refer to Figure 18 for details of dimensions

6.10.9.3 Equivalent horizontal lever arm

The equivalent horizontal lever arm b shall be calculated as the greater of the absolute values of the following two formulae:

$$b = \frac{(l_f h_f (l_x + 0.2 l_f) - 1.5 D_n l_n l_a)}{A},$$

or

$$b = \frac{(l_f h_f (l_x + l_f) + 1.5 D_n l_n l_b)}{A} \left[\frac{0.45V + 2}{V + 2} \right]^2$$

where

b = equivalent horizontal distance from centre of lower stock to the centre of area of total rudder area, in metres

A = equivalent area of nozzle and fin, in square metres (m²)

D_n = inner diameter of the nozzle, in metres

l_n = nozzle length, in metres

- l_a = distance from nozzle leading edge to stock axis, in metres
 l_b = distance from nozzle trailing edge to stock axis, in metres
 l_x = distance between stock axis and fin, in metres
 h_f = mean height of fin, in metres
 l_f = length of fin, in metres
 V = speed of vessel in knots with—
- a) a minimum of 8 knots in vessels less than 30 m in measured length; and
 - b) a minimum of 9 knots in vessels of 30 m in measured length and over.

NOTE: Refer to Figure 18 for details of dimensions.

6.10.9.4 Equivalent vertical lever arm

The equivalent vertical lever arm a , in metres, shall be the vertical distance from the nozzle axis to the bottom of the nozzle stock neck bearing.

6.11 TILLER ARM OR QUADRANT

6.11.1 Section modulus of tiller arms or quadrant clear of boss

The section modulus of a tiller arm just clear of the boss, or quadrant just clear of the boss, shall not be less than that determined from the following formula:

$$Z = \frac{0.15 d_u^3 (a - b)}{1000a} \left(\frac{UTS_{Stock}}{UTS_{Arm}} \right)$$

where

- Z = required section modulus of quadrant or tiller about the vertical axis, in cubic centimetres (cm³)
 d_u = required diameter of the upper rudder stock, in millimetres, calculated in accordance with Clause 6.8.4.2 or 6.8.5.1 as appropriate
 a = distance from the point of application of the steering force on the tiller or quadrant to the centre of the rudder stock, in millimetres
 b = distance between the section of tiller or quadrant just clear of the boss and centre of the rudder stock, in millimetres
 UTS_{Stock} = ultimate tensile strength of stock material, in megapascals (MPa)
 UTS_{Arm} = ultimate tensile strength of tiller arm or quadrant material, in megapascals (MPa).

The section modulus of tiller arm or quadrant just clear of the boss about the horizontal axis shall not be less than one-third times the required value of Z determined above.

6.11.2 Section modulus at point of application of load

The section modulus at the point of application of the load shall not be less than one-third times the required value of Z calculated in Clause 6.11.1.

6.11.3 Thickness of tiller boss or quadrant boss

The thickness of the tiller boss or quadrant boss should not be less than 0.4 times the required upper rudder stock diameter. The depth of the boss shall not be less than the key length determined in accordance with Clause 6.11.4.

6.11.4 Securing of tiller or quadrant boss on the rudderstock

The tiller or quadrant boss shall be securely affixed to the rudderstock by means of a key or other equivalent means. Where a key is fitted, the size of the key shall be determined in accordance with Clause 3.11 using the required diameter of the upper stock d_u in place of the shaft diameter d .

NOTE: Methods similar to those applied to attaching shaft couplings to shafting may provide a suitable means for securing the tiller or quadrant boss to the rudder stock. See Clause 3.12.2.

CHAPTER 7 ANCILLARY SYSTEMS

7.1 SCOPE

This Chapter specifies requirements for compressed air, hydraulic and refrigeration systems. It applies to vessels of less than 35 m in measured length.

NOTE: For vessels of 35 m or more in measured length, refer to Clause 1.2.1.

7.2 OBJECTIVE

The objective of this Chapter is to control specific risks associated with the operation of certain ancillary systems or the failure of these systems.

NOTES:

1. Specific hazards associated with air compressors and their systems include the following: failure caused by overpressure in the compressor, air cooler casing or piping; hydraulic overpressure; corrosion; ingestion of inflammable vapours; overheating. Consequences of these hazards include the following: explosion; fire; loss of emergency systems; loss of control systems; inability to start propulsion machinery; personal injury or death.
2. Specific hazards associated with hydraulic power systems include the following: failure caused by hydraulic overpressure; discharge of flammable liquids; loss of hydraulic pressure. Consequences of these hazards include the following: fire; loss of emergency systems; loss of control systems; personal injury or death.
3. Specific hazards associated with refrigeration systems include the following: escape of refrigerant gas; overpressure; prolonged exposure to cold conditions. Potential consequences of these hazards include the following: environmental damage; asphyxiation; gas poisoning; fire; personal injury; hypothermia or death.

REQUIRED OUTCOMES

7.3 CONTAINMENT OF PRESSURE

Auxiliary systems must be designed and constructed to contain the system pressure and eliminate the risk of overpressure.

7.4 CONTROL THE RISK OF FIRE

Auxiliary systems must be designed and constructed to eliminate or control the risk of fire to acceptable levels.

7.5 RELIABILITY

Auxiliary systems must provide appropriate levels of reliability where operation of the auxiliary system is essential to the safety of the vessel.

7.6 MINIMISE TOXICITY AND POLLUTION

Auxiliary systems must be designed and constructed to eliminate or control to acceptable levels the risks to persons arising from the toxicity of gases used in an auxiliary system and the potential impact of these gases on the environment.

7.7 PROTECTION FROM EXTREMES OF TEMPERATURE

Auxiliary systems must be designed and constructed to eliminate or control to acceptable levels the risks to persons being exposed to extremes of temperature associated with the operation of an auxiliary system.

EXAMPLE

Arrangements to eliminate or control the risk to a person being trapped within a refrigerated space.

DEEMED-TO-SATISFY SOLUTIONS

7.8 COMPRESSED AIR SYSTEMS

7.8.1 Application

Clause 7.8 applies to air compressors supplying compressed air for purposes other than breathing apparatus.

7.8.2 Compliance

For the purpose of this National Standard, a compressed air system shall be deemed to have satisfied the Required Outcomes in Clauses 7.3 and 7.4 if it complies with Clauses 7.8.3 to 7.8.9.

7.8.3 Relief valves—compressor

An air compressor shall be provided with one or more relief valves capable of discharging the maximum capacity of the compressor, and set so that when the compressor discharge valve is closed while the compressor is running normally, the maximum accumulation pressure will not exceed 10 per cent of the working pressure.

7.8.4 Relief valves—casing

The casing of an air cooler of an air compressor shall be fitted with a relief valve or a safety diaphragm to provide protection against an air tube bursting.

7.8.5 Drainage

An air compressor shall incorporate means for draining water and oil from the intermediate and final discharge stages.

7.8.6 Location of air intake

The air intake for a compressor shall be located to minimise the induction of exhaust gases, oil vapours or other potentially hazardous fumes.

7.8.7 Delivered air temperature

An air compressor shall be designed and installed so that the temperature of the air delivered from the after cooler does not exceed 93°C.

7.8.8 Pressure monitoring

A pressure gauge shall be fitted between the after cooler and the compressor discharge.

7.8.9 Pressure piping

Pressure piping shall meet the requirements specified in AS 4041.

7.9 HYDRAULIC POWER SYSTEMS**7.9.1 Compliance**

For the purpose of this National Standard, a hydraulic system shall be deemed to have satisfied the Required Outcomes in Clauses 7.3, 7.4 and 7.5 if it complies with Clauses 7.9.2 to 7.9.5.

7.9.2 Relief protection

Hydraulic pumps shall have pressure relief protection on the discharge side. Such pressure relief protection shall operate in a closed circuit.

7.9.3 Materials and hydraulic fluid

The materials of hydraulic pumps, motors and accessories shall be compatible with the hydraulic fluid. Hydraulic fluid shall be non-flammable or shall have a flashpoint of 157°C or over.

7.9.4 Hydraulic hose and piping

The application and installation of, and the fittings for, hydraulic hose and piping shall comply with the manufacturer's instructions. Unless otherwise provided for in Clause 7.9.5, hydraulic hose shall comply with AS 3791, and hydraulic piping shall comply with AS 4041.

7.9.5 Use of nylon tubing in hand hydraulic systems

Nylon tubing may be used in hand hydraulic applications on vessels provided that—

- a) it meets the requirements of AS 3791 or an equivalent national or international standard;
- b) it is stabilised against degradation due to exposure to ultra-violet light;
- c) it is only used where suitable for the application;
- d) it has a pressure cycling resistance equivalent to that required for hoses complying with AS 3791; and
- e) it does not pass through a space designated as a high risk or machinery space (see Part C Section 4: Fire Safety of the NSCV), or alternatively, the tubing is adequately shielded from the effects of fire within such a space.

7.10 REFRIGERATION**7.10.1 Compliance**

For the purpose of this National Standard, a refrigeration system shall be deemed to have satisfied the Required Outcomes in Clauses 7.3 to 7.7 if it complies with Clauses 7.10.2 to 7.10.8.

7.10.2 System design, construction and testing

A refrigeration system shall be designed, constructed and tested in accordance with AS/NZS 1677.1 and AS/NZS 1677.2.

NOTE: AS/NZS 1677.1 classifies refrigerants on a risk basis (i.e. toxic/non-toxic, flammable/non-flammable) and contains some basic technical information on their physical properties. The most important criteria is the "practical limit" of the refrigerant which forms the basis of AS/NZS 1677.2, which covers safety requirements for fixed refrigeration systems.

7.10.3 Refrigerant gas

Gas used in a refrigeration system shall be selected in accordance with AS/NZS 1677.1.

NOTES:

1. For additional guidance, refer to the Refrigerant Selection Guide, published by the Australian Institute of Refrigeration Air Conditioning and Heating (Inc) dated June 1998.
2. The Australian Government is a signatory to the Montreal Protocol, which sets out a mandatory timetable for the phase-out of ozone-depleting substances and urges additional action to minimise damage to the ozone layer. The Refrigerant Selection Guide includes information on the Protocol and on alternatives to CFC refrigerants.

7.10.4 Restrictions pertaining to the use of ammonia

The following restrictions apply in refrigeration systems:

- a) Ammonia shall not be used as a refrigerant on a Class I vessel.
- b) An ammonia plant shall not be installed in a manned machinery space.

7.10.5 Alarm systems and exits

A refrigerated space that a person may be required to enter shall be provided with—

- a) a manually activated alarm which is audible outside the space and which can only be activated and cancelled from within the space;
- b) means inside the space for locating the exit door and alarm, should lights in the space be switched off or fail; and
- c) means to manually open every door from both outside and inside the space.

7.10.6 Proximity to accommodation space

Boundaries between a refrigeration machinery space and sleeping accommodation shall be gastight. The refrigeration system shall be arranged so that refrigerant gas cannot migrate to an accommodation space. The refrigeration system shall not be used for air-conditioning purposes.

NOTE: Clause 7.10.6 does not apply to the piping associated with dedicated air conditioning installations that serve a particular accommodation space.

7.10.7 Ventilation

Spaces containing refrigeration machinery shall be provided with ventilation to the outside air, either by natural or mechanical means. The

minimum air ventilation rates and openings shall be in accordance with AS/NZS 1677.2.

7.10.8 Respiratory breathing apparatus

The requirements for respiratory breathing apparatus shall be determined by the toxicity and flammability of the refrigerant used and the design of the refrigeration system. Respiratory breathing apparatus shall be located in a position unlikely to become inaccessible in case of leakage of gas.

NOTE: AS 1677.1 provides a classification system for the toxicity and flammability of gases.