



**Australian Government**  
**Australian Maritime Safety Authority**

## **National Standard for Commercial Vessels**

### **PART C - Design and Construction**

### **SECTION 2 - Watertight and Weathertight Integrity**

**Edition – External Draft 0.1**

## Edition 1

Edition 1 was first published on xx xxxx xxxx.

Edition 1 was adopted by the Transport and Infrastructure Council (TIC) on xx month year.

© Australian Maritime Safety Authority 2020.

The Australian Maritime Safety Authority encourages the dissemination and exchange of information provided in this publication.

Except as otherwise specified, all material presented in this publication is provided under Creative Commons Attribution 4.0 International licence. This excludes:

- the Commonwealth Coat of Arms
- this department's logo
- content supplied by third parties.

The Creative Commons Attribution 4.0 International Licence is a standard form licence agreement that allows you to copy, distribute, transmit and adapt this publication provided that you attribute the work. The details of the version 4.0 of the licence are available on the Creative Commons website, as is the full legal code for that licence.

### **Attribution**

AMSA's preference is that you attribute this publication (and any material sourced from it) using the following wording: © Australian Maritime Safety Authority 2020.

Published by Australian Maritime Safety Authority, GPO Box 2181 Canberra, ACT 2601.

All enquiries to be addressed to the General Manager, Standards, Australian Maritime Safety Authority.

### **Disclaimer**

The Australian Maritime Safety Authority accepts no liability for the accuracy of the information nor its use or the reliance placed on it.

## Foreword

This Section of the National Standards for Commercial Vessels (NSCV) was developed following a review of the Uniform Shipping Laws (USL) Code Section 5C Watertight subdivision of passenger vessels, Section 5D Watertight subdivision of Class 2 and Class 3 vessels and Section 7 Load lines. This is the final USL Code design and construction standard to be modernised and replaced by a new section of the NSCV.

In drafting this Section, consideration was given to a number of factors including the following:

- a) Technological developments that have occurred in relation to watertight and weathertight closing elements over the past 30 years for vessels of the types engaged in domestic operations in Australia.
- b) Problems with the application or interpretation of provisions within the USL Code Sections 5C, 5D and 7.
- c) The introduction of a performance-based standard with multiple options for compliance as an alternative to prescriptive standards.
- d) The incorporation of the IMO International Convention of Load Lines (ICLL). The ICLL has long recognised that limitations on the draft to which a vessel may be loaded make a significant contribution to the safety of the vessel. These limits are given in the form of freeboards and this is why this standard introduces a freeboard mark for all vessels. The other main objective of the ICLL is watertight and weathertight integrity.
- e) Domestic commercial vessel incident data.

AMSA drafted this Section with the assistance of an industry technical advisory panel comprising industry representatives, including accredited marine surveyors, designers, representatives of industry associations and members from an educational institution.

## Contents

Chapter 1 Preliminary .....	7
1.1 Scope .....	7
1.2 Application.....	7
1.3 Reference documents .....	7
1.4 Definitions .....	10
Chapter 2 Required outcomes .....	14
2.1 Meeting the required outcomes .....	14
2.2 The required outcomes .....	14
Chapter 3 Class 1 and 2 vessels of 24 m or more in load line length in offshore waters .....	16
3.1 Application.....	16
3.2 International Convention on Load Lines (ICLL) .....	16
3.3 Watertight and weathertight doors.....	16
3.4 Side scuttles, windows and skylights.....	16
3.5 Protection of the crew and means for safe passage of crew .....	17
3.6 Marking of doors, mechanisms and valves .....	17
3.7 Escape hatches.....	18
3.8 Load line certificates.....	18
Chapter 4 Class 1, 2 and 3 vessels less than 24 m measured length .....	19
4.1 Application.....	19
4.2 Weather decks and superstructure.....	19
4.3 Recesses .....	19
4.4 Flush decked barges .....	20
4.5 Collared vessels .....	20
4.6 Watertight and weathertight doors.....	21
4.7 Hatches and coamings.....	21
4.8 Ventilation .....	22
4.9 Weathertight and watertight closing components .....	23
4.10 Air Pipes .....	27
4.11 Materials for seacocks, through-hull fittings, valves and associated piping systems .....	28
4.12 Bungs, drain plugs and docking plugs.....	28
4.13 Portlights and windows.....	28

4.14	Skylights and skylight hatches.....	30
4.15	Marking of doors, mechanisms and valves .....	31
4.16	Rapid drainage of cockpit, well deck or recess .....	31
4.17	Freeing ports .....	34
4.18	Scuppers and discharges.....	34
4.19	Maximum displacement.....	35
4.20	Freeboard Mark.....	35
Chapter 5 Class 1 and 2 vessels 24 m or more in load line length in sheltered waters .....		36
5.1	Application.....	36
5.2	Modifications to the International Convention on Load Lines (ICLL) for sheltered water vessels .....	36
5.3	Maximum displacement.....	40
5.4	Freeboard mark.....	40
Chapter 6 Class 3 vessels 24 m or more in measured length .....		41
6.1	Application.....	41
6.2	Weather Decks.....	41
6.3	Recesses and hull Integrity .....	41
6.4	Watertight bulkheads.....	41
6.5	Watertight and weathertight doors.....	42
6.6	Hatchways closed by covers .....	42
6.7	Other deck openings .....	43
6.8	Machinery space openings.....	43
6.9	Ventilators .....	43
6.10	Air pipes and sounding devices.....	44
6.11	Portlights, windows and skylights .....	44
6.12	Freeing ports .....	45
6.13	Scuppers and discharges .....	46
6.14	Maximum displacement.....	47
6.15	Freeboard mark.....	47
6.16	Portable fish-hold divisions.....	47
6.17	Flooding of fish-holds .....	47
6.18	Weathertight and watertight closing components.....	47
6.19	Marking of doors, mechanisms and valves .....	48
Chapter 7 Assessment, Installation and testing of watertight and weathertight closing appliances and equipment .....		53

7.1	Application.....	53
7.2	Competence.....	53
7.3	Assessment.....	53
7.4	Installation and testing.....	53
Annex A	Freeboard and Load Line Mark.....	56
A1	Scope of Annex.....	56
A2	Objective.....	56
A3	Specifications of the deck line and freeboard mark.....	57
A4	Dimensions of the load line mark.....	59
A5	Determining the appropriate load lines within the Australian Exclusive Economic Zone (AEEZ) and adjacent Islands.....	59
Annex B	Overview of ICLL requirements for domestic commercial vessels.....	62
B1	Scope of Annex.....	62

## Chapter 1 Preliminary

### 1.1 Scope

- (1) NSCV Section C2 provides the design, construction, installation and maintenance standards for:
  - (a) watertight and weathertight integrity;
  - (b) rapid drainage of water from decks;
  - (c) reserve buoyancy; and
  - (d) prevention of overloading.
- (2) Chapter 2 specifies the required outcomes. Chapter 3 through to Chapter 6 specify the deemed to satisfy solutions for meeting the required outcomes.
- (3) Chapter 7 provides requirements for the assessment, installation and testing of watertight and weathertight closing appliances and equipment.
- (4) Annex A provides details of the freeboard and load line marks required.
- (5) Annex B provides an overview of the requirements of the ICLL that apply to domestic commercial vessels under Chapters 3 and 5. It is guidance only and is not a normative part of this standard.

*Note 1* Section 1.6 of NSCV Part B provides for approved equivalent means of compliance if a vessel complies with a standard not mentioned in this Section that is equivalent to the relevant deemed to satisfy solution(s).

*Note 2* This section should be read in conjunction with NSCV Part B.

### 1.2 Application

This standard applies to all domestic commercial vessels except:

- (a) special vessels as defined in NSCV Part F Special vessels (Part F), which must comply with Part F and are not required to comply with this section unless Part F specifies otherwise; and
- (b) non-survey vessels as defined in NSCV Part G Non-survey vessels (Part G), which must comply with Part G and are not required to comply with this section unless Part G specifies otherwise.

*Note 1* Marine Order 503 and Marine Order 507 require specified vessels to comply with NSCV Section C2, as a condition of the certificate of survey and/or load lines certificate.

*Note 2* Some fast craft may require a load line, as specified in NSCV Part F.

### 1.3 Reference documents

Each document mentioned in the following table is:

- (a) referenced in this Section; and
- (b) the latest revision of the document, including amendments, unless stated otherwise.

*Note* Section 1.7 in NSCV Part B provides that national, regional or international standards adopted or incorporated by reference in the NSCV are adopted or incorporated by reference as in force from time to time.

Publisher	Document	Available
Australian Maritime Safety Authority	Marine Order 503 Marine Order 507 <i>National Standard for Commercial Vessels</i> Part B — <i>General requirements</i> Part C — <i>Design and construction</i> Part C, Section 1 — <i>Arrangement, accommodation and personal safety</i> Part C, Section 3 — <i>Construction</i> Part C, Section 4 — <i>Fire Safety</i> Part C, Section 5A — <i>Machinery</i> Part C, Section 6A — <i>Intact Stability requirements</i> Part C, Section 6B — <i>Buoyancy and stability after flooding</i> Part C, Section 6C — <i>Intact Stability Tests and Stability Information</i> Part C, Section 7A — <i>Safety equipment</i> Part F — <i>Special vessels</i> Part G — <i>Non-survey vessels</i>	AMSA website at <a href="https://www.amsa.gov.au">https://www.amsa.gov.au</a>
American Boat and Yacht Council	ABYC H-27 <i>Seacocks, Thru-hull fittings, and drain plugs</i> ABYC T-5 <i>Safety Signs and Labels</i> ABYC H-3 <i>Exterior Windows, Windshields, Hatches, Doors, Port Lights, and Glazing Materials</i>	ABYC website at <a href="https://abycinc.org/">https://abycinc.org/</a>
The British Standards Institution	BS ISO 21005:2018 <i>Ships and Marine Technology – Thermally Toughened Safety-Glass Panes for Windows and Side Scuttles</i>	bsi website at <a href="http://shop.bsigroup.com">shop.bsigroup.com</a>
International Maritime Organization	International Convention on Load Lines (ILLC) and Protocol of 1988 (ILLC)	IMO website at <a href="http://imo.org">http://imo.org</a>
International Standards Organization	ISO 1751:2012 <i>Ships and marine technology — Ships' side scuttles</i> ISO 3903:2012 <i>Ships and marine technology — Ships' ordinary rectangular windows</i> ISO 5778:1998 <i>Ships and marine technology — Small weathertight steel hatches</i> ISO 5797:2004 <i>Ships and marine technology — Windows and side scuttles for fire-resistant constructions</i>	ISO website at <a href="http://www.iso.org">http://www.iso.org</a>



Publisher	Document	Available
	<p>ISO 6042:2015 <i>Ships and marine technology — Weathertight single-leaf steel doors</i></p> <p>ISO 6185-3:2014 <i>Inflatable boats - Part 3: Boats with a hull length less than 8 m with a motor rating of 15 kW and greater</i></p> <p>ISO 6185-4:2014 <i>Inflatable boats - Part 4: Boats with a hull length of between 8 m and 24 m with a motor power rating of 15 kW and greater</i></p> <p>ISO 6345:1990 <i>Shipbuilding and marine structures — Windows and side scuttles — Vocabulary</i></p> <p>ISO 7010:2019: <i>Graphical symbols - Safety colours and safety signs - Registered safety signs</i></p> <p>ISO 9093-1:1994 <i>Small craft — Seacocks and through-hull fittings — Part 1: Metallic</i></p> <p>ISO 9093-2:2002 <i>Small craft — Seacocks and through-hull fittings — Part 2: Non-metallic</i></p> <p>ISO 11336 [including Parts 1 to 6] <i>Large yachts — Strength, weather tightness and watertightness of glazed openings</i></p> <p>ISO 11812: 2015 <i>Small craft – Watertight cockpits and quick-draining cockpits</i></p> <p>ISO 12216 2002 <i>Small craft — Windows, portlights, hatches, deadlights and doors — Strength and watertightness requirements</i></p> <p>ISO 14726:2008 <i>Ships and marine technology — Identification colours for the content of piping systems</i></p> <p>ISO 14884:2015 <i>Large yachts — Weathertight doors — Strength and weathertightness requirements</i></p> <p>ISO 17940:2015 <i>Ships and marine technology — Hinged watertight doors</i></p> <p>ISO 21005:2018 <i>Ships and marine technology — Thermally toughened safety glass panes for windows and side scuttles</i></p> <p>ISO 24409-2 <i>Ships and marine technology - Design, location and use of shipboard safety signs, fire control plan signs, safety notices and safety markings.</i></p>	

## 1.4 Definitions

- (1) A term that is used in this Section but is not defined in this Section, and which is defined or used in the International Convention Load Lines (ICLL), has the meaning given by the ICLL.

- (2) In this Section:

**collared vessels** has the same meaning as in NSCV Subsection C6A.

**cockpit vessel** has the same meaning as in NSCV Subsection C6A.

**enclosed superstructure** means a superstructure with:

- (a) enclosing bulkheads complying with the applicable provisions of NSCV Section C3; and
- (b) access openings, if any, in the bulkheads fitted with doors complying with the applicable requirements of this Section; and
- (c) all other openings in the side or ends of the superstructure fitted with efficient weathertight means of closing.

**exposed decks** include top decks of superstructures, deckhouses, companionways and other similar deck structures.

**flush decked vessel** has the same meaning as in NSCV Subsection C6A.

**ICLL** means the International Convention on Load Lines, done at London on 5 April 1966, as amended from time to time.

**load line length (LLL)** has the same meaning as 'length' in Regulation 3 of the ICLL.

**least moulded depth (D)** has the same meaning as given in the ICLL.

**Marine Order 503** means *Marine Order 503 (Certificates of survey — national law) 2018*.

**Marine Order 507** means *Marine Order 507 (Load line certificates — national law) 2018*.

**position 1** means upon freeboard decks and raised quarterdecks, or other exposed decks lower than one standard height of superstructure above the freeboard deck, and upon exposed decks situated forward of a point located a quarter of the ship's length from the forward perpendicular that are located lower than two standard heights of superstructure above the freeboard deck.

*Note* For an illustration – see Figures 1, 2 and 3.

**position 2** means upon exposed decks situated:

- (a) abaft a quarter of the ship's length from the forward perpendicular and located at least one standard height of superstructure above the freeboard deck and lower than two standard heights of superstructure above the freeboard deck; or
- (b) forward of a point located a quarter of the ship's length from the forward perpendicular and located at least two standard heights of superstructure above the freeboard deck and lower than three standard heights of superstructure above the freeboard deck.

*Note* For an illustration – see Figures 2 and 3.

**portlight** means a side scuttle or a porthole.

**pound board** means a portable board or side plate used to form a space or container on a deck and may be located by fixed or portable stanchions.

**portholes** are a round or oval opening with an area not exceeding 0.16m<sup>2</sup>. Round or oval openings with an area exceeding 0.16m<sup>2</sup> should be treated as windows.

**recess (noun)** means an exposed portion of deck bounded by solid bulwarks or other structures that cause the deck to be susceptible to the unwanted retention of water. A volume open to the air that can retain water within the range of loading conditions and corresponding trims.

*Examples* 1. inset, 2. Space, 3. cockpit, 4. well.

**service category** means the category the National Regulator assigns a vessel mentioned in NSCV Part B.

**side scuttles** are a round or oval opening with an area not exceeding  $0.16\text{m}^2$ . Round or oval openings with an area exceeding  $0.16\text{m}^2$  should be treated as windows.

**skylight** means an opening in a ship's deck that is covered with translucent or transparent material and is designed to admit light.

**standard height of superstructure** means:

- (a) for vessels 24 m or more in load line length: the standard height of a superstructure in accordance with ICLL Annex 1, Regulation 33; and
- (b) for vessels less than 24 m in load line length: 1.8m.

For vessels with four or more levels of superstructure, contact the National Regulator.

*Note* For an illustration – see Figures 1, 2 and 3.

**watertight** has the same meaning as the term is given in SOLAS.

**weathertight** means that in any sea conditions water will not penetrate the vessel.

**well deck vessel** has the same meaning as in NSCV Subsection C6A.

**windows are either:**

- (a) rectangular openings which have a radius at each corner relative to the window size complying with this standard; or
- (b) round or oval openings with an area  $\geq 0.16\text{m}^2$ .

**85% of the least moulded depth (d1)** has the same meaning as given in the ICLL.

**Figure 1 Position 1, and standard height of superstructure diagram for a typical <12 m vessel**

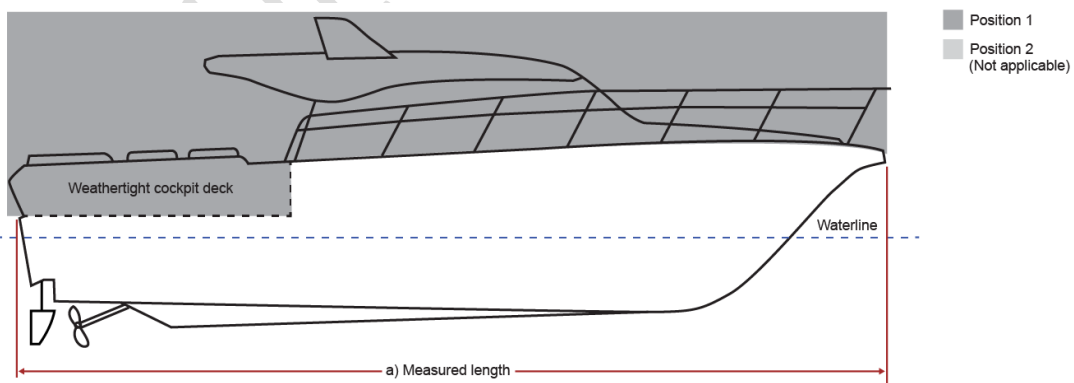

*Note for Figure 1* a) Measured length is defined in NSCV Part B

**Figure 2 Position 1, Position 2, and standard height of superstructure diagram for a typical vessel  $\geq 24$  m with two levels of superstructure**

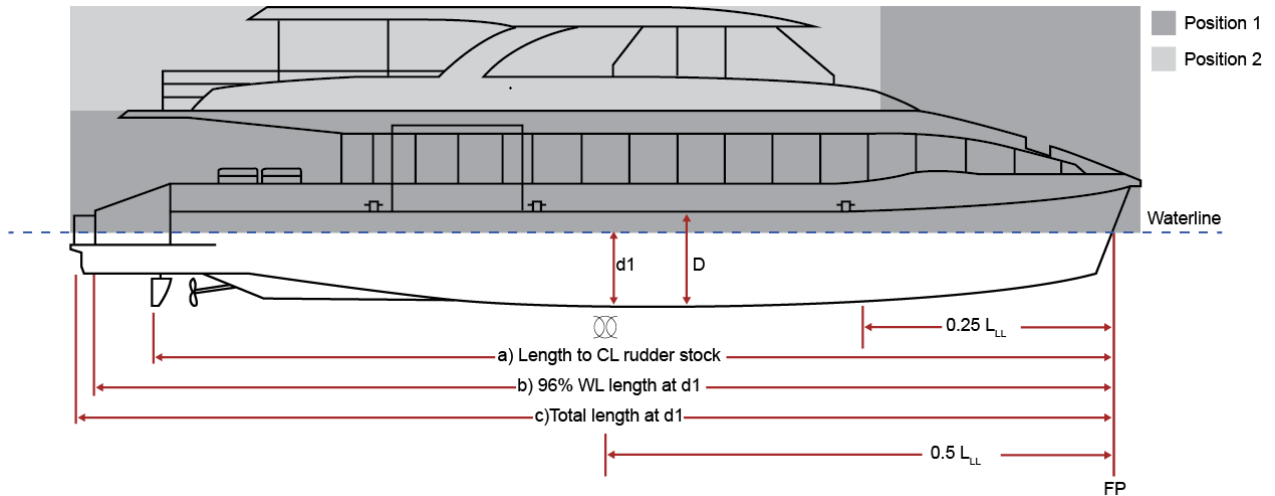

*Note 1 for Figure 2* In accordance with the ICLL, the load line length of the vessel is the greater of:

- a) length of CL rudder stock; and
- b) 96% WL length at  $d_1$ .

*Note 2 for Figure 2* Vessels  $\geq 12$ m to  $< 24$ m may have a similar position 1 and position 2 to that shown in Figure 2 depending on the vessel's levels of superstructure.

**Figure 3 Position 1, Position 2, and standard height of superstructure diagram for a typical vessel  $\geq 24$  m with three levels of superstructure (load line length vessel)**

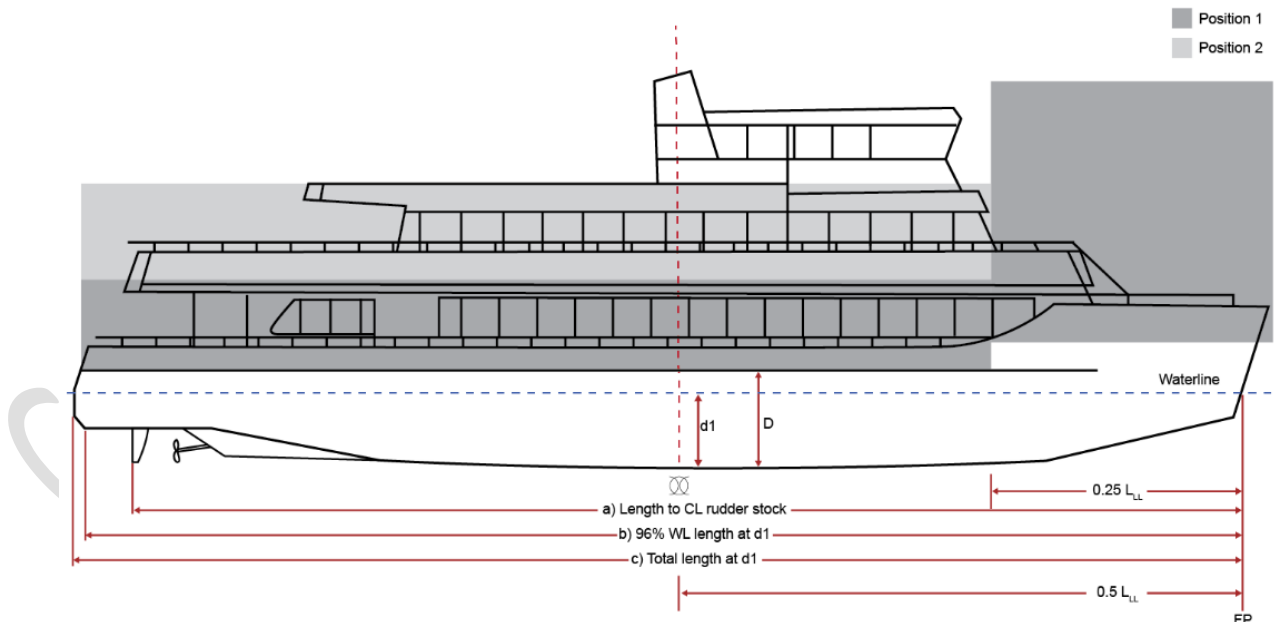

*Note 1 for Figure 3* In accordance with the ICLL, the load line length of the vessel is the greater of:

- a) length of CL rudder stock; and
- b) 96% WL length at  $d_1$ .

*Note 2 for Figure 3* For the purposes of load line, amidships is half of the load line length

- (3) In this Section, the following terms have the meaning given by the Dictionary in NSCV Part B:

Class 1 vessel	Class 2 vessel	Class 3 vessel
depth	domestic commercial vessel	measured length
operational area	owner	partially smooth waters
Recognised Organisation	significant wave height	smooth waters
SOLAS	vessel use category	

CONSULTATION DRAFT

## Chapter 2 Required outcomes

### 2.1 Meeting the required outcomes

- (1) The vessel must be fitted with watertight and weathertight integrity measures, which are designed, constructed, installed, maintained and serviced so that the required outcomes mentioned in 2.2 are met.
- (2) The required outcomes are met if the deemed to satisfy solutions contained in chapters 3 to 7 that apply to the vessel are met.
- (3) If a vessel does not fall into a specific chapter of this section, the requirements in Chapter 4 apply.

*Example* No chapters apply to a Class 2C vessel that has both: a load line length of less than 24 m and a measured length of 24 m or more. In this case, Chapter 4 applies to the vessel.

### 2.2 The required outcomes

#### A. Controlling the risk of water reaching buoyant spaces within the vessel

A vessel must have measures to prevent, or limit to an acceptable level, the likelihood, in both normal and abnormal conditions, of water entering the buoyant spaces within the vessel.

*Example* The designer must ensure that the risk of water entering watertight components (windows, hatches, valves etc.) is mitigated appropriately. This may include selecting items with adequate strength for their size and position on the vessel.

#### B. Rapid drainage of water to reduce the risk of entrapped water on decks.

A vessel must be designed, constructed and have measures to prevent, or limit to an acceptable level, the likelihood of water encroaching or becoming entrapped on decks, at all service drafts and speeds and within the sea and weather conditions likely to be encountered in the vessel's intended area of operation.

#### C. Reducing the risk of capsizing or foundering by flooding through penetrations through the effective watertight envelope.

A vessel must be designed and constructed to prevent, or limit to an acceptable level, the likelihood of: progressive flooding, disabling of essential or emergency systems, entrapment of persons due to flooding and excessive heel and/or trim.

#### D. Preservation of vessel function

A vessel must have measures to prevent, or control to an acceptable level, the likelihood of systems or spaces necessary for the safety of the vessel becoming inoperative through exposure to, or entry of, water in normal or abnormal conditions.

#### E. Safe loading conditions

A vessel must have sufficient reserve buoyancy for the intended voyage and must not be overloaded. Visual indications of, or information outlining, maximum safe loading must be prominently marked on or affixed to the vessel.

*Note* The freeboard mark, load line mark and maximum load capacity placard, are all visual references to monitor loading and to assist in the safe loading of the vessel. Other tools also exist to assist with safe loading, such as a stability booklet or stability notice.

**F. Access to information**

Persons responsible for the safety of a vessel must have ready access to accurate information needed to identify hazards, control loading and undertake other essential actions to secure its watertight and weathertight integrity.

*Example* The operator of the vessel should have access to clear instructions in the safety management system and the ship's stability booklet. This might include the watertight door status, instructions about the safe loading of the vessel, load line or freeboard marks and maximum load capacity placard.

CONSULTATION DRAFT

## Chapter 3 Class 1 and 2 vessels of 24 m or more in load line length in offshore waters

(Required outcomes: Chapter 2)

### 3.1 Application

This chapter contains the deemed to satisfy solutions for all vessels in service categories 1A, 1B Extended, 1B, 1C, 2A, 2B Extended, 2B, and 2C, that are 24 m or more in load line length.

### DEEMED TO SATISFY SOLUTIONS

#### 3.2 International Convention on Load Lines (ICLL)

- (1) The vessel must comply with the ICLL subject to the specifications, modifications and additional requirements contained in clauses 3.3 to 3.8 of this Chapter.
- (2) For the purposes of subsection (1), the ICLL applies to the vessel as if the vessel was a vessel engaged on an international voyage.
- (3) When the ICLL uses the term 'Administration', for the purpose of this Section it means the National Regulator.
- (4) Where a term used in the ICLL or in this Chapter is not defined in the ICLL, the definitions at clause 1.4 of this Section apply.
- (5) Annex B of this Section provides guidance on the requirements of the ICLL and how they apply to domestic commercial vessels.

*Note 1* Annex B provides a summary of all the relevant provisions of the ICLL for domestic commercial vessels subject to this Chapter.

*Note 2* In accordance with Marine Order 507, a Recognised Organisation or an Accredited Marine Surveyor with the appropriate accreditation may carry out load line surveys on domestic commercial vessels (in accordance with the accreditation category and any conditions of accreditation).

#### 3.3 Watertight and weathertight doors

- (1) In addition to the requirements of the ICLL, watertight and weathertight doors must comply with the design and construction requirements contained in one of the following standards that is applicable to the type and operations of the vessel:
  - (a) ISO 14884:2015 *Large yachts — Weathertight doors — Strength and weathertightness requirements*;
  - (b) ISO 6042:2015 *Ships and marine technology — Weathertight single-leaf steel doors*;
  - (c) ISO 17940:2015 *Ships and marine technology — Hinged watertight doors*; or
  - (d) the rules of a Recognised Organisation covering watertight and weathertight doors.

*Note* A deemed to satisfy standard is only applicable to vessels within the scope of the standard. Many ISO standards have different operational ranges to those in the NSCV. The appropriate standard for the intended type, operations and operational area of the vessel must be chosen.

- (2) The doors must be assessed, installed and tested in accordance with Chapter 7.

#### 3.4 Side scuttles, windows and skylights

- (1) In addition to the requirements of the ICLL, the design and construction of side scuttles, windows and skylights on the vessel must comply with one of the following standards that is applicable to the type and operations of the vessel:
  - (a) ISO 1751 *Shipbuilding and marine structures — Ships' side scuttles*;



- (b) ISO 3903 *Shipbuilding and marine structures — Ships' ordinary rectangular windows*;
- (c) ISO 5797 *Ships and marine technology — Windows and side scuttles for fire-resistant constructions*;
- (d) ISO 614: 2012 *Ships and marine technology — Toughened safety glass panes for rectangular windows and side scuttles — Punch method of non-destructive strength testing*;
- (e) ISO 6345 *Shipbuilding and marine structures — Windows and side scuttles — Vocabulary*;
- (f) ISO 21005 *Shipbuilding and marine technology — Thermally toughened safety-glass panes for windows and side scuttles*;
- (g) ISO 11336 *Large yachts (≥ 24m and up to 3,000 gross tonnage) - Strength, weather tightness and watertightness of glazed openings*; or
- (h) the rules of a Recognised Organisation.

*Note* A deemed to satisfy standard is only applicable to vessels within the scope of the standard. For example, fitting large yacht windows to a salvage tug is not appropriate, and many ISO standards have different operational ranges to those in the NSCV. The appropriate standard for the intended type, operations and operational area of the vessel must be chosen.

- (2) The side scuttles, windows and skylights must be assessed, installed, and tested in accordance with Chapter 7.
- (3) Windows fitted in superstructures or weathertight deckhouses must be efficiently secured to the structure. The glass must be of the toughened safety glass type.

### 3.5 Protection of the crew and means for safe passage of crew

Regulations 25 and 25-1 of the ICLL do not apply if the vessel complies with NSCV Section C1.

### 3.6 Marking of doors, mechanisms and valves

- (1) Suitable notices and signs must be provided on:
  - (a) all watertight and weathertight doors to indicate the required watertight integrity status or damage control requirements; and
  - (b) valves and closing appliances relating to damage control and watertight integrity.
- (2) The notices and signs must indicate the purpose of the control(s), the operating procedure and any precautions to be observed, as necessary.

*Note* ISO 14726 *Ships and marine technology — Identification colours for the content of piping systems* may assist in identifying valves requiring action for damage control or watertight integrity purposes.

- (3) The notices and signs must comply with one of the following standards for markings and graphical symbols, as applicable to the type of door, valve or closing device:
  - (a) ISO 7010:2019 *Graphical symbols - Safety colours and safety signs- Registered safety signs*;
  - (b) ISO 24409-2 *Ships and marine technology - Design, location and use of shipboard safety signs, fire control plan signs, safety notices and safety markings*;
  - (c) IMO *Safety and operating instruction for trained personnel (SIS)*, IMO Resolution A 952 (23) and IMO Resolution A 654 (16); or
  - (d) IMO *Mandatory Action Signs*.

**Figure 4 Example of an IMO Mandatory Action Sign for watertight doors**

### 3.7 Escape hatches

Hatches used for escape purposes must be:

- (a) capable of being opened from both sides;
- (b) readily identifiable and either:
  - (i) have the text “MUST BE CLOSED AT SEA” and “ESCAPE - DO NOT OBSTRUCT” in a contrasting colour that is highly visible; or
  - (ii) have IMO signage complying with IMO Resolution A.1116(30) and ISO 24409, with a minimum size of 10 cm x 30 cm. The applicable signage signs are “ESCAPE HATCH”, “EMERGENCY EXIT KEEP CLEAR” and “THIS HATCH MUST BE KEPT CLOSED AT SEA”;
- (c) easy and safe to use, having due regard to their position; and
- (d) when located within the forward quarter of a vessel’s length, must be forward hinged.

*Note* See NSCV Section C1 for required markings of escape components.

### 3.8 Load line certificates

The form of the load line certificate is to be as specified by the National Regulator.

*Note* A certificate issued in accordance with Marine Order 507 accompanied by a Load line Conditions of Assignment Report and an Initial Load Line Survey Report may be required.

## Chapter 4 Class 1, 2 and 3 vessels less than 24 m measured length

(Required outcomes: Chapter 2)

### 4.1 Application

- (1) This chapter contains the deemed to satisfy solutions for Class 1, 2 and 3 vessels less than 24 m in measured length in all operational areas.
- (2) However, for a Class 1 or 2 vessel, 24 m or more in load line length, the deemed to satisfy solutions in Chapter 3 or Chapter 5 of this Section apply, as applicable to the vessel.

*Note 1* A vessel with measured length approaching 23 m should have its length assessed to Regulation 3 of the ICLL to ensure that it is not required to comply with either Chapter 3 or 5 of this Section. See Clause 2.1 for additional clarification.

*Note 2* For Class 3 vessels, 24 m or more in measured length, the deemed to satisfy solutions in Chapter 6 of this Section apply.

### DEEMED TO SATISFY SOLUTIONS WATERTIGHT INTEGRITY

#### 4.2 Weather decks and superstructure

- (1) The vessel may be fitted with a watertight weather deck or a combination of a partial weather deck and a weathertight superstructure or deckhouse, complying with the requirements of 4.3 and 4.4.
- (2) A vessel that is not arranged in accordance with subsection (1) above and falls within the definition of an open vessel in NSCV Section C6A, must meet all performance requirements for open vessels contained in NSCV Part B and NSCV Section C6.

*Note* A vessel not arranged in accordance with subsection (1) will likely be an open vessel under NSCV Part B and Section C6A.

- (3) All openings in an exposed weathertight deck must:
  - (a) have coamings of at least the height specified in Tables 2 to 5; and
  - (b) be provided with efficient, rapid, and weathertight means of closing.
- (4) Freeing ports and scuppers must be fitted as necessary and must be capable at all times of rapid drainage, under all weather conditions, in accordance with clause 4.16 and 4.17.

*Note 1* NSCV Part C3 contains requirements for structural strength.

*Note 2* Where superstructures and deckhouses do not comply with the weathertight requirements of clause 4.2, they will not be considered to be enclosed.

#### 4.3 Recesses

- (1) Any recess in the weather deck must be of weathertight construction and must be self-draining under all anticipated operating conditions and heel and trim of the vessel. The rapid drainage requirements of clause 4.16 and 4.17 apply to recesses in the weather deck.
- (2) Alternative arrangements for the size and drainage of a recess may be accepted by National Regulator provided it can be demonstrated that:
  - (a) with the vessel upright and at its deepest draft, the recess drains from a swamped condition within 2 minutes for vessels less than 12 m in length, and within 3 minutes for vessels 12 m to less than 24m in length; or
  - (b) the cockpit or recess complies with ISO 11812 *Small Craft – Watertight and Quick Draining Cockpits*.

*Note* See Table 7 for a simplified rapid drainage assessment method.

- (3) For determining appropriate drainage arrangements, a minimum of 10° of heel and 5° of trim should be used for the anticipated operating conditions.
- (4) Well deck vessels and cockpit vessels are vessels containing recesses, and must comply with the requirements of this clause 4.3. Cockpit decks must be located as high above the deepest loaded waterline as is practicable.

*Note 1* If the freeboard to the weather deck of a well deck vessel, measured from the deepest loaded waterline, is less than that required in NSCV Section C6, the vessel will be considered as an open vessel and restricted to operational areas in accordance with NSCV Part B.

*Note 2* NSCV Section C6 contains standards on minimum freeboard and height requirements for cockpit decks. Well deck and cockpit vessels are also defined in NSCV Section C6A.

#### 4.4 Flush decked barges

- (1) A flush decked vessel must be watertight, must not have bulwarks that form wells and must be designed to promote drainage.
- (2) The minimum freeboard to the weather deck of a flush decked vessel, measured from the deepest loaded waterline, must be in accordance with either Table 1 or NSCV Subsection C6A, whichever is greater

*Note* For typical types of decking arrangements for domestic commercial vessels – see Schedule 2 of NSCV Part B.

*Example* Barges are a typical example of a flush decked vessel.

**Table 1 Minimum freeboard of flush decked vessels**

Vessel Length <sup>1</sup>	Minimum freeboard
≤ 6 m	150 mm
12 m	250 mm
24m	300 mm

1 Intermediate lengths >6m to <12m and >12m to <24m must be interpolated.

#### 4.5 Collared vessels

- (1) **Hull drainage** – a collared vessel must be equipped with at least one drain plug or sock, and one bailing system.
- (2) **Hull/bilge drainage** – for collared vessels fitted with an integral closed hull or cockpit assembly which is not at least 90% filled with closed-cell foam or equivalent, facilities must be provided for draining the interior part of the hull (bilge). Means to prevent the accidental discharge of oily waste must be provided.
- (3) **Cockpit self-draining** – a collared vessel must have adequate and suitable drainage in accordance with clause 4.17 or one of the following standards that is applicable to the type and operations of the vessel:
  - (a) ISO 6185-3:2014 *Inflatable boats – Part 3: Boats with a hull length less than 8m with a motor rating of 15 kW and greater*;
  - (b) ISO 6185-4:2014 *Inflatable boats – Part 4: Boats with a hull length of between 8m and 24m with a motor power rating of 15 kW and greater*; or
  - (c) ISO 11812: 2015 *Small craft – Watertight cockpits and quick-draining cockpits*.

*Note 1* For drain plug requirements – see clause 4.12.

*Note 2* A collared vessel must have the minimum freeboard specified in NSCV Section C6.

#### 4.6 Watertight and weathertight doors

- (1) All access openings in bulkheads of enclosed superstructures, and other structures through which water could enter and endanger the vessel, must be fitted with doors permanently attached to the bulkhead, framed and stiffened so that the whole structure is of equivalent strength to the unpierced structure, and weathertight when closed.
- (2) The door must be secured by gaskets and clamping devices, or other equivalent means, which must be permanently attached to the bulkhead or to the doors themselves and capable of being operated from both sides of the bulkhead.
- (3) Where there are deckhouses or superstructures within which there is access to below the deck level, the height of door sills must not be less than the height prescribed in Tables 2 to 5.
- (4) One wheelhouse door, located in the aft or protected area of the wheelhouse, must be a sliding type on Class 3 vessels 12 m or more in measured length. For enclosed superstructures, the sliding door must be weathertight. The height of the door sill must not be less than the height prescribed in Tables 2 to 5.
- (5) The design and construction of watertight and weathertight doors on the vessel must comply with one of the following standards that is applicable to the type and operations of the vessel:
  - (a) ISO 12216 2002-06 (E) *Small craft – Windows, portlights, hatches, deadlights and doors – strength and watertightness requirements*;
  - (b) ASTM F1069-19 *Standard Specification for Doors, Watertight, Gastight/Airtight and Weathertight, Individually Dogged, for Marine Use*;
  - (c) ISO 17940:2015 *Ships and marine technology — Hinged watertight doors*;
  - (d) the rules of a Recognised Organisation covering watertight and weathertight doors; or
  - (e) for <12 m vessels: ABYC H-3 *Exterior Windows, Windshields, Hatches, Doors, Port Lights, and Glazing Materials*.

*Note 1* NSCV Subsection C6B contains requirements for watertight doors and access and inspection penetrations.

*Note 2* International standards may be based on operational areas or operational conditions which differ to those contained in NSCV Part B. In these cases, the standard must be applied so that it is at least equivalent to the design environmental parameters in NSCV Part B.

- (6) The doors must be assessed, installed and tested in accordance with Chapter 7.

#### 4.7 Hatches and coamings

- (1) The height above deck of the coaming of hatchways, and of the permanent weathertight sills of openings in deckhouse or companionways, which give access into spaces below the weather deck, must be in accordance with Tables 2 to 5.
- (2) Openings in deckhouses and companionways which give access into spaces below the weather deck and which are located in cockpits, wells or in position 1, must be fitted with weathertight doors.
- (3) A cover to a hatchway must be hinged, sliding, or permanently secured by other equivalent means to the structure of the vessel, and must be provided with sufficient locking devices to enable it to be positively secured in the closed position.

- (4) A hatchway with a hinged cover which is located in the forward quarter of the vessel, must have the hinges fitted to the forward side of the hatch, to protect the opening from boarding seas, except where it is not possible to do so because of the shape of the hatch or its moulding.
- (5) A hatch which cannot comply with subsection (4) due to the shape of the hatch or its moulding, must be secured closed at sea, and must be provided with a suitable blank. This does not apply to small technical spaces drained directly overboard by gravity alone.

*Example of small technical space* Anchor lockers.

- (6) Hatches used for escape purposes must be:
  - (a) capable of being opened from both sides;
  - (b) readily identifiable and either:
    - (i) have the text “MUST BE CLOSED AT SEA” and “ESCAPE - DO NOT OBSTRUCT” in a contrasting colour that is highly visible; or
    - (ii) have IMO signage complying with IMO Resolution A.1116(30) and ISO 24409, with a minimum size of 10 cm x 30 cm. The applicable signage signs are “ESCAPE HATCH”, “EMERGENCY EXIT KEEP CLEAR” and “THIS HATCH MUST BE KEPT CLOSED AT SEA”;
  - (c) easy and safe to use, having due regard to their position; and
  - (d) when located within the forward quarter of a vessel’s length, must be forward hinged.

*Note* See NSCV Section C1 for required markings of escape components.

- (7) The design and construction of hatches on the vessel must comply with one of the following standards that is applicable to the type and operations of the vessel:
  - (a) ISO 12216 2002-06 (E) *Small craft – Windows, portlights, hatches, deadlights and doors – strength and watertightness requirements*;
  - (b) ISO 5778:1998 *Ships and marine technology — Small weathertight steel hatches*;
  - (c) the rules of a Recognised Organisation covering watertight and weathertight hatches; or
  - (d) for <12 m vessels: *ABYC H-3 Exterior Windows, Windshields, Hatches, Doors, Port Lights, and Glazing Materials*.
- (8) The hatches must be assessed, installed and tested in accordance with Chapter 7.

#### **4.8 Ventilation**

- (1) Ventilators in positions 1 or 2 to spaces below the freeboard deck, decks or enclosed superstructure, must be of adequate strength, with a readily available means of weathertight closure and coaming heights as specified in Tables 2 to 5.
- (2) However, a ventilator may be without a means of weathertight closure provided it does not downflood at angles of heel less than 40 degrees in all conditions of loading. Designers using this option must prove within stability calculations and booklets the minimum angle of heel can be obtained before progressive downflooding occurs.

*Note* Ventilators with means of closing watertight may have a downflooding angle that is less than 40 degrees heel.

- (3) Ventilators should be located as far inboard as practicable, and the height above the deck of the ventilator opening should be sufficient to prevent the ready admission of water when the vessel is heeled. The point of flooding through openings of ventilators

and air pipes that penetrate the effective watertight envelope must not be located below the freeboard deck.

- (4) Ventilators must have coamings of sufficient height with respect to their location to comply with the protection from downflooding requirements of NSCV Subsection C6A and any applicable requirements of NSCV Section C4.

#### **4.9 Weathertight and watertight closing components**

- (1) Tables 2 to 5 contain the minimum allowable heights of openings, coamings and sills.
- (2) Where a hatch is, under the applicable table, permitted to be flush:
  - (a) there must be a watertight seal;
  - (b) the opening should be dogged or secured at all edges;
  - (c) spaces accessible through the hatchway must be serviced by a bilge pump and bilge alarm;
  - (d) the hatch must not be used as a dedicated passenger access and must not be necessary for general operations (where access is required to the space at sea);
  - (e) if the hatch provides the single means of access to an unmanned machinery space, then the vessel must have a second separated machinery space;
  - (f) the hatch must not be of a width greater than half the beam of the vessel;
  - (g) if access is required through the hatch for activation of firefighting or bilge systems, then a remote means of activation from outside the space must be provided; and
  - (h) the hatch must be marked on both sides of the hatch cover with the following text: "MUST BE CLOSED AT SEA".
- (3) Watertight and weathertight components that serve multiple functions must comply with the most onerous requirements.

**Table 2 Watertight and weathertight components for vessels length less than 12 m in offshore waters**

Watertight and weathertight components	Minimum height requirements for vessels <12 m in A, B Extended, B and C operational areas			
	Position 1	Position 2	No direct access leading below the weather deck	Normally closed at sea (regardless of position)
Shell openings (non-opening portlights, windows and other miscellaneous small openings)	500 mm above the deepest loaded waterline			
Escape hatch coaming heights	<p>Must be located a minimum height of 800 mm above the deepest loaded waterline or have a minimum coaming height of 200 mm and in both cases must meet the requirements of clause 4.7(6). Adequate protection must be provided for escape purposes in all foreseeable environmental conditions if using a flush hatch.</p> <p><i>Note</i> Any escape hatch will need to consider the installation location and the risk of boarding seas in all environmental conditions of operation, large amounts of green water will impede escape and place the vessel at flooding risk. Other deck hardware and fittings also need to be considered to allow for a person to safety and swiftly escape unimpeded.</p>			
Machinery access hatch coaming heights	200 mm	150 mm	Flush	Flush
Other hatches	150 mm	Flush	Flush	Flush
Door and access sill heights to enclosed spaces	200 mm	150 mm	Minimum to provide seal <sup>1</sup>	Minimum to provide seal
Ventilator heights	600 mm	375 mm	375 mm	--
Air Pipe heights	600 mm	375 mm	375 mm	--

<sup>1</sup> Minimum to provide a seal that is weathertight.



**Table 3 Watertight and weathertight components for vessels less than 12 m in sheltered waters**

Watertight and weathertight components	Minimum height requirements for vessels <12 m in D and E operational areas			
	Position 1	Position 2	No direct access leading below	Normally closed at sea (regardless of position)
Shell openings (non-opening portlights, windows and other miscellaneous small openings)	200 mm above the deepest loaded waterline			
Escape hatch coaming heights	<p>Must be located a minimum of 500 mm above the deepest loaded waterline or must have a minimum coaming height of 100 mm and in both cases must meet the requirements of clause 4.7(6). Adequate protection must be provided for escape purpose in all foreseeable environmental conditions if using a flush hatch.</p> <p><i>Note</i> Any escape hatch will need to consider the installation location and the risk of boarding seas in all environmental conditions of operation, large amounts of green water will impede escape and place the vessel at flooding risk. Other deck hardware and fittings also need to be considered to allow for a person to safety and swiftly escape unimpeded.</p>			
Machinery access hatch coaming heights	100 mm	100 mm	Flush	Flush
Other hatches	100 mm	Flush	Flush	Flush
Door and access sill heights to enclosed spaces	100 mm	Minimum to provide seal <sup>1</sup>		
Ventilator heights	375 mm			--
Air Pipe heights	375 mm			--

<sup>1</sup> Minimum to provide a seal that is weathertight.

**Table 4 Watertight and weathertight components for vessels of at least 12 m and less than 24 m in offshore waters**

Watertight and weathertight components	Minimum height requirements for vessels 12 m – < 24 m in A, B Extended, B, and C operational areas			
	Position 1	Position 2	No direct access leading below	Normally closed at sea (regardless of position)
Shell openings (non-opening portholes, windows and other miscellaneous small openings)	500 mm above the deepest loaded waterline			
Escape hatch coaming heights	<p>Must be located a minimum of 1000 mm above the deepest loaded waterline or have a minimum coaming height of 300 mm and in both cases must meet the requirements of clause 4.7(6). Adequate protection must be provided for escape purpose in all foreseeable environmental conditions if using a flush hatch.</p> <p><i>Note</i> Any escape hatch will need to consider the installation location and the risk of boarding seas in all environmental conditions of operation, large amounts of green water will impede escape and place the vessel at flooding risk. Other deck hardware and fittings also need to be considered to allow for a person to safety and swiftly escape unimpeded.</p>			
Machinery access hatch coaming heights	300 mm	200 mm	Flush	Flush
Other hatches	200 mm	Flush	Flush	Flush
Door and access sill heights to enclosed spaces	300 mm	200 mm	Minimum to provide seal <sup>1</sup>	Minimum to provide seal
Ventilator heights	600 mm	375 mm	375 mm	--
Air Pipe heights	760 mm	450 mm	450 mm	--

<sup>1</sup> Minimum to provide a seal that is weathertight.

**Table 5 Watertight and weathertight components for vessels at least 12 m and less than 24 m in sheltered waters**

Watertight and weathertight components	Minimum height requirements for vessels 12 m – < 24 m in D and E operational areas			
	Position 1	Position 2	No direct access leading below	Normally closed at sea (regardless of position)
Shell openings (non-opening portholes, windows and other miscellaneous small openings)	200 mm above the deepest loaded waterline			
Escape hatch coaming heights	Must be located a minimum of 500 mm above the deepest loaded waterline or have a minimum coaming height of 150 mm and in both cases must meet the requirements at clause 4.7(6). Adequate protection must be provided for escape purpose in all foreseeable environmental conditions if using a flush hatch. <i>Note</i> Any escape hatch will need to consider the installation location and the risk of boarding seas in all environmental conditions of operation, large amounts of green water will impede escape and place the vessel at flooding risk. Other deck hardware and fittings also need to be considered to allow for a person to safety and swiftly escape unimpeded.			
Machinery access hatch coaming heights	200 mm	100 mm	Flush	
Other hatches	100 mm	Flush	Flush	Flush
Door and access sill heights to enclosed spaces	200 mm	100 mm	Minimum to provide seal <sup>1</sup>	
Ventilator heights	600 mm	375 mm		--
Air Pipe heights	600 mm	375 mm		--

<sup>1</sup> Minimum to provide a seal that is weathertight.

#### 4.10 Air Pipes

- (1) Air pipes must be fitted to prevent air locks and over or under pressurisation in compartments such as tanks, voids, cofferdams and duct spaces.
- (2) Air pipes extending above the deck must be of adequate strength and must be provided with weathertight closing devices.  
*Example* Efficient means of closing an air pipe weathertight include weighted flaps and ball float heads.
- (3) Air pipes must have a minimum height above the deck in accordance with Tables 2 to 5, as well as sufficient height above the deck to prevent inadvertent downflooding when the vessel is heeled.  
*Note* NSCV Section C6 contains standards for downflooding.
- (4) Air pipes must be designed to resist breach or deformation arising from loads on deck

in normal and abnormal conditions of operation. Air pipes must be constructed of a material that is compatible with the vessel's construction material to limit galvanic corrosion. Air and sounding pipes must:

- (a) be readily identifiable as to their purpose and have a name identified to the upper end of the pipe; and
  - (b) be well protected where they are situated in areas where mechanical damage may occur.
- (5) Air pipes must be led to exposed decks unless the air pipe is from a void space, in which case they may lead to a space that is adequately ventilated.

#### **4.11 Materials for seacocks, through-hull fittings, valves and associated piping systems**

- (1) A valve or similar fitting attached to the side of the vessel below the waterline, within a machinery space or other high fire risk area, or to essential system piping, must be of steel, bronze, copper, or other non-brittle fire resistant material.
- (2) Seacocks, valves, through-hull fittings and associated piping must comply with one of the following standards:
  - (a) ISO 9093-1 *Small craft – Seacocks and through-hull fittings – Part 1: Metallic;*
  - (b) ISO 9093-2 *Small craft – Seacocks and through-hull fittings – Part 2: Non-metallic;* or
  - (c) ABYC H-27 *Seacocks, thru-hull fittings, and drain plugs.*

*Note* Non-metallic fittings are generally not suitable when a fire resistant material is required or in an area of high use that is susceptible to being walked on or crushed. Use metallic fittings on fire boundaries and when fittings are close to or adjacent to machinery equipment within maintenance envelopes.

#### **4.12 Bungs, drain plugs and docking plugs**

- (1) Small penetration closures that can only be accessed when the vessel is slipped must comply with one of the following standards:
  - (a) ABYC H-27 *Seacocks, Thru-hull fittings, and drain plugs;*
  - (b) ISO 9093-1 *Small craft – Seacocks and through-hull fittings – Part 1: Metallic;* or
  - (c) ISO 9093-2 *Small craft – Seacocks and through-hull fittings – Part 2: Non-metallic.*
- (2) The use of dissimilar metals in small penetration closures must be considered at the design stage and avoided where possible. If avoidance is not possible, dissimilar metal should be isolated to the extent possible.
- (3) Small penetration closures must have a retaining device (a second means of retention that is not a thread).

*Note* NSCV Subsection C5A contains standards for bilge requirements.

#### **4.13 Portlights and windows**

- (1) The design and construction of side scuttles, windows and skylights on the vessel must comply with one of the following standards that is applicable to the type and operations of the vessel:
  - (a) ISO 12216 2002 *Small craft — Windows, portlights, hatches, deadlights and doors — Strength and watertightness requirements;*

- (b) the rules of a Recognised Organisation covering portlights, windows and skylights; or
- (c) for <12 m vessels in operational area categories C, D or E: *ABYC H-3 Exterior Windows, Windshields, Hatches, Doors, Port Lights, and Glazing Materials*.

*Note* International standards may be based on operational areas or operational conditions which differ to those contained in NSCV Part B. In these cases, the standard must be applied so that it is at least equivalent to the design environmental parameters in NSCV Part B.

- (2) If ISO 12216 is used:
  - (a) the requirements of the ISO 12216 design category equivalent to the vessel's operational area category, as specified in Table 6, apply; and
  - (b) the additional limitations specified in Table 6 for the design category apply.

*Note* Operational area categories are defined in NSCV Part B.

- (3) The side scuttles, windows and skylights must be assessed, installed, and tested in accordance with Chapter 7.

*Note* The design and construction standard to which the side scuttles, windows and skylights are constructed may include requirements for assessment, installation and/or testing. Where those requirements are complied with, the relevant requirements of Chapter 7 will be satisfied. For example, a manufacturer or testing authority may provide evidence that a vessel window manufactured to ISO 12216 2002-06 (E) meets the standard. This evidence would be reviewed by a competent person in accordance with Chapter 7. Installation verification would then be conducted by a competent person in accordance with Chapter 7.

- (4) A portlight or window must not be fitted in the main hull below the weather deck, unless the glazing material and its method of fixing in the frame are equivalent in strength, with regard to design pressure, to that required for the structure in which it is fitted.
- (5) A portlight or window fitted in the main hull below the weather deck must be protected or recessed against impact damage.
- (6) For vessels operating in operational area categories A, B Extended, B or C, only non-opening windows with portable storm covers and fixed portlights fitted with hinged deadlights, are permitted in the in the main hull below the weather deck.
- (7) However, for vessels operating in operational area category C, opening portlights complying with subsection (8), are permitted.
- (8) For vessels in operational area categories C, D and E, opening portlights are permitted in the main hull below the weather deck provided the vessel meets the requirements for one compartment subdivision in NSCV Section C6 and provided the opening portlights are:
  - (a) located as high as practicable to the freeboard deck, and at least:
    - (i) for vessels less than 12 m in measured length: 750 mm above the deepest loaded waterline; and
    - (ii) for vessels 12 m or more in measured length: 1,000 mm above the deepest loaded waterline;
  - (b) not located in the forward quarter of the hull;
  - (c) not located in a high fire risk space;
  - (d) marked "do not open at sea"; and
  - (e) for vessels in operational area category C: fitted with hinged deadlights.
- (9) Subject to the allowances in subsection (8), the lower edge of the glass of a portlight or window must be a least the distance specified in Tables 2 to 5 above the deepest

loaded waterline in any condition of heel or trim.

- (10) Toughened safety glass or its equivalent must be used for wheelhouse windows.

**Table 6 Relationship between NSCV operational area categories and ISO 12216 design categories**

<b>NSCV Operational Area Category</b>	<b>Equivalent ISO 12216 Design Category</b>	<b>Additional limitations and notes on application</b>
A and B Extended	May not be suitable (Review the scope of ISO 12216)	The scope of ISO 12216 is not applicable to vessels used in severe conditions
B	A: Ocean	Not to operate in abnormal conditions (e.g. cyclone). Applicable to vessels designed for extended voyages where conditions experienced may exceed wind force 8 Beaufort and significant wave heights of 4 m and above.
C	B: Offshore	Not to operate in significant wave height greater than 4 m, nor wind force exceeding 8 Beaufort.
D	C: Inshore	Not to operate in significant wave height greater than 2 m, nor wind force exceeding 6 Beaufort.
E	D: Sheltered waters	Not to operate in significant wave height greater than 0.5 m. Not to operate in wind force exceeding 4 Beaufort (unless it is a sailing vessel).

*Examples of severe conditions* Lightning, hail, sudden increases in wind gusts (commonly referred to as squalls), significant wave heights, reduced visibility from fog or severe ship movements.

#### 4.14 Skylights and skylight hatches

- (1) Skylights must be of weathertight construction and should not be placed in a location where the skylight may be continuously immersed in water during the dynamic motions of the vessel.
- (2) Glazing in skylights must be thermally toughened safety glass and must be in accordance with an appropriate national or international marine standard, or the rules of a Recognised Organisation, that is applicable to the location of the skylight.
- (3) Skylights fitted in positions 1 or 2 must have suitable protection to avoid mechanical damage and, for vessels in operational area categories A, B Extended, B or C, must be provided with robust deadlights or storm covers permanently attached.
- (4) When a skylight is of an opening type, it must be provided with efficient means to secure it in the closed position.
- (5) In addition, a skylight which is provided as a means of escape must:
  - (a) be capable of being opened from both sides;
  - (b) have glazing material and its method of fixing to the frame that is the equivalent strength to the surrounding structure;

- (c) be of a minimum size required for a ball 450 mm in diameter to pass through;
- (d) be readily identifiable and either:
  - (i) have the text “MUST BE CLOSED AT SEA” and “ESCAPE - DO NOT OBSTRUCT” in a contrasting colour that is highly visible; or
  - (ii) have IMO signage complying with IMO Resolution A.1116(30) and ISO 24409, with a minimum size of 10 cm x 30 cm. The applicable signage signs are “ESCAPE HATCH”, “EMERGENCY EXIT KEEP CLEAR” and “THIS HATCH MUST BE KEPT CLOSED AT SEA”;
- (e) be easy and safe to use, having due regard to its position; and
- (f) when located within the forward quarter of a vessel’s length, be forward hinged; and
- (g) have the sill height, and meet the other requirements, of Tables 2 to 5 that apply to escape hatches.

*Note* See NSCV Section C1 for required markings of escape components.

- (6) A portable “blank” for each skylight, which can be efficiently secured in place in event of breakage of the glazing, must be carried. The blank must be of suitable material and strength sufficient for purpose.

#### 4.15 Marking of doors, mechanisms and valves

- (1) Suitable notices and signs must be provided on, or close to all doors, valves and closing appliances indicating their purpose, the procedures for operating them and any precautions to be observed.
- (2) The notices and signs must comply with one of the following standards for markings and graphical symbols, as applicable to the type of door, valve or closing appliance:
  - (a) ISO 7010:2019 *Graphical symbols - Safety colours and safety signs- Registered safety signs*;
  - (b) ISO 24409-2 *Ships and marine technology - Design, location and use of shipboard safety signs, fire control plan signs, safety notices and safety markings*;
  - (c) IMO *Safety and operating instruction for trained personnel (SIS)*, IMO Resolution A 952 (23) and IMO Resolution A 654 (16);
  - (d) IMO *Mandatory Action Signs*; or
  - (e) ABYC T-5 *Safety Signs and Labels*.

*Note 1* See clause 3.6 for an example of an IMO Mandatory Action Sign suitable for small vessels of the appropriate size.

*Note 2* NSCV Subsection C6B contains standards on door performance criteria, additional markings and indications of various type of watertight doors.

## WATER FREEING ARRANGEMENTS AND DRAINAGE

#### 4.16 Rapid drainage of cockpit, well deck or recess

*Note* The term “rapid drainage” has been used to differentiate the rapid drainage requirements from the common understanding of “self-draining” cockpits and well decks. Self-drainage requirements allow water to be drained overboard in certain conditions, but do not specify required draining speed or recess heights above the deepest loaded waterline.

- (1) Any recess in the weather deck must comply with the requirements of 4.3.
- (2) A vessel is considered to have rapid drainage if the recess bounded by the reserve buoyancy, wells or gunwales, meets the requirements of one of the following:

- (a) for vessels where the recess bottom has only one level and the recess ratio is less than half the measured length of the vessel: Table 7. This is a test method based on the maximum draining time;
- (b) ISO 11812 *Small craft – Watertight or quick-draining recesses and cockpits*; or
- (c) the recess has freeing ports sized and arranged in accordance with the requirements of 4.17 and scupper drains in accordance with 4.18, as well as the minimum freeboard indicated as  $H_B$  min in Table 7.

*Note* 4.16 (2)(b) and (c) allow for an optimised design. 4.16(2)(a) is a simplified method only.

- (3) However, for subsection (2)(c):
  - (a) on sailing vessels where the average height of the bulwark over its length does not exceed 150 mm, freeing ports are not required, however suitable drainage arrangements in accordance with 4.18 are required; and
  - (b) for vessels in sheltered waters, the minimum freeing port area and scupper drain area may be reduced by up to 50%.

CONSULTATION DRAFT



**Table 7 Simplified rapid drainage assessment method for vessels where the recess bottom has only one level and the recess ratio is less than 0.5**

Vessel length	Operational Area Category	H <sub>B</sub> min <sup>1</sup>	Maximum draining time <sup>2, 5</sup>
≤7.5 m	A and B Extended	0.150 m	2 minutes <sup>3</sup>
	B	0.100 m	
	C <sup>4</sup>		
	D <sup>4</sup> and E <sup>4</sup>	0.075 m	5 minutes <sup>3</sup>
>7.5 m to ≤12 m	A and B Extended	0.150 m	3 minutes <sup>3</sup>
	B	0.120 m	
	C <sup>4</sup>		
	D <sup>4</sup> and E <sup>4</sup>	0.100 m	5 minutes <sup>3</sup>
>12 m to ≤18 m	A and B Extended	0.200 m	3 minutes <sup>3</sup>
	B	0.180 m	5 minutes <sup>3</sup>
	C		
	D and E	0.150 m	
>18 m to 24 m	A and B Extended	0.260 m	3 minutes <sup>3</sup>
	B	0.240 m	5 minutes <sup>3</sup>
	C		
	D and E	0.200 m	

1 H<sub>B</sub> min is the minimum height of the recess bottom above the deepest loaded waterline.

2 There must be a minimum of two drains fitted to the recess, with a minimum diameter of at least 25 mm (one port and one starboard). Drains with other cross-sectional shapes must have an internal cross-sectional area of at least 500 mm<sup>2</sup>, and an internal minimum dimension of 20 mm.

3 The maximum draining time means that all recesses must self-drain in less than the time mentioned above and must have no more than 100 mm height of residual water.

4 Open vessels can choose to comply with the bilge pump requirements of NSCV C5A. H<sub>B</sub> min does not apply to open vessels.

5 Grids or systems preventing loose objects from falling into the draining system must consider that a grid with small holes is more prone to being clogged than the drain itself. Table 7 can only be used if:

- a) the minimum passage dimension inside any part of these devices has at least a section of 125mm<sup>2</sup> (or a diameter of 12mm); and
- b) the total entry cross section is at least 1.5 times the internal cross-section of the drain.

#### 4.17 Freeing ports

*Note* Freeing ports are openings in the bulwarks on the open deck to allow water to drain directly overboard. The purpose of a freeing port is to rapidly drain large quantities of water from a deck.

- (1) Decks that form wells must be provided with freeing ports that comply with the following:
  - (a) for vessels less than 12 m in measured length:
    - (i) the minimum freeing port area must not be less than 90 cm<sup>2</sup> for every 1 m<sup>3</sup> of water that may be entrapped within bulwarks or wells; and
    - (ii) there must be a minimum of two ports fitted (one port and one starboard). Ports may only be fitted in the transom (one port and one starboard) on vessels where under all foreseeable conditions water will drain when the vessel is at rest;
  - (b) for vessels 12 m or more in measured length:
    - (i) the minimum freeing port area must not be less than the area (A) determined under the following equation. The area (A) may include openings cut in the transom; and

$$A = \frac{(1.0 + 3.5h) \times m \times h}{100}$$

Where: A = minimum freeing port area on each side of the vessel in square metres

m = length of well in metres

h = height of bulwark in metres

- (ii) freeing ports must be situated in the lower third of the bulwark height, as close to the deck as practicable; and
  - (c) freeing ports greater than 230 mm in depth must be fitted with bars spaced not more than 230 mm apart. When a shutter or flap is fitted to a freeing port it must have sufficient clearance to prevent jamming and any hinges should have pins or bearings of materials resistant to corrosion.
- (2) If flaps are fitted to freeing ports, they must open outward, without resistance, from the bulwark to a position no less than 90° to the vertical plane of the bulwark.
  - (3) Where cargo or equipment is to be stowed on deck, the stowage arrangements must not impede the free flow of water from the deck.

#### 4.18 Scuppers and discharges

*Note 1* Scuppers are a system of gravity deck drains and connected piping leading from scupper wells to the side shell of the vessel. The purpose of a scupper is to self-drain small quantities of water such as rain or spray.

*Note 2* NSCV Subsection C5A contains standards and requirements for inlets and discharge valves, and discharge and inlet piping material characteristics, including thickness.

- (1) Scuppers must provide effective drainage to decks and enclosed spaces. They must be located where they remain effective in any attitude of vessel trim between zero and 5 degrees, and between zero and 15 degrees heel. The combined cross-sectional area of all the scuppers must be at least 700 mm<sup>2</sup> per square metre of cockpit deck area.

*Note* Often the freeing ports on small vessels, when designed following clause 4.17(1)(a), can cover the minimum area required for a scupper as well as the freeing port, if correctly sized to account for both requirements.

- (2) Scuppers on weather portions of decks and scuppers leading from superstructures or deckhouses not provided with weathertight closing appliances must be led overboard. Scuppers from spaces below the freeboard deck or spaces within closed superstructures, may be led to bilges.
- (3) An opening below the weather deck must be provided with a positive means of closure. The number of inlets and discharges should be kept to an operational minimum.
- (4) When an opening is for the purpose of a discharge below the waterline it should be fitted with a seacock, valve or other effective means of closure internally as close to the vessel's side as possible, and which is either remotely operated or readily accessible in an emergency. Discharge lines should also have an automatic non-return valve.
- (5) Inlet and discharge pipes from marine toilets should be provided with shell fittings as required by clause 4.11. Anti-syphon measures should be provided when the rim of a marine toilet is less than 300 mm above the deepest waterline of the vessel, unless otherwise indicated by manufacturer's recommendations.

*Note* NSCV Subsection C5A contains bilge level alarm requirements.

## **RESERVE BUOYANCY AND PREVENTION OF OVERLOADING**

### **4.19 Maximum displacement**

The maximum displacement for a vessel is the lesser of that determined in accordance with each of the following criteria that is relevant to the vessel:

- (a) that determined in accordance with the applicable criteria of NSCV Section C6;
- (b) freeboards assigned within this NSCV Section C2; and
- (c) the maximum displacement assumed for the purpose to determine hull scantlings in NSCV Section C3.

### **4.20 Freeboard Mark**

- (1) Vessels of less than 7.5 m in measured length must be provided with a stability notice or placard which complies with the requirements of NSCV Section C6C Annex J and which is displayed in the operating compartment of the vessel in a prominent position.
- (2) Vessels of 7.5m and greater but less than 12 m in measured length must be provided with:
  - (a) a freeboard mark in accordance with Annex A which shows the freeboard determined in accordance with 4.19; or
  - (b) where a freeboard mark required in (a) cannot be practicably marked or seen on the hull, a stability notice or placard which complies with the requirements of NSCV Section C6C Annex J and which is displayed in the operating compartment of the vessel in a prominent position.
- (3) Vessels 12 m or more in measured length must be provided with a freeboard mark in accordance with the requirements of Annex A which shows the freeboard determined in accordance with 4.19.

*Note* NSCV Subsection C6B contains requirements and standards for subdivision load lines.

## Chapter 5 Class 1 and 2 vessels 24 m or more in load line length in sheltered waters

(Required outcomes: Chapter 2)

### 5.1 Application

This chapter contains the deemed to satisfy solutions for Class 1D, 1E, 2D and 2E vessels 24 m or more in load line length.

### DEEMED TO SATISFY SOLUTIONS

#### 5.2 Modifications to the International Convention on Load Lines (ICLL) for sheltered water vessels

- (1) The vessel must comply with the ICLL subject to the:
  - (a) specifications, modifications and additional requirements contained in Chapter 3; and
  - (b) modifications contained in Table 8 and clauses 5.3 and 5.4.

*Note 1* Table 8 reduces the ICLL requirements commensurate with the risks of the reduced environmental conditions and distance from land.

*Note 2* Annex B provides a summary of all the relevant provisions of the ICLL for domestic commercial vessels subject to Chapter 3. Annex B is also relevant to vessels subject to this Chapter 5, however the modifications in Table 8 and clauses 5.3 and 5.4 apply in addition to the requirements at Annex B.

- (2) For the purposes of subsection (1), the ICLL applies to the vessel as if the vessel was a vessel engaged on an international voyage.

*Note 1* In accordance with Marine Order 507, a Recognised Organisation or an Accredited Marine Surveyor with the appropriate accreditation may carry out load line surveys on domestic commercial vessels (in accordance with the accreditation category and any conditions of accreditation).

*Note 2* Vessels subject to this Chapter 5 will either be assigned a freeboard mark or require a subdivision load line as required by NSCV Section C6.

*Note 3* Vessels over a certain length are required to be built to the rules of a Recognised Organisation for the construction (hull), machinery and electrical aspects of the vessel.

**Table 8 Modifications to the International Convention on Load Lines for sheltered water vessels**

ICLL Annex I Chapter & Regulation number	Title	Modification
I/4	Deck line	Must be in accordance with Annex A of this Section.
I/5	Load Line Mark	A load line mark is not required provided the vessel displays a freeboard mark in accordance with Annex A.
I/6	Lines to be used with the Load Line Mark	For non-load line and non-subdivision load line vessels, a load line mark is not required provided the vessel displays a freeboard mark in accordance with Annex A.

ICLL Annex I Chapter & Regulation number	Title	Modification
I/9	Verification of marks	For non-load line vessels, a Load Line Certificate is not required. Accredited marine surveyor or Recognised Organisation verification is required for freeboard marks.
<b>Conditions of assignment of freeboard II/12</b>	Doors	The height above the deck of sills in doorways of deckhouses or superstructures on the weather deck, from the inside of which there is direct access to spaces below, must not be less than: <ul style="list-style-type: none"> <li>- for position 1 – at least 300 mm above the deck; and</li> <li>- for position 2 – at least 150 mm above the deck,</li> </ul> unless otherwise approved by the National Regulator.
II/14-1	Hatchway coamings	The hatchway coaming height above the deck must be at least the following: <ul style="list-style-type: none"> <li>- for position 1 – at least 300 mm above the deck; and</li> <li>- for position 2 – at least 150 mm above the deck.</li> </ul>
II/16	Hatchways closed by weathertight covers of steel or other equivalent material fitted with gaskets and clamping devices	For hatches which are: <ul style="list-style-type: none"> <li>- situated within the mid half beam of the vessel;</li> <li>- of a width less than half the beam of the vessel; and</li> <li>- closed with efficient weathertight covers of steel or other equivalent material fitted with gaskets and clamping devices and capable of being rapidly closed and battened down,</li> </ul> the National Regulator may approve: <ul style="list-style-type: none"> <li>- the coamings of the hatchways being a height less than that specified in regulation 16 the ICLL; or</li> <li>- the coamings for the hatchways being omitted.</li> </ul>
II/18	Miscellaneous openings in freeboard and superstructure decks	Sill heights required under ICLL Regulation 18(4) may be modified as follows: <ul style="list-style-type: none"> <li>- for position 1 – at least 300 mm above the deck; and</li> </ul>

ICLL Annex I Chapter & Regulation number	Title	Modification
		<ul style="list-style-type: none"> <li>- for position 2 – at least 150 mm above the deck.</li> </ul> <p>Sill heights required under 18(5) maybe modified as follows:</p> <ul style="list-style-type: none"> <li>- at least 150 mm above the deck.</li> </ul> <p>Sill heights required under ICLL Regulation 18(6) maybe modified as follows:</p> <ul style="list-style-type: none"> <li>- at least 300 mm above the deck.</li> </ul>
II/19	Ventilators	<p>Ventilators are not required to be fitted with closing arrangements where the coamings of the ventilators:</p> <ul style="list-style-type: none"> <li>- for position 1 – extend to more than 2,300 mm above the deck; and</li> <li>- for position 2 – extend to more than 1,200 mm above the deck.</li> </ul> <p>Ventilators with coamings that are below these heights must be fitted with a closing device. Where a ventilator is fitted with a closing device, the coaming heights may be reduced to:</p> <ul style="list-style-type: none"> <li>- for position 1 – 760 mm above the deck; and</li> <li>- for position 2 – 450 mm above the deck.</li> </ul>
II/21	Cargo ports and other similar openings	<p>The lower edge of an opening referred to in ICLL Regulation 21(1) must not be below 500 mm from the deepest loaded waterline, as clearly identified by the freeboard or load line mark.</p>
II/22	Scuppers, inlets and discharges	<p>The requirement in ICLL Regulation 22(4) may be modified as follows:</p> <ul style="list-style-type: none"> <li>- Scuppers and discharges pipes originating at any level and penetrating the shell either more 225 mm below the freeboard deck or less than 300 mm above the summer freeboard mark, must be provided with a non-return valve at the shell.</li> </ul>
II/24	Freeing ports	<p>Where bulwarks in the weather portion of a freeboard deck form wells, and the sheer in the way of the well is standard or greater than standard, the minimum freeing port area required under ICLL Regulation 24(1), on each side of the vessel, in each well, must be:</p>

ICLL Annex I Chapter & Regulation number	Title	Modification																
		<p>(a) where the length of the well is 20 m or greater, obtained by the following formula; or</p> <p style="text-align: center;"><i>Freeing port area = 0.07 x l square metres</i></p> <p style="text-align: center;">Where: l = length of well in metres</p> <p>(b) where the length of the well is less than 20 m, obtained from the following table:</p> <table border="1" data-bbox="772 674 1385 1178"> <thead> <tr> <th>Length of well (metres)</th> <th>Freeing port area (for each bulwark, in square metres)*</th> </tr> </thead> <tbody> <tr><td>2.5</td><td>0.28</td></tr> <tr><td>5.0</td><td>0.52</td></tr> <tr><td>7.5</td><td>0.72</td></tr> <tr><td>10.0</td><td>0.90</td></tr> <tr><td>12.5</td><td>1.07</td></tr> <tr><td>15.0</td><td>1.21</td></tr> <tr><td>17.5</td><td>1.32</td></tr> </tbody> </table> <p>*The freeing port area for intermediate lengths of well must be determined by interpolation.</p> <p>The minimum freeing port area may include openings cut in the transom.</p>	Length of well (metres)	Freeing port area (for each bulwark, in square metres)*	2.5	0.28	5.0	0.52	7.5	0.72	10.0	0.90	12.5	1.07	15.0	1.21	17.5	1.32
Length of well (metres)	Freeing port area (for each bulwark, in square metres)*																	
2.5	0.28																	
5.0	0.52																	
7.5	0.72																	
10.0	0.90																	
12.5	1.07																	
15.0	1.21																	
17.5	1.32																	
<b>Freeboards III/28</b>	Freeboard tables	<p>Barges, lighters and similar vessels which have a completely enclosed upper deck, as well as open vessels which have watertight hatch coamings of standard height, may comply with the minimum freeboard contained in Table 8.1.</p> <p style="text-align: center;"><b>Table 8.1</b></p> <table border="1" data-bbox="772 1597 1385 2022"> <thead> <tr> <th>Length (m)</th> <th>Freeboard (mm)</th> </tr> </thead> <tbody> <tr><td>&lt;24</td><td>150</td></tr> <tr><td>24</td><td>160</td></tr> <tr><td>30</td><td>200</td></tr> <tr><td>36</td><td>240</td></tr> <tr><td>42</td><td>283</td></tr> <tr><td>48</td><td>336</td></tr> <tr><td>54</td><td>392</td></tr> </tbody> </table>	Length (m)	Freeboard (mm)	<24	150	24	160	30	200	36	240	42	283	48	336	54	392
Length (m)	Freeboard (mm)																	
<24	150																	
24	160																	
30	200																	
36	240																	
42	283																	
48	336																	
54	392																	

ICLL Annex I Chapter & Regulation number	Title	Modification	
		66	527
		72	603
		78	680
		84	768
		90	860

## RESERVE BUOYANCY AND PREVENTION OF OVERLOADING

### 5.3 Maximum displacement

The maximum displacement for a vessel is the lesser of that determined in accordance with each of the following criteria that is relevant to the vessel:

- (a) that determined in accordance with the applicable criteria of NSCV Section C6;
- (b) NSCV Section C2 requirements for freeboards contained in Table 8.1; and
- (c) the maximum displacement assumed for the purpose to determine hull scantlings in NSCV Section C3.

### 5.4 Freeboard mark

Where a vessel is required under Table 8 to have a freeboard mark, it must be:

- (a) marked clearly on each side of the vessel in accordance with the requirements of Annex A; and
- (b) assigned in accordance with the maximum displacement determined at 5.3.

*Note* NSCV Subsection C6B contains requirements and standards on subdivision load lines.



## Chapter 6 Class 3 vessels 24 m or more in measured length

(Required outcomes: Chapter 2)

### 6.1 Application

This chapter contains the deemed to satisfy solutions for Class 3 vessels 24 m or more in measured length in all operational areas.

### DEEMED TO SATISFY SOLUTIONS WATERTIGHT INTEGRITY

#### 6.2 Weather Decks

- (1) Vessels must be fitted with a watertight weather deck or a combination of a partial weather deck and a weathertight superstructure or deckhouse complying with the requirements of 6.12 and 6.13. The weather deck must extend from stem to stern and have positive freeboard throughout, in any condition of loading of the vessel. A weather deck may be stepped, recessed or raised provided the stepped, recessed or raised portion is of watertight construction.
- (2) All openings in an exposed weathertight deck must:
  - (a) have coamings of at least the height specified in Tables 9 to 12; and
  - (b) be provided with efficient, rapid, and weathertight means of closing.
- (3) Freeing ports and scuppers must be fitted to a weather deck, or partial weather deck, as necessary, and must be capable at all times of rapid drainage, under all weather conditions, in accordance with clauses 6.12 and 6.13.

#### 6.3 Recesses and hull integrity

- (1) Any recess in the weather deck must be of weathertight construction and must be self-draining under all anticipated operating conditions and heel and trim of the vessel. The rapid drainage requirements of clauses 6.12 and 6.13 apply to recesses in the weather deck.
- (2) External openings must be capable of being closed to prevent water from entering the vessel. Deck openings, which may be open during fishing operations, must normally be arranged near to the vessel's centreline.
- (3) Fish flaps on stern trawlers must be power-operated and capable of being controlled from a position on the vessel that provides an unobstructed view of the operation of the flaps.

#### 6.4 Watertight bulkheads

- (1) The number of openings in the collision bulkhead above the working deck must be reduced to the minimum compatible with the design and normal operation of the vessel. Such openings must be capable of being closed watertight.
- (2) The number of openings in watertight bulkheads must be reduced to the minimum compatible with the general arrangement and operational needs of the vessel. Openings must be fitted with watertight closing appliances designed, constructed, installed and tested in accordance with appropriate standards or rules of a Recognised Organisation. Watertight doors must be of an equivalent strength to the adjacent unpierced structure.

*Note* NSCV Subsection C6B contains requirements and standards collision bulkhead.

## 6.5 Watertight and weathertight doors

*Note* NSCV Subsection C6B contains requirements for watertight door performance and type requirements.

- (1) All access opening in bulkheads of enclosed superstructures, and other outer structures through which water could enter and endanger the vessel, must be fitted with doors permanently attached to the bulkhead or structure, which are framed and stiffened so that the whole structure is of equivalent strength to the unpierced structure and weathertight when closed.
- (2) The doors must be secured by gaskets and clamping devices which can be operated from each side of the bulkhead.
- (3) One wheelhouse door, located in the aft or protected area of the wheelhouse, must be a sliding type. For enclosed superstructures, the sliding door must be weathertight.
- (4) The height above the deck of sills in doorways, companionways, erections and machinery casings, which give direct access to positions 1 and 2, must be at least that given in Tables 9 to 12.

*Note* Doors and hatches that are part of the means of escape have additional requirements within NSCV Section C1 that must be met.

- (5) The design and construction of watertight and weathertight doors on the vessel must comply with one of the following standards that is applicable to the type and operations of the vessel:
  - (a) ISO 14884:2015 *Large yachts — Weathertight doors — Strength and weathertightness requirements*;
  - (b) ISO 6042:2015 *Ships and marine technology — Weathertight single-leaf steel doors*;
  - (c) ISO 17940:2015 *Ships and marine technology — Hinged watertight doors*; or
  - (d) the rules of a Recognised Organisation covering watertight and weathertight doors.
- (6) The doors must be assessed, installed, and tested in accordance with Chapter 7.

## 6.6 Hatchways closed by covers

- (1) The height above deck of the coaming of hatchways must be must be in accordance with Tables 9 to 12.
- (2) Hatchway openings must be kept as small as practicable and have covers which are permanently attached by hinges, or equivalent means, and are capable of being rapidly closed and battened down.
- (3) For the purpose of strength calculations, it must be assumed that hatchway covers are subjected to the weight of cargo intended to be carried on them, or to the following static loads, whichever is greater:
  - (a) 10 kN/m<sup>2</sup> for vessels 24 m in measured length;
  - (b) 17 kN/m<sup>2</sup> for vessels 100 m or more in measured length; and
  - (c) for vessels greater than 24 m and less than 100 m: loads calculated by linear interpolation of the requirements of (a) and (b).
- (4) The loads determined under subsection (3) may be reduced to not less than 75% of the load for covers to hatchways situated on the superstructure deck in a position aft of a point located 0.25L from the forward perpendicular.
- (5) Covers must be fitted with clamping devices and gaskets to ensure weathertightness, or other equivalent arrangements.

- (6) A hatchway with a hinged cover which is located in the forward quarter of the vessel must have the hinges fitted to the forward side of the hatch, to protect the opening from boarding seas, except where it is not possible to do so because of the shape of the hatch or its moulding. A hatch with the hinges on the after side of the hatch should be secured closed at sea, and be provided with a suitable blank. This does not apply to small technical spaces drained directly overboard.

*Example of a small technical space* Anchor locker.

## 6.7 Other deck openings

- (1) Where it is essential for fishing operations, flush deck scuttles of the screw, bayonet or equivalent type, and manholes, may be fitted, provided they are capable of being closed watertight. The closing devices must be permanently attached to the adjacent structure and their height above deck must comply with Tables 9 to 12.
- (2) The height above deck of the coaming of hatches used for escape purposes must be in accordance with Tables 9 to 12.
- (3) Hatches used for escape purposes must be:
  - (a) capable of being opened from both sides;
  - (b) readily identifiable and either:
    - (i) have the text “MUST BE CLOSED AT SEA” and “ESCAPE - DO NOT OBSTRUCT” in a contrasting colour that is highly visible; or
    - (ii) have IMO signage complying with IMO Resolution A.1116(30) and ISO 24409, with a minimum size of 10 cm x 30 cm. The applicable signage signs are “ESCAPE HATCH”, “EMERGENCY EXIT KEEP CLEAR” and “THIS HATCH MUST BE KEPT CLOSED AT SEA”;
  - (c) easy and safe to use, having due regard to their position; and
  - (d) when located within the forward quarter of a vessel’s length, must be forward hinged.

*Note* NSCV Section C1 contains requirements for marking of escape components.

## 6.8 Machinery space openings

Machinery space openings must be framed and enclosed by casings of a strength equivalent to the adjacent superstructure. External access openings in the machinery space must be fitted with doors complying with the requirements of clause 6.6.

## 6.9 Ventilators

- (1) The height above deck of ventilator coamings, other than machinery spaces ventilator coamings, must comply with Tables 9 to 12.
- (2) Machinery space ventilator coamings must be of a height at least 760 mm above deck in position 1 and 450 mm above deck in position 2. Coamings must not be the first point of downflooding and downflooding must not occur at an angle of heel of less than 40 degrees.

*Note* Ventilator openings should be located near the centreline and/or as high above the waterline as practicable so as not to prematurely compromise the vessel's stability. Ventilator openings must also comply with NSCV Subsection C5A.

- (3) Ventilator coamings must be of equivalent strength to the adjacent structure and capable of being closed weathertight by closing appliances permanently attached to the ventilator or adjacent structure. Where the coaming of any ventilator exceeds 900 mm in height above deck, it must be specially supported.

- (4) Closing appliances in vessels of 45 m or more in measured length need not be fitted to ventilators the coaming of which extend to more than 4.5 m above the working deck or more than 2.3 m above the superstructure deck. In vessels less than 45 m in measured length, closing appliances need not be fitted to ventilators the coaming of which extend to more than 3.4 m above the working deck or more than 1.7 m above the superstructure deck.

### 6.10 Air pipes and sounding devices

- (1) Where air pipes to tanks and void spaces below deck extend above the working or the superstructure deck, the exposed parts of the pipes must be of strength equivalent to the adjacent structures and fitted with appropriate protection.
- (2) Openings of air and sounding pipes must be provided with means of closing, permanently attached to the pipe or adjacent structure.
- (3) Air pipes must comply with the height above deck requirements of Tables 9 to 12.

### 6.11 Portlights, windows and skylights

- (1) The design and construction of portlights, windows and skylights on the vessel, and their frames or fixing arrangements, must comply with one of the following standards that is applicable to the type and operations of the vessel:
  - (a) ISO 1751 *Shipbuilding and marine structures — Ships' side scuttles*;
  - (b) ISO 3903 *Shipbuilding and marine structures — Ships' ordinary rectangular windows*;
  - (c) ISO 5797 *Ships and marine technology — Windows and side scuttles for fire-resistant constructions*;
  - (d) ISO 614: 2012 *Ships and marine technology — Toughened safety glass panes for rectangular windows and side scuttles — Punch method of non-destructive strength testing*;
  - (e) ISO 6345 *Shipbuilding and marine structures — Windows and side scuttles — Vocabulary*;
  - (f) ISO 21005 *Shipbuilding and marine technology — Thermally toughened safety-glass panes for windows and side scuttles*; or
  - (g) the rules of a Recognised Organisation covering side scuttles, windows and skylights.

*Note* International standards may be based on operational areas or operational conditions which differ to those contained in NSCV Part B. In these cases, the standard must be applied so that it is at least equivalent to the design environmental parameters in NSCV Part B.

- (2) The portlights, windows, and skylights must be assessed, installed, and tested in accordance with Chapter 7.
- (3) Portlights, windows and skylights at risk from damage by fishing gear must be suitably protected.
- (4) Portlights to spaces below the working deck, and to spaces within the enclosed structures on that deck, must be of the fixed type and fitted with hinged deadlights or portable storm covers capable of being closed watertight.
- (5) However, despite subsection (4), for vessels operating in operational area categories C, D or E, opening portlights are permitted to spaces below the working deck, and to spaces within the enclosed structures on that deck, where the vessel meets the requirements for one compartment subdivision in NSCV Section C6 and provided the opening portlights are:

- (a) located as high as practicable to the freeboard deck and at least 1,000 mm above the deepest loaded waterline;
  - (b) not located in the forward quarter of the hull;
  - (c) not located in a high fire risk space;
  - (d) marked “do not open at sea”; and
  - (e) for vessels in operational area category C – fitted with hinged deadlights.
- (6) No portlight may be fitted in a position such that its sill is less than 500 mm above the deepest loaded waterline.
- (7) Toughened safety glass or its equivalent must be used for wheelhouse windows.
- (8) Glazing in skylights must be thermally toughened safety glass and must be in accordance with an appropriate national or international marine standard, or the rules of a Recognised Organisation, that is applicable to the location of the skylight.
- (9) In addition, a skylight which is provided as a means of escape must comply with the requirements stated in clause 6.7(3)(a) to (d).
- (10) The design pressures used within calculations must not be less than those used in the vessel hull construction. The minimum window thickness must not be less than 6 mm in position 1 and 5 mm in position 2.

*Note 1* NSCV Section C1 contains additional requirements for wheelhouse windows.

*Note 2* NSCV Section C4 contains additional requirements for windows and portlights that form fire-resisting divisions.

## RAPID DRAINAGE OF WATER ON DECKS

### 6.12 Freeing ports

- (1) Where bulwarks in position 1 form wells, the minimum freeing port area on each side of the vessel for each well on the working deck, determined in accordance with the following equation, must be provided:

$$A = 0.07 \times 0.7LM$$

Where: A = minimum freeing port area on each side of the vessel in square metres

LM = measured length of the well in metres

h = height of bulwark in metres

- (2) In addition, for subsection (1):
- (a) where the bulwark is more than 1,200 mm in average height, the required minimum area is increased by 0.004 m<sup>2</sup> per metre of length of well for each 100 mm the bulwark is above 1,200 mm in average height; and
  - (b) where the bulwark is less than 900 mm in average height, the required minimum area is decreased by 0.004 m<sup>2</sup> per metre of length of well for each 100 mm the bulwark is below 900 mm in average height.
- (3) Where bulwarks within position 2 form wells, half the minimum freeing port area determined in accordance with subsection (1) must be provided.
- (4) Freeing ports must be arranged along the length of bulwarks to ensure water is rapidly and effectively drained from the deck. Lower edges of freeing ports must be as near

to the deck as practicable.

- (5) Poundboards and means for stowage of the fishing gear must be arranged so that the effectiveness of freeing ports will not be impaired. Poundboards must be constructed so that they can be locked in position when in use, and must not hamper the discharge of shipped water.
- (6) Freeing ports more than 300 mm in depth must be fitted with bars spaced between 150 mm and 230 mm apart, or must be provided with other suitable protective arrangements. Freeing port covers, if fitted, must comply with subsection (7).
- (7) If flaps are fitted to freeing ports, they must open outward, without resistance, from the bulwark to a position no less than 90° to the vertical plane of the bulwark. When a non-return shutter or flap is fitted to a freeing port it must have sufficient clearance to prevent jamming and any hinges must have pins or bearings of materials resistant to corrosion.
- (8) Where cargo is to be stowed on deck, the stowage arrangements must not impede the free flow of water from the deck.

*Note* Freeing ports are openings in the bulwarks on the open deck, designed to drain large quantities of water directly and rapidly overboard.

### 6.13 Scuppers and discharges

*Note 1* Scuppers are a system of gravity deck drains and connected piping leading from scupper wells to the side shell of the vessel. The purpose of a scupper is to drain small quantities of water from rain, spray etc.

*Note 2* NSCV Subsection C5A contains requirements for bilge alarms, inlets, discharges and valves, including discharge and inlet piping material, characteristics and thickness.

- (1) Scuppers must provide effective drainage to decks and enclosed spaces. They must be located where they will remain effective in any attitude of vessel trim between zero and 5 degrees, and any attitude of vessel heel between zero and 15 degrees. The combined cross-sectional area of all scuppers must be at least 700 mm<sup>2</sup> per square metre of cockpit deck area.
- (2) Scuppers on weather portions of decks, and scuppers leading from superstructures or deckhouses not provided with weathertight closing appliances, must be led overboard. Scuppers from spaces below the freeboard deck or spaces within closed superstructures, may be led to bilges.
- (3) An opening below the weather deck must be provided with a positive means of closure. The number of inlets and discharges must be kept to an operational minimum, except in relation to small discharges or machinery exhaust systems complying with the requirements of NSCV Subsection C5A.
- (4) Skin fittings must be of steel, bronze or other approved ductile material.
- (5) Where wet fish processing takes place within a weathertight space not having sufficient freeboard to permit direct overboard discharge via scuppers or other arrangements, the space must be provided with independent pumping arrangements having a capacity of at least 1.5 times the rate of water supply. Where pumping arrangements are intended to cater for solid waste, discharge should be arranged via local sumps with pumps suitable for pumping fish waste products.
- (6) Offal or gut chutes must be fitted with a screw down non-return flap of non-corrosive material which will remain closed at 15° of adverse heel, and have an opening at the hull aperture with no a single dimension greater than 300 mm x 300 mm (or 0.09 m<sup>2</sup>).
- (7) The access opening to the chute is to be at a minimum height of 900 mm above the deepest operational waterline, and must be fitted with a hinged weathertight cover

secured with clips or toggles in addition to the flap required by subsection (6).

- (8) Inlet and discharge pipes from marine toilets should be provided with shell fittings similar to that as required by clause 4.11 appropriate for the size of the vessel. When the rim of a marine toilet is less than 300 mm above the deepest loaded waterline of the vessel, anti-syphon measures must be installed unless otherwise indicated by manufacturer's recommendations.

## RESERVE BUOYANCY AND PREVENTION OF OVERLOADING

### 6.14 Maximum displacement

The maximum displacement for a vessel is the lesser of any of the following:

- (a) that determined in accordance with the applicable criteria of NSCV Section C6;
- (b) 200 mm freeboard; or
- (c) the maximum displacement assumed for the purpose of determining hull scantlings in NSCV Section C3.

### 6.15 Freeboard mark

A freeboard mark must:

- (a) be marked clearly on each side of the vessel in accordance with the requirements of Annex A; and
- (b) show the freeboard assigned in accordance with the maximum displacement determined at clause 6.14.

*Note* The freeboard mark is important to prevent overloading and to maintain adequate reserve buoyancy of the vessel. Overloaded vessels are at a greater risk of capsizing and sinking. The freeboard mark provides a visual reference point as to the loading condition of the vessel for anyone intending to board the vessel.

### 6.16 Portable fish-hold divisions

The catch must be properly secured against shifting which could cause dangerous trim or heel of the vessel.

### 6.17 Flooding of fish-holds

The angle of heel at which progressive flooding of fish-holds could occur through hatches which remain open during fishing operations, and which cannot rapidly be closed, must be at least 20° unless the stability criteria of NSCV Section C6 can be satisfied with the respective fish-holds partially or completely flooded.

### 6.18 Weathertight and watertight closing components

- (1) Tables 9 to 12 contain the minimum allowable heights of openings, coamings and sills.
- (2) Where a hatch is, under the applicable table, permitted to be flush:
  - (a) there must be a watertight seal;
  - (b) the opening should be dogged or secured at all edges;
  - (c) spaces accessible through the hatchway must be serviced by a bilge pump and bilge alarm;
  - (d) the hatch must not be necessary for general operations (where access is required to the space at sea);
  - (e) if the hatch provides the single means of access to an unmanned machinery space, then the vessel must have a second separated machinery space;

- (f) the hatch must not be of a width greater than half the beam of the vessel;
  - (g) if access is required through the hatch for activation of firefighting or bilge systems, then a remote means of activation from outside the space must be provided; and
  - (h) the hatch must be marked on both sides of the hatch cover with the following text: "MUST BE CLOSED AT SEA".
- (3) Watertight and weathertight components that serve multiple functions must comply with the most onerous requirements.

### **6.19 Marking of doors, mechanisms and valves**

- (1) Watertight and weathertight components normally closed at sea must be marked in accordance with this clause 6.19.
- (2) Suitable notices and signs must be provided on, or close to all doors, valves and closing appliances indicating their purpose, the procedures for operating them and any precautions to be observed.
- (3) The notices and signs must comply with one of the following standards for markings and graphical symbols, as applicable to the type of door, valve or closing appliance:
  - (a) ISO 7010:2019 *Graphical symbols - Safety colours and safety signs- Registered safety signs*;
  - (b) ISO 24409-2 *Ships and marine technology - Design, location and use of shipboard safety signs, fire control plan signs, safety notices and safety markings*;
  - (c) IMO *Safety and operating instruction for trained personnel (SIS)*, IMO Resolution A 952 (23) and IMO Resolution A 654 (16); or
  - (d) IMO *Mandatory Action Signs*.

*Note 1* See clause 3.6 for an example of an IMO Mandatory Action Sign.

*Note 2* NSCV Subsection C6B contains requirements and standards for door performance criteria, additional markings and indications of various type of watertight doors.



**Table 9 Watertight and weathertight components for Class 3 vessels  $\geq 24$  m to  $<45$  m in length in offshore waters**

Watertight and weathertight components	Minimum height requirements for Class 3 vessels 24 m or more but less than 45 m in length in A, B Extended, B and C operational areas			
	Position 1	Position 2	No direct access leading below the weather deck	Normally closed at sea (regardless of position)
Shell openings (non-opening portlights, windows and other miscellaneous small openings)	500 mm above the deepest loaded waterline			
Escape hatches coaming heights	<p>Must be located a minimum height of 1,200 mm above the deepest loaded waterline or have a minimum coaming height of 450 mm and in both cases must meet the requirements of clause 6.7(3). Adequate protection must be provided for escape purpose in all foreseeable environmental conditions if using a flush hatch, see 6.7.</p> <p><i>Example</i> Any escape hatch will need to consider the installation location and the risk of boarding seas in all environmental conditions of operation, large amounts of green water will impede escape and place the vessel at flooding risk. Other deck hardware and fittings also need to be considered to allow for a person to safety and swiftly escape unimpeded.</p>			
Machinery access hatch coaming heights	600 mm	300 mm	Flush	Flush
Other hatches	600 mm	Flush	Flush	Flush
Door and access sill heights to enclosed spaces	600 mm	300 mm	minimum to provide seal <sup>1</sup>	minimum to provide seal
Ventilators heights	760 mm	450 mm	450 mm	--
Air Pipe heights	760 mm	450 mm	450 mm	--

<sup>1</sup> Minimum to provide a seal that is weathertight.

**Table 10 Watertight and weathertight components for Class 3 vessels  $\geq 24$  m to  $<45$  m in length in sheltered waters**

Watertight and weathertight components	Requirements for Class 3 vessels 24 m or more but less than 45 m in length in D and E operational areas			
	Position 1	Position 2	No direct access leading below the weather deck	Normally closed at sea (regardless of position)
Shell openings (non-opening portlights, windows and other miscellaneous small openings)	300 mm above the deepest loaded waterline			
Escape hatches coaming heights	<p>Must be located a minimum height of 1,000 mm above the deepest loaded waterline or have a minimum coaming height of 300 mm and in both cases must meet the requirements of clause 6.7(3). Adequate protection must be provided for escape purpose in all foreseeable environmental conditions if using a flush hatch, see 6.7.</p> <p><i>Example</i> Any escape hatch will need to consider the installation location and the risk of boarding seas in all environmental conditions of operation, large amounts of green water will impede escape and place the vessel at flooding risk. Other deck hardware and fittings also need to be considered to allow for a person to safety and swiftly escape unimpeded.</p>			
Machinery access hatch coaming heights	300 mm	150 mm	Flush	Flush
Other hatches	300 mm	Flush	Flush	Flush
Door and access sill heights to enclosed spaces	300 mm	150 mm	minimum to provide seal <sup>1</sup>	minimum to provide seal
Ventilators heights	600 mm	375 mm	375 mm	--
Air Pipe heights	760 mm	450 mm	450 mm	--

<sup>1</sup> Minimum to provide a seal that is weathertight.

**Table 11 Watertight and weathertight components for Class 3 vessels greater than 45 m in length in offshore waters**

Watertight and weathertight components	Requirements for Class 3 vessels greater than 45 m in length in A, B Extended, B and C operational areas			
	Position 1	Position 2	No direct access leading below the weather deck	Normally closed at sea (regardless of position)
Shell openings (non-opening portlights, windows and other miscellaneous small openings)	500 mm above the deepest loaded waterline			
Escape hatches coaming heights	<p>Must be located a minimum height of 1,500 mm above the deepest loaded waterline or have a minimum coaming height of 450 mm and in both cases must meet the requirements of clause 6.7(3). Adequate protection must be provided for escape purpose in all foreseeable environmental conditions if using a flush hatch, see 6.7.</p> <p><i>Example</i> any escape hatch will need to consider the installation location and the risk of boarding seas in all environmental conditions of operation, large amounts of green water will impede escape and place the vessel at flooding risk. Other deck hardware and fittings also need to be considered to allow for a person to safety and swiftly escape unimpeded.</p>			
Machinery access hatch coaming heights	600 mm	300 mm	Flush	Flush
Other hatches	300 mm	Flush	Flush	Flush
Door and access sill heights to enclosed spaces	600 mm	300 mm	minimum to provide seal <sup>1</sup>	minimum to provide seal
Ventilators	900 mm	760 mm	760 mm	--
Air Pipes	760 mm	450 mm	450 mm	--

<sup>1</sup> Minimum to provide a seal that is weathertight.

**Table 12 Watertight and weathertight components for Class 3 vessels greater than 45 m in length in sheltered waters**

Watertight and weathertight components	Requirements for Class 3 vessels greater than 45 m in length in D and E operational areas			
	Position 1	Position 2	No direct access leading below the weather deck	Normally closed at sea (regardless of position)
Shell openings (non-opening portlights, windows and other miscellaneous small openings)	300 mm above the deepest loaded waterline			
Escape hatches coaming heights	<p>Must be located a minimum height of 1,200 mm above the deepest loaded waterline or have a minimum coaming height of 300 mm and in both cases must meet the requirements of clause 6.7(3). Adequate protection must be provided for escape purpose in all foreseeable environmental conditions if using a flush hatch, see 6.7.</p> <p><i>Example</i> any escape hatch will need to consider the installation location and the risk of boarding seas in all environmental conditions of operation, large amounts of green water will impede escape and place the vessel at flooding risk. Other deck hardware and fittings also needs to be considered to allow for a person to safety and swiftly escape unimpeded.</p>			
Machinery access hatch coaming heights	300 mm	150 mm	Flush	Flush
Other hatches	300 mm	Flush	Flush	Flush
Door and access sill heights to enclosed spaces	300 mm	150 mm	minimum to provide seal <sup>1</sup>	minimum to provide seal
Ventilators heights	600 mm	375 mm	375 mm	--
Air Pipe heights	760 mm	450 mm	450 mm	--

<sup>1</sup> Minimum to provide a seal that is weathertight.

## Chapter 7 Assessment, installation and testing of watertight and weathertight closing appliances and equipment

### 7.1 Application

This Chapter contains the requirements for the installation and verification of components, manufactured items and systems that ensure watertight and weathertight integrity.

*Note* The design and construction standard to which the component, manufactured item or system of watertight and weathertight integrity is constructed may include requirements for assessment, installation and/or testing. Where those requirements are complied with, the requirements of this Chapter 7 will be satisfied, provided that any gaps in the assessment, installation and testing requirements of the standard are met through compliance with the other options contained in this Chapter 7.

### 7.2 Competence

A competent person or organisation must undertake the final installation testing of components, manufactured items and systems that ensure watertight and weathertight integrity. Competence must be relevant to the equipment. Competent persons or organisations must be:

- (a) accredited or licensed by an appropriate National or State authority or administration; or
- (b) accredited or licensed by a Recognised Organisation; or
- (c) the manufacturer of the closing device, an agent of the manufacturer or an agent approved by the manufacturer.

### 7.3 Assessment

- (1) Each component, manufactured item or system that ensures watertight and weathertight integrity must be assessed and verified as meeting the applicable standard, specification or test mentioned in this Section.
- (2) To be deemed to satisfy this requirement, the component, manufactured item or system that ensures watertight and weathertight integrity must:
  - (a) be tested for the purpose specified in this Section by an organisation recognised by the National Association of Testing Authorities (NATA) or by a specialised laboratory such as the Scientific Service Laboratory (SSL);
  - (b) be of a type approved by a Recognised Organisation;
  - (c) have a document, signed by the closing appliance manufacturer, stating that the item conforms with the applicable standards and specifications and that that tests confirming compliance have been carried out on samples from production; or
  - (d) be assessed against a standard or deemed to satisfy solution, by a competent person, including consideration and assessment of manufacturing data, specifications, and mechanical properties.

### 7.4 Installation and testing

- (1) Watertight and weathertight closing appliances and equipment components must be installed and have their tightness verified, as applicable, by a competent person in accordance with:
  - (a) the specifications for installation and testing that form part of the applicable standard; or

- (b) where the standard does not contain specifications for installation or testing, either:
- (i) the specification and instructions from an original equipment manufacturer pertaining to installation and testing; or
  - (ii) Table 13.

*Note 1* Table 13 does not replace specific testing requirements contained in international standards or the rules of a Recognised Organisation. The requirements of Table 13 apply when testing requirements are not specified. The requirements of Table 13 are most suited to vessels <35 m in length.

*Note 2* A standard may contain only some requirements for testing, in which case any gaps in requirements would need to be covered by compliance with Table 13. For example, a manufacturer or testing authority may provide evidence that a vessel window manufactured to ISO 12216 2002-06 (E) meets the standard. Installation verification would then be conducted by a competent person in accordance with Table 13.

- (2) Watertight and weathertight closing devices and equipment components must be tested to ensure their tightness is consistent with their functions and importance to vessel safety.

**Table 13 Closing and component installation testing requirements**

Closing device/component	Testing requirement	Testing duration and other requirements
Windows, portlights and skylights	Hose test <sup>1</sup> for: Category A & B vessels – 100% of devices/components Category C vessels – 50% devices/components Category D & E vessels – 25% devices/components  If any water penetrates then 100% testing is required and rework until no water penetrates.	An all-round sweeping pass of the required sample size. The water jet is to impinge directly upon joints and or fixing.
Watertight doors	Hose test <sup>1</sup> 100% of doors. If any water penetrates than rework door to seal alignment as required until the door can pass the Hose test <sup>1</sup> .	100% pass around all joints between seal and door.
Weathertight doors	Category A & B vessels – 50% Hose test <sup>1</sup> with the remaining 50% to have Chalk test <sup>2</sup> . Category C, D & E – 100% of doors to have Chalk test <sup>2</sup> . If any fail rework as required and Hose test <sup>1</sup> until acceptable.	100% pass around all joints between seal and door.
Hatches (Flush and with coaming)	Position 1: Hose test <sup>1</sup> Position 2: Chalk test <sup>2</sup>	

Closing device/component	Testing requirement	Testing duration and other requirements
Skin fittings (watertight penetrations of the hull)	<p>Either Hose test<sup>1</sup> or NDT<sup>4</sup> a sample not less than 50% and at least one of each different type to give assurance that the production methodology provides watertight integrity.</p> <p><i>Note</i> Class A, B Extended, B and C vessels are recommended to have a 100% sample tested unless vessels are sister ships with the same production methodologies.</p>	Hose test <sup>1</sup> 100% pass around all joints between seal and door. Dwell time for dye penetrate is a minimum of 15 minutes.
Other penetrations (hull internal penetration and weathertight structure) penetrations)	Light test <sup>3</sup> : 100% of accessible internal hull watertight penetrations, and 50% of other weathertight penetrations	

- 1 Hose test – Hose test, a pressure of 200kPa must be maintained. The nozzle is to have a minimum inside diameter of 12 mm and be at a perpendicular distance from the joint not exceeding 1.5 m.
- 2 Chalk test – Chalk test, apply a contrasting colour chalk to the entire seal and close the closing appliance and check for witness marks around the entire interface. Any areas without witness chalk should be repeated and adjustments made to the closing device until the entire sealing interface is proven to be in contact with the seal.
- 3 Light test – Using a light source of at least 500 lumens, with the vessel in a darkened state, hold light source on one side and verify on the other side the absence of light as light is passed around the penetration. You may need two people and a means to communicate on large vessels with bulkheads.
- 4 NDT (Non-destructive testing) – Dye penetrate using the capillary action is very efficient at leak detection on aluminium and steel vessels. Other types of NDT can also be used to provide assurance that the weld and weld to closing device will not be a source of leak and compromise watertight integrity of the vessel

## Annex A Freeboard and Load Line Mark

### A1 Scope of Annex

This annex provides the detail of the freeboard and load line mark requirements.

*Note* NSCV Subsection C6B contains subdivision load line requirements for vessels of flooding risk III and IV.

### A2 Objective

- (1) To provide a permanently visible mark on each side of the vessel, through a freeboard mark (for non-load line vessels) or a load line mark (for load line vessels), to assist to determine if the loading of the vessel is compliant.
- (2) Overloaded vessels are at a greater risk of capsizing and sinking. Freeboard and load line marks help to prevent overloading, and to ensure adequate reserve buoyancy of the vessel is maintained, by providing a visual reference point as to the loading condition of the vessel.
- (3) Where a vessel is loaded at any time so that, if the vessel were floating without a list in still salt water of a specific gravity of 1.025, the appropriate load line or freeboard marked on either side of the vessel would be submerged, the vessel is deemed to be overloaded.

**Figure 5 Freeboard mark position, with a compliant loading condition**

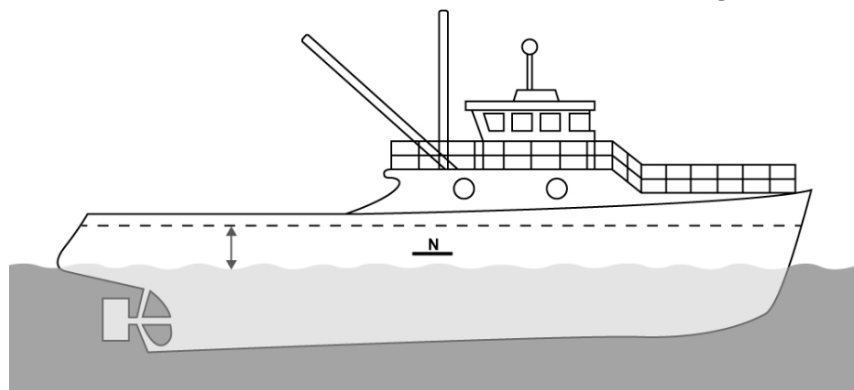

**Figure 6 Non-compliant loading condition with the freeboard mark submerged**

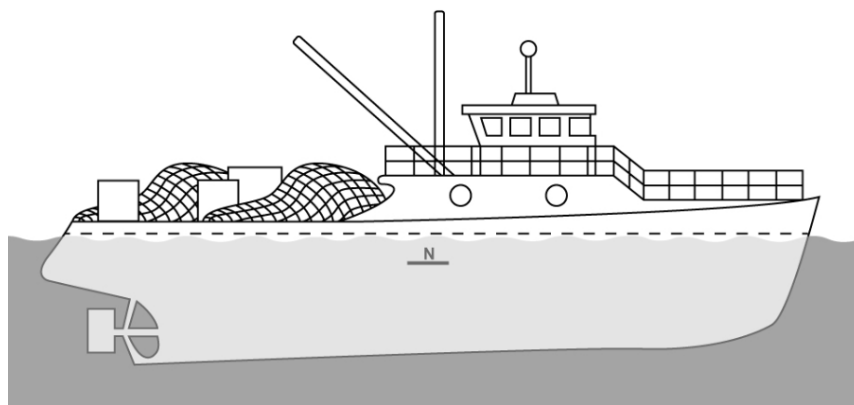



**A3 Specifications of the deck line and freeboard mark**

- (1) Deck lines on all vessels must comply with Figure 7.
- (2) The freeboard mark must be:
  - (a) in a contrasting colour to the hull;
  - (b) compliant with the dimensions and other specifications of Figures 8 or 9, as applicable to the vessel;
  - (c) on each side of the vessel at the Longitudinal Centre of Flotation (LCF) of the deepest waterline as shown in Figure 5; and
  - (d) assigned in accordance with the maximum displacement determined at clauses 4.19, 5.3 and 6.14.

*Note* For subdivision load line requirements for vessels of flooding risk III and IV – see NSCV Subsection C6B.

**Figure 7 Deck line for all vessels**

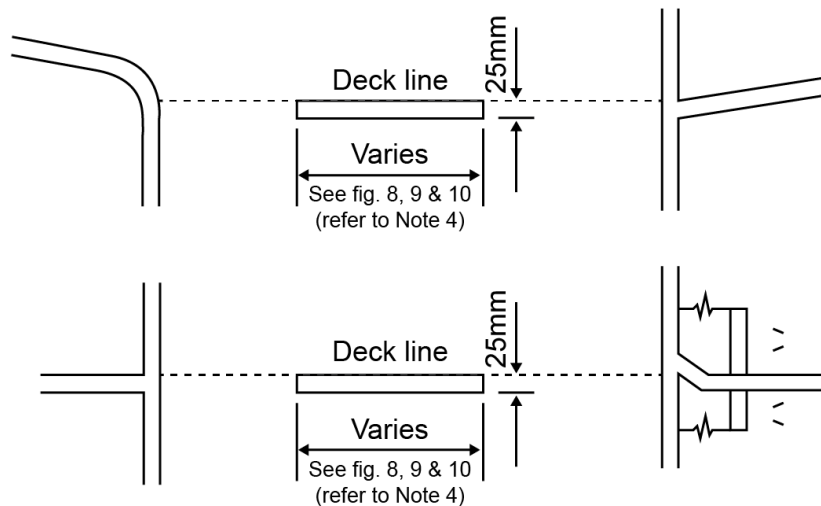

*Notes to Figure 7*

1. Permanent marking on steel or aluminium vessels is normally by welding of pre-cut components, cutting-in or centre punching.
2. Permanent marking on wooden vessels is normally by cutting-in to a depth of 2 mm or more into the planking.
3. Permanent marking on FRP vessels can be achieved by permanently gluing with structural adhesive pre-glassed coremat or 2 mm thick FRP markings.
4. Deck line dimension varies depending on the vessel length.

**Figure 8 Freeboard mark for vessels <24 m in length**

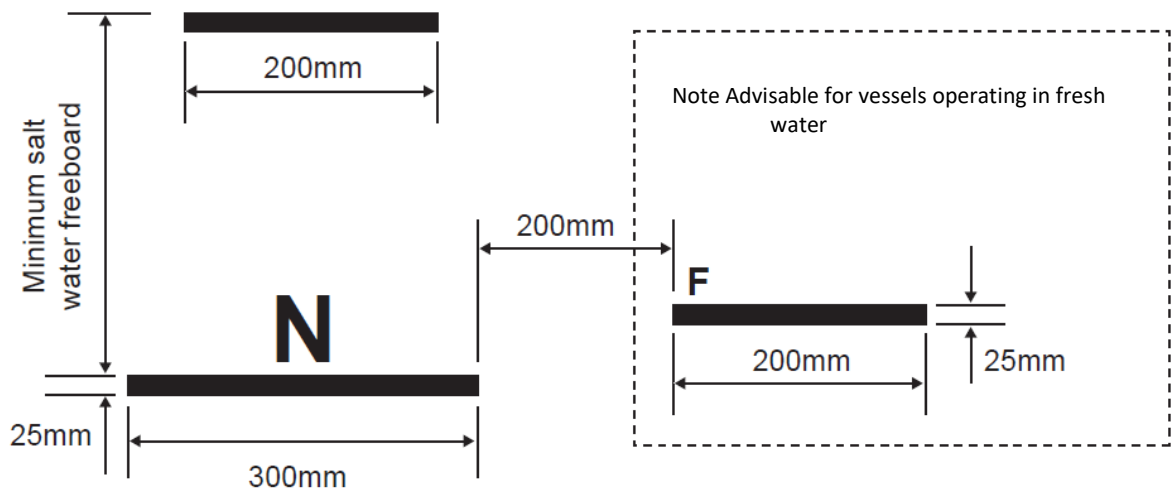

*Notes to Figure 8*

1. Permanent marking on steel or aluminium vessels is normally by welding of pre-cut components, cutting-in or centre punching.
2. Permanent marking on wooden vessels is normally by cutting-in to a depth of 2 mm or more into the planking.
3. Permanent marking on FRP vessels can be achieved by permanently gluing with structural adhesive pre-glassed coremat or 2 mm thick FRP markings.
4. The letter N represents the National Regulator and must be at least 100 mm in height.

**Figure 9 Freeboard mark for vessels ≥24 m in length**

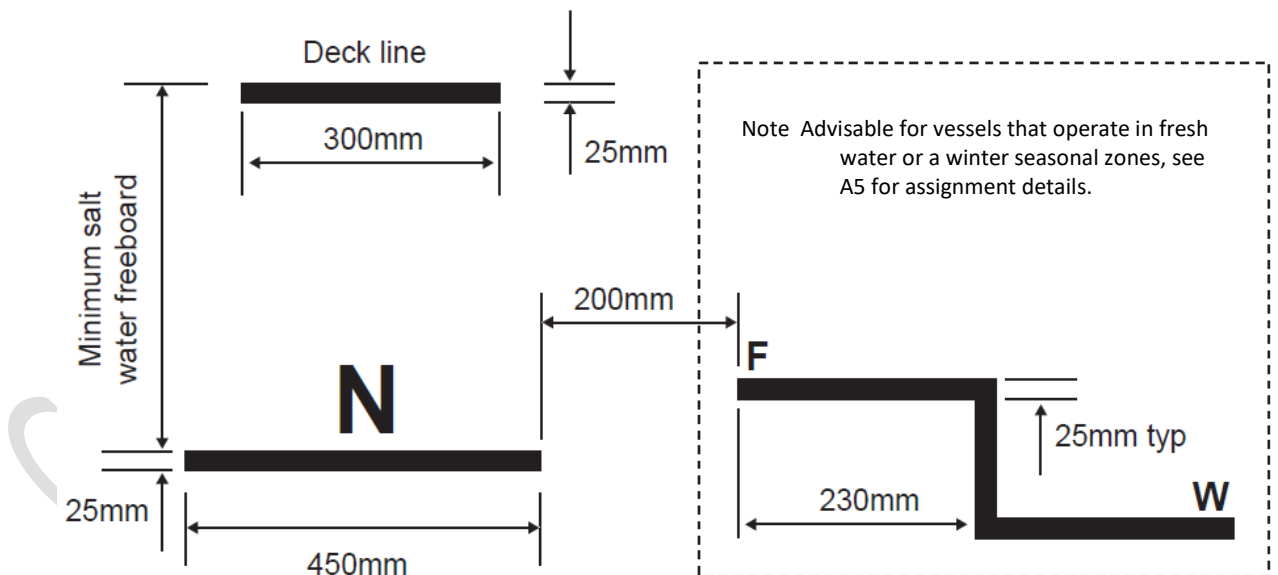

*Notes to Figure 9*

1. Permanent marking on steel or aluminium vessels is normally by welding of pre-cut components, cutting-in or centre punching.
2. Permanent marking on wooden vessels is normally by cutting-in to a depth of 2 mm or more into the planking.
3. Permanent marking on FRP vessels can be achieved by permanently gluing with structural adhesive pre-glassed coremat or 2 mm thick FRP markings.
4. The letter N represents the National Regulator and must be at least 100 mm in height.

**A4 Dimensions of the load line mark**

For vessels that require a load line mark, the load line mark must comply Figure 10.

**Figure 10 - Deck line and Load Line Mark**

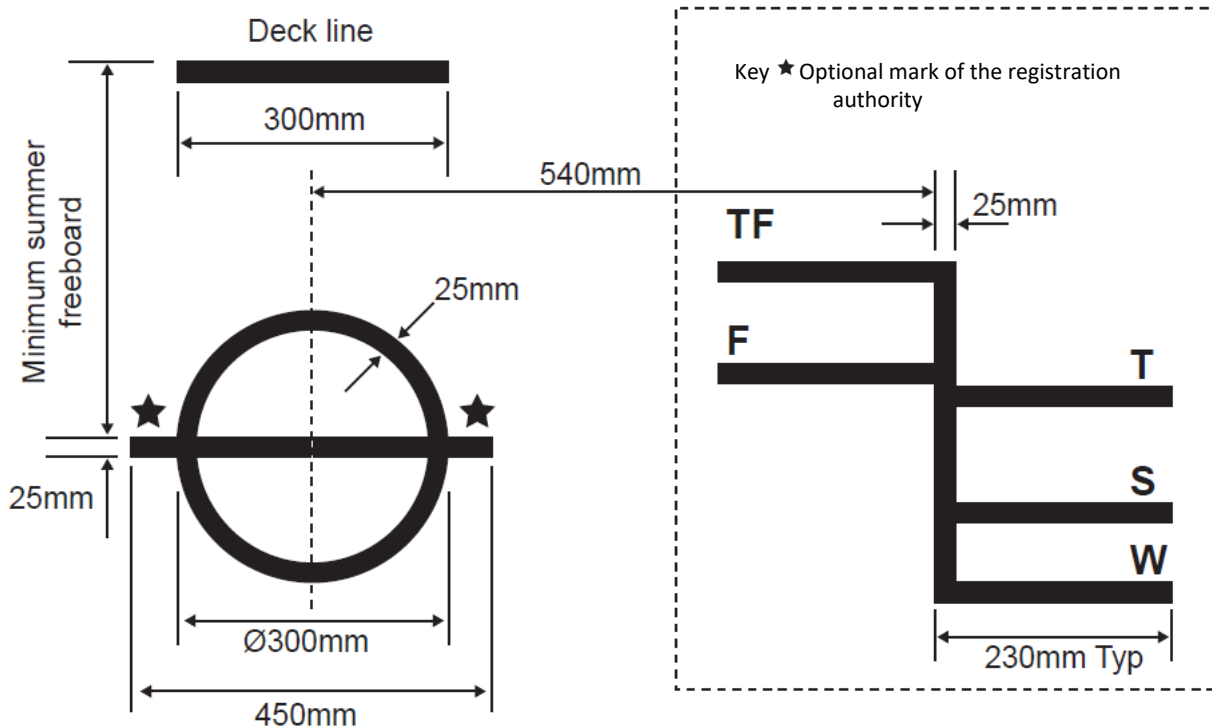
**A5 Determining the appropriate load lines within the Australian Exclusive Economic Zone (AEEZ) and adjacent Islands**

This section contains those Zones, Seasonal Zones and Areas, the respective Seasonal Periods of such Zones, for the determination of appropriate Load Lines to which vessels are permitted to load.

The following Zones and Areas are contained within the following limits:

- Latitude 00° 00' to Latitude 55° 00' S
- Longitude 98° 00' E to Longitude 170° 00' E

**Tropical Zone Area 1 (Northern Australia)**

This area will be within those waters that lie to the southward of the Equator and to the northward of a Rhumb line drawn from a position latitude 10° 00' S longitude 98° 00' E to Port Darwin, thence along the north coast of Australia and the coast of Wessel Island eastwards to Cape Wessel, then along the parallel of latitude 11° 00' S to the west side of Cape York and from the East side of Cape York along the parallel of latitude 11° 00' S to longitude 170° 00' E.

**Tropical Zone Area 2 (Great Barrier Reef)**

This area will be bounded in the south by the parallel of latitude 22° 00' S, from the east coast of Australia to the Great Barrier Reef, then northwards along the Great Barrier Reef to latitude 11° 00' S and thence along that parallel to the east side of Cape York, Australia.

### **Seasonal Tropical Zone**

The Seasonal Tropical Zone will be divided into three areas:

#### *Area 1 - South Indian Ocean Seasonal Tropical Area:*

This area will be bounded in the south from longitude 98° 00' E along the parallel of latitude 15° 00' S to longitude 114° 00' E and thence southward along the meridian of longitude of 114° 00' to the coast of North-west Australia, thence north-eastward along the coast of Australia to Port Darwin and thence along a rhumb line drawn from Port Darwin to position latitude 10° 00' S longitude 98° 00' E.

The Seasonal Tropical period for this area will commence on the first day of May in a year and end on the thirtieth day of November in that year.

The Seasonal Summer period for this area will commence on the first day of December in one year and end on the thirtieth day of April in the following year.

#### *Area 2 - South Pacific Ocean Seasonal Tropical Area (Gulf of Carpentaria):*

This area will be within that part of the Gulf of Carpentaria that lies south of latitude 11° 00' S.

The Seasonal Tropical period for this area will commence on the first day of April in a year and end on the thirtieth day of November the same year.

The Seasonal Summer period for this area will commence on the first day of December in one year and end on the thirty-first day of March the following year.

#### *Area 3 - South Pacific Ocean Seasonal Tropical Area (East of Great Barrier Reef):*

This area Must be bounded in the north and east by the southern boundary of the Tropical Zone (11° 00'S), to longitude 170° 00' E, thence in the south along the Tropic of Capricorn (23° 30' S) to longitude 154° 00'E, then southward to 24° 00'S, thence westward to the east coast of Australia, thence northward along the east coast of Australia, to latitude 22° 00' S, thence eastwards to the Great Barrier Reef and northwards along the Great Barrier Reef until it joins the Tropical Zone at 11° 00' S.

The Seasonal Tropical period for this area will commence on the first day of April in a year and end on the thirtieth day of November in that year.

The Seasonal Summer period for this area will commence on the first day of December in one year and end on thirty-first day of March in the following year end on thirty-first day of March in the following year.

### **Southern Winter Seasonal Zone**

This area Must lie to the southward of a line drawn from position latitude 35° 10' S, longitude 98° 00' E to a position at latitude 35° 30' S, longitude 118° 00' E, thence along a rhumb line to Cape Grim on the north-west coast of Tasmania, thence along the north and east coasts of Tasmania to the southernmost 49 point of Bruny Island, thence along a rhumb line to Black Rock Point on Stewart Island, New Zealand, thence along the rhumb line to the point latitude 47° 00'S, longitude 170° 00' E.

The Seasonal Southern Winter Period will commence on the sixteenth day of April in a year and end on the fifteenth day of October of that year.

The summer period of the Southern Winter Seasonal Zone will commence on the sixteenth day of October of a year and end on the fifteenth day of April the following year.

**Summer Zone**

The Summer Zone is the area that lies to the southward of the Seasonal Tropical Zones as defined, and to the northward of the Southern Winter Seasonal Zone as defined and between the longitudes 98° 00' E and 170° 00' E.

**Figure 11 Zones**

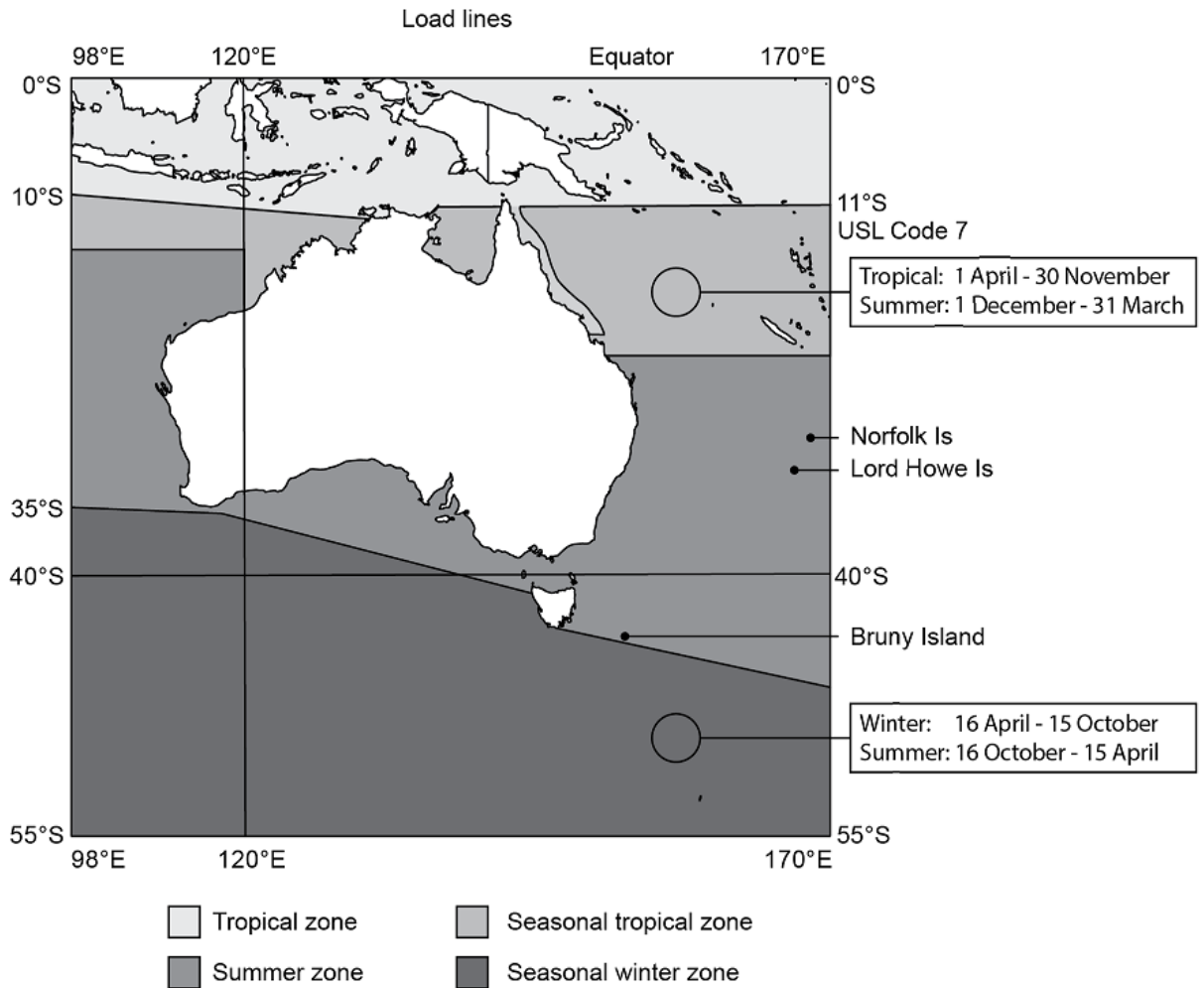

## Annex B Overview of ICLL requirements for domestic commercial vessels

### B1 Scope of Annex

This annex provides an overview of the ICLL requirements for domestic commercial vessels, including the specifications, modifications and additional requirements contained in Chapter 3.

*Note* For vessels subject to Chapter 5, the modifications and requirements contained in Chapter 5 also apply.

**Table 14 Overview of ICLL and NSCV C2 requirements for domestic commercial vessels**

ICLL Annex I Chapter & Regulation number	Regulation title	Requirements for domestic commercial vessels
1/1	Strength and intact stability of ships	Vessels built and maintained in accordance with the rules of a Recognised Organisation or the NSCV are deemed to comply with the requirements for structural strength and stability.
1/2	Application	As mentioned in Regulation 2 of the ICLL and clause 3.1 of NSCV Section C2.
1/2-1	Authorization of recognised organizations	Authorised organisations include an organisation or person authorised by the National Regulator to carry out load line surveys on domestic commercial vessels.
1/3	Definitions of terms used in the annexes	The definitions contained in the ICLL apply. Where a term used in the ICLL is not defined in the ICLL, the definitions at clause 1.4 of NSCV Section C2 apply.
1/4	Deck line	As set out in ICLL Regulation 4. See Annex A of this NSCV Section C2 for a summary of the deck line requirements of the ICLL.
1/5	Load line mark	As set out in ICLL Regulation 5. See Annex A of this NSCV Section C2 for a summary of the load line mark requirements of the ICLL.
1/6	Lines to be used with the Load line mark	As set out in ICLL Regulation 6. See Annex A (Figure 10) of this NSCV Section C2 for a summary of the load line mark requirements of the ICLL.
1/7	Mark of assigning authority	As set out in ICLL Regulation 7. See Annex A (Figure 10) of this NSCV Section C2 for a summary of the marking requirements of the ICLL. In Annex A, the mark of the registration authority is the mark of the assigning authority and could include a Recognised Organisation.

ICLL Annex I Chapter & Regulation number	Regulation title	Requirements for domestic commercial vessels
1/8	Details of marking	As set out in ICLL Regulation 8. See Annex A of this NSCV Section C2 for a summary of the marking requirements of the ICLL
1/9	Verification of marks	Authorised organisations include an organisation or person authorised by the National Regulator to carry out load line surveys on domestic commercial vessels. The authorised organisation or person must have verified the marks are correctly and permanently indicated on the ship's sides.
Conditions of assignment of freeboard II/10	Information to be supplied to the master	As set out in ICLL Regulation 10. The requirement to provide the master with loading information includes a requirement to provide a ship specific approved stability booklet with relevant damage stability calculations. The stability book must be in accordance with ICLL Regulation 10 and the NSCV subsections C6A, C6B, C6C, F1B, and F1C, as applicable to the vessel.
II/11	Superstructure end bulkheads	Bulkheads at exposed ends of enclosed superstructures which are built and maintained in accordance with the rules of a Recognised Organisation or the NSCV will be deemed to comply with ICLL Regulation 11.
II/12	Doors	As set out in ICLL Regulation 12 and clauses 3.3 and 3.6 of NSCV Section C2.
II/13	Position of hatchways, doorways and ventilators	As set out in ICLL Regulations II/13 to 22-2 and clause 3.7 of NSCV Section C2.
II/14	Cargo and other hatchways	
II/14-1	Hatchway coamings	
II/15	Hatchways closed by portable covers and secured weathertight by tarpaulins and battening devices	
II/16	Hatchways closed by weathertight covers of steel or	

ICLL Annex I Chapter & Regulation number	Regulation title	Requirements for domestic commercial vessels	
	other equivalent material fitted with gaskets and clamping devices	As set out in ICLL Regulations II/13 to 22-2 and clause 3.7 of NSCV Section C2.	
II/17	Machinery space openings		
II/18	Miscellaneous openings in freeboard and superstructure decks		
II/19	Ventilators		
II/20	Air pipes		
II/21	Cargo ports and other similar openings		
II/22	Scuppers, inlets and discharges		
II/22-1	Garbage chutes		
II/22-2	Spurling pipes and cable lockers		
II/23	Side scuttles, windows & skylights		As set out in ICLL Regulation 23 and clause 3. of NSCV Section C2.
II/24	Freeing ports		As set out in ICLL Regulation 24.
II/25	Protection of the crew	Either as set out in: - ICLL Regulation 25; or - clause 3.5 of NSCV Section C2.	
II/25-1	Means for safe passage of crew	Either as set out in: - ICLL Regulation 25-1; or - clause 3.5 of NSCV Section C2.	
II/26	Special conditions of assignment for type 'A' ships	As set out in ICLL Regulation 26.	
Freeboards III/27	Types of ships	As set out in ICLL Regulations 27 to 40.	
III/28	Freeboard tables		



ICLL Annex I Chapter & Regulation number	Regulation title	Requirements for domestic commercial vessels
III/29	Correction to the freeboard for ships under 100 m in length	As set out in ICLL Regulations 27 to 40.
III/30	Correction for block coefficient	
III/31	Correction for depth	
III/32	Correction for position of deck line	
III/32-1	Correction for recess in freeboard deck	
III/33	Standard height of superstructure	
III/34	Length of superstructure	
III/35	Effective length of superstructure	
III/36	Trunks	
III/37	Deduction for superstructure and trunks	
III/38	Sheer	
III/39	Minimum bow height and reserve buoyancy	
III/40	Minimum freeboards	
IV/41to 45	Special requirements for ships assigned timber freeboards	As set out in ICLL Regulations 41 to 45.
Annex II/46 to 52	Zones, areas and seasonal periods	As set out in ICLL Regulations 46 to 52. See Annex A of NSCV Section C2 for a summary of the zones, areas and seasonal periods relevant to domestic commercial vessels.

ICLL Annex I Chapter & Regulation number	Regulation title	Requirements for domestic commercial vessels
<b>Annex III – Certificates</b>	Form of International Certificate on Load Lines	The form of the load line certificate is to be as specified by the National Regulator. <i>Note</i> A certificate issued in accordance with Marine Order 507 accompanied by a Load line Conditions of Assignment Report and an Initial Load Line Survey Report may be required.

CONSULTATION DRAFT