National Standard for Commercial Vessels

PART C

DESIGN AND CONSTRUCTION

SECTION 6

STABILITY

Subsection 6C

STABILITY TESTS AND STABILITY INFORMATION

Edition 2.4

This edition 2.4 was prepared by the Australian Maritime Safety Authority to incorporate the NSCV Omnibus amendments instrument No.1, 2022.

NSCV Omnibus amendments instrument No. 1, 2022 was approved by the National Marine Safety Regulator on 6 September 2022 and endorsed by the Infrastructure and Transport Ministers on 11 November 2022.

This edition 2.4 commences on 1 January 2023.

Published by Australian Maritime Safety Authority, GPO Box 2181 Canberra, ACT 2601.

Copyright



© Australian Maritime Safety Authority 2022

The Australian Maritime Safety Authority encourages the dissemination and exchange of information provided in this publication.

Except as otherwise specified, all material presented in this publication is provided under Creative Commons Attribution 4.0 International licence. This excludes:

- the Commonwealth Coat of Arms
- this AMSA's logo
- content supplied by third parties.

The Creative Commons Attribution 4.0 International Licence is a standard form licence agreement that allows you to copy, distribute, transmit and adapt this publication provided that you attribute the work. The details of the version 4.0 of the licence are available on the Creative Commons website, as is the full legal code for that licence.

Attribution

The AMSA's preference is that you attribute this publication (and any material sourced from it) using the following wording:

Source: Australian Maritime Safety Authority,

Source:

© Australian Maritime Safety Authority, *National Standard for Commercial Vessels, Part C - Design and Construction, Section 6 – Stability, Subsection 6C - Stability Tests and Stability Information*

More information

For inquiries regarding copyright including requests to use material in a way that is beyond the scope of the terms of use that apply to it, please contact us.

Disclaimer

The Australian Maritime Safety Authority accepts no liability for the accuracy of the information nor its use or the reliance placed on it.

FOREWORD

This Subsection of the National Standard for Commercial Vessels (NSCV) was developed following a review of the Uniform Shipping Laws (USL) Code Section 8: Stability, Subsection 8A: Preliminary, Subsection B: Simplified Presentation of Stability and Sub-Section C: Stability Criteria. In reviewing the USL Code and preparing this Subsection, consideration was given to a number of factors, including:

- The National Marine Safety Strategy.
- Current vessel designs and construction practices.
- Relevant national and international standards.
- Provisions no longer used.
- Current survey practice, both formal and informal.
- Discretionary requirements which rely on Authority approval.
- Current technical standards format and style.

This Part of the National Standard for Commercial Vessels must be read in conjunction with Part A—Safety Obligations, Part B—General Requirements, Part C—Design and Construction Subsection 2A—Watertight and Weathertight Integrity—Load Line Vessels, Subsection 6A —Intact Stability Requirements and Subsection 6B—Buoyancy and Stability After Flooding.

This Subsection of the NSCV was prepared by the NMSC Secretariat in consultation with a working group comprising representatives from the various State and Territory marine authorities. In addition specialist advice was sought on a number of issues.

This draft Subsection was released for public comment as Subsection 6B on 10 October 2005, along with a draft Regulatory Impact Statement (RIS). A reference group comprising industry and government reviewed the public comment on Subsection 6B on 29 and 30 May 2006 and 20 and 21 March 2007. Due to the extent of changes arising from their deliberations, the reference group recommended that the revised draft be subject to a second round of public comment. The second draft was released for public comment on 2 April 2007. The reference group met on 3 and 4 July 2007, with recommendations forwarded to NMSC.

NMSC approved this Subsection as Subsection 6C on 14 August 2007, with the Office of Best Practice Regulation reporting that the final RIS was satisfactory on 28 September 2007. The Australian Transport Council (ATC) endorsed the document for publication on 29 February 2008.

The ATC later endorsed the inclusion of additional text covering buoyancy and stability after flooding information and criteria on 30 April 2010. In addition, Correction Amendment 1 to Clauses 5.3, 5.4.6.3, A7.14, A8.2, L6 and Tables A.16 and D.7 was approved by NMSC on 5 October 2010. The correction amendment, together with the additional text approved by ATC, were incorporated into a new edition of the standard published in October 2010.

CONTENTS

FOREWORD	3
CONTENTS	4
CHAPTER 1 PRELIMINARY	9
1.1 Scope	9
1.2 Application.....	9
1.3 Objectives of Subsection 6C	9
1.4 Referenced documents.....	9
1.5 Definitions and abbreviations	10
CHAPTER 2 REQUIRED OUTCOMES	13
2.1 Scope	13
Required outcomes	13
2.2 Operator to be provided with relevant information on stability.....	13
2.3 Accuracy	13
2.4 Relevance to hazards	13
2.5 Conditions of loading	13
2.6 Limits of operation	13
2.7 Completeness of content.....	14
2.8 Stability information to be suitable for use by the operator.....	14
2.9 Testing methodology	14
Deemed-to-satisfy solutions.....	14
2.10 Compliance	14
Equivalent solutions.....	14
2.11 Assessment methods	14
CHAPTER 3 METHODS FOR ESTABLISHING AND VERIFYING LIGHTSHIP PARTICULARS.....	15
3.1 Scope	15
3.2 Application.....	15
3.3 Determination of lightship particulars	15
3.4 Verification of lightship particulars	18
CHAPTER 4 METHODS FOR CONDUCTING SIMPLIFIED STABILITY TESTS	20
4.1 Scope	20
4.2 Application.....	20
4.3 Objective	20

4.4	Types of simplified stability tests	20
4.5	Stability compliance report	21
4.6	Sister vessels	21
CHAPTER 5	PRESENTATION OF STABILITY INFORMATION	22
5.1	Scope	22
5.2	Application.....	22
5.3	Objective	22
5.4	Requirements for stability documentation	22
CHAPTER 6	ARRANGEMENTS FOR DETERMINING DRAFT	26
6.1	Scope	26
6.2	Application.....	26
6.3	Objective	26
6.4	Draft marks.....	26
6.5	Vessels without draft marks.....	27
ANNEX A	METHODS FOR CONDUCTING AN INCLINING EXPERIMENT OR A LIGHTSHIP MEASUREMENT	28
A1	Scope	28
A2	Application.....	28
A3	Objective	28
A4	Accuracy	28
A5	Equipment and data.....	29
A6	Preparation.....	33
A7	Experimental procedure.....	36
A8	Calculations, results and report	43
ANNEX B	GUIDANCE ON DETERMINING THE CAUSE OF ERRATIC OR EXCESSIVE DEVIATIONS IN MASS MOVEMENTS DURING AN INCLINING EXPERIMENT	56
B1	Scope	56
B2	Application.....	56
B3	Potential causes of deviations	56
B4	Graphical check	57
ANNEX C	GUIDANCE ON ACCURACY OF INCLINING EXPERIMENT, HYDROSTATIC, KN AND TANK SOUNDING DATA	58
C1	Scope	58
C2	Application.....	58

	C3	Measurements taken during an inclining experiment or lightship measurement.....	58
	C4	Stability calculations and hydrostatic and <i>KN</i> Data.....	59
	C5	Tank and cargo information.....	59
ANNEX D		METHOD FOR CONDUCTING A PRACTICAL INCLINING EXPERIMENT.....	60
	D1	Scope.....	60
	D2	Application.....	60
	D3	Objective.....	60
	D4	Elements of the method.....	60
	D5	Equipment and data.....	60
	D6	Preparation.....	62
	D7	Experimental procedure.....	63
	D8	Calculations, Results and report.....	65
ANNEX E		METHOD FOR CONDUCTING A STABILITY PROOF TEST.....	70
	E1	Scope.....	70
	E2	Application.....	70
	E3	Objective.....	70
	E4	Accuracy.....	70
	E5	Equipment and data.....	70
	E6	Preparation.....	72
	E7	Testing procedure.....	74
	E8	Calculations, results and report.....	77
ANNEX F		SPECIFICATION FOR THE FORM AND CONTENT OF A STABILITY BOOK.....	81
	F1	Scope.....	81
	F2	Application.....	81
	F3	Objective.....	81
	F4	Format of a Stability book.....	81
	F5	Content of a stability book.....	81
	F6	Vessel particulars and measurement datums.....	82
	F7	Immersion angle information.....	84
	F8	Guidance to the <i>Operator</i>	85
	F9	Loading conditions.....	88
	F10	Tank information.....	93

	F11	Cargo and stores information	94
	F12	Hydrostatic and <i>KN</i> data	94
ANNEX G		PREPARATION OF <i>KN</i> DATA AND TERMINATION OF RIGHTING LEVER CURVES (<i>G_{FZ}</i> CURVES)	97
	G1	Scope	97
	G2	Application.....	97
	G3	Objective	97
	G4	<i>KN</i> Data.....	97
	G5	Derivation of the righting lever curve (<i>G_{FZ}</i> curve)	99
ANNEX H		ABBREVIATED STABILITY CALCULATION METHODS AND PRESENTATION	101
	H1	Scope	101
	H2	Application.....	101
	H3	Objective	101
	H4	Preparation of abbreviated stability data.....	101
	H5	Presentation of the abbreviated stability calculation method.....	102
ANNEX J		GUIDANCE FOR PREPARATION OF A STABILITY NOTICE	105
	J1	Scope	105
	J2	Application.....	105
	J3	General	105
	J4	Graphical tools	105
ANNEX K		SPECIFICATION FOR THE FORMAT, POSITIONING AND MARKING OF DRAFT MARKS	106
	K1	Scope	106
	K2	Application.....	106
	K3	Objective	106
		Required outcomes	106
	K4	Ready and accurate reading of drafts	106
		Deemed-to-satisfy solutions	106
	K5	Compliance	106
	K6	Location of draft marks	107
	K7	Draft mark vertical datum.....	107
	K8	Range of draft marks to be marked.....	108
	K9	Marking of drafts	108
	K10	Recording of draft mark information	109

ANNEX L	METHOD FOR DETERMINING FREEBOARD	116
L1	Scope	116
L2	Application.....	116
L3	Objective	116
L4	Longitudinal location of freeboard measurement.....	116
L5	Vertical datum for freeboard measurement.....	116
L6	Determination of freeboard for vessels with discontinuous sheer .	117
ANNEX M	INFORMATION ON BUOYANCY AND STABILITY AFTER FLOODING	118
M1	Scope	118
M2	Application.....	118
M3	Information to be included in the stability documentation or operating manual	118
M4	Damage Control Plan	119
M5	Compliance report.....	120

CHAPTER 1 PRELIMINARY

1.1 SCOPE

This Subsection of the NSCV specifies the requirements for—

- a) stability tests conducted for the purpose of establishing and verifying a vessel's stability characteristics; and
- b) stability information provided for the use of persons who have a responsibility for the safety of the vessel.

This Subsection shall be read in conjunction with Part B—General requirements, Subsection 6A—Intact Stability Requirements and Subsection 6B—Buoyancy and Stability After Flooding.

This Subsection should also be read in conjunction with *Marine Order 504 (Certificates of operation and operation requirements — national law) 2018*.

1.2 APPLICATION

This Subsection applies to all vessels other than Special Vessels provided for in NSCV Part F of this standard, unless NSCV Part F specifies otherwise.

1.3 OBJECTIVES OF SUBSECTION 6C

The objectives of this Subsection are—

- a) to ensure that tests and calculations that are used to establish stability characteristics are sufficiently accurate to provide a true picture of the vessel's stability characteristics;
- b) to provide stability information essential to the safety of a vessel to those who have responsibility for verifying and/or maintaining the vessel's stability; and
- c) to establish a degree of standardisation in content and presentation of stability information to facilitate ready reference by those responsible for verifying and/or maintaining the vessel's stability.

NOTES:

1. There are very high risks associated with the provision of inaccurate stability information.
2. Marine Order 504 specifies requirements for operators of vessels relevant to stability.

1.4 REFERENCED DOCUMENTS

The following documents are referenced in this Subsection of the NSCV. Any document referenced should be considered to be the latest revision of the document, including amendments, unless stated otherwise.

TRANSPORT AND INFRASTRUCTURE COUNCIL

National Standard for Commercial Vessels

Part B—General Requirements

Part C—Design and Construction

Section 2: Watertight and Weathertight Integrity

Subsection 2A—Load line vessels

Subsection 2B—Non load line vessels

Section 6: Stability

Subsection 6A—Intact Stability Requirements

Subsection 6B—Buoyancy and Stability After Flooding

Part F—Special Vessels

Uniform Shipping Laws Code 1989

Section 8C—Stability

Subsection C—Stability Criteria

AUSTRALIAN MARITIME SAFETY AUTHORITY

Marine Notice No.5/2006 *The correct use of marine hydrometers*

Marine Order 504 (Certificates of operation and operation requirements — national law) 2018 (Marine Order 504)

Marine Order 505 (Certificates of competency — national law) 2022 (Marine Order 505)

INTERNATIONAL MARITIME ORGANIZATION

IMO Guidance Circular MSC/Circ.891 *Guidelines for the on-board use and application of computers.*

STANDARDS AUSTRALIA

AS 1799—*Small Pleasure Boats Code*

Part 1: General requirements for power boats

1.5 DEFINITIONS AND ABBREVIATIONS

For the purposes of this Subsection of the NSCV—

- a) The definitions provided in this clause shall apply;
- b) the following definitions provided in Part B—General Requirements of the NSCV shall apply: accommodation spaces, alter, breadth, cargo space, crew, fast craft, fishing vessel, hazard, hire and drive vessel, initial survey, length, master, measured length, National Regulator, non-passenger vessel, novel vessel, operational area, owner, passenger, passenger vessel, risk, seagoing, service category, sheltered waters, superstructure, tanker, vessel;
- c) vessel use categories (Class 1, Class 2, etc), operational area categories (Operational Area A, Operational Area B, etc) and service categories (Class 1A, Class 2A, etc) shall have the meanings specified in Part B—General Requirements of the NSCV; and
- d) the following definitions provided in Part C—Design and Construction Subsection 6A—Intact Stability Requirements shall apply: amidships,

barge, baseline, cockpit vessel, comprehensive stability criteria, crane barge, deadweight, design waterline, displacement, downflooding angle, draft at amidships, dredgings, free surface, free surface effect, hopper vessel, landing craft, length on waterline, lightship condition, lightship displacement, offshore supply vessel, open vessel, righting lever curve, ro-ro vessel, scupper, simplified stability criteria, simplified stability test, slack tank, superstructure deck, waterplane, watertight, weather deck, weathertight, well deck vessel, and windage area.

abbreviated stability calculation method—

a document that presents the outcomes of a comprehensive stability analysis in a simplified form suitable for use by operational personnel that are not themselves competent to undertake the comprehensive stability criteria calculations.

companionway—

a protected opening on a vessel leading below decks, intended to provide access for persons.

length for hydrostatics (L_H)—

either—

- a) the vessel's length on waterline (L_{DWL}); or
- b) The vessel's load line length (L_{LL}) as defined in NSCV Part C Subsection 2A.

level trim—

the waterline that lies parallel to the vessel's baseline.

NOTE: On vessels without a rake of keel, the *level trim* waterline lies parallel to the keel line.

operator—

means, for the purposes of this Subsection, the person in charge of operating the vessel, but may also include any other person on board who is responsible for assessing and/or controlling the intact stability of the vessel while in operation.

potential angle of downflooding (θ_p)—

the smallest angle of heel at which downflooding will occur, if all weathertight closing appliances that would normally be kept secured are left open.

practical inclining experiment—

an inclining experiment undertaken on a vessel in a particular condition of loading to establish the value of $G_F M_O$ in that condition.

pressed up tanks—

tanks with no voids caused by trim or inadequate venting.

NOTE: The 98 per cent condition regarded as full for operational purposes is not considered to be pressed up.

rocker—

in reference to the keel of a vessel means a keel that is not straight in profile and which curves upward at the bow and stern from a point that is at its lowest somewhere near amidships, see Figure K.1 d).

NOTE: While similar in form to sag, rocker of keel differs in that it is a design feature rather than one that is the result of structural hull deflection.

sister vessel—

two or more vessels of identical or very nearly identical general and structural arrangements.

Note: Criteria for sister vessels are specified in Clauses 3.3.5 and 4.6.

stability proof test—

a practical test whereby a vessel in a particular condition of loading is subjected to actual or simulated heeling and/or trimming moments. The responses to such influences are observed and recorded for comparison against criteria.

CHAPTER 2 REQUIRED OUTCOMES

2.1 SCOPE

This Chapter specifies required outcomes for stability tests for vessels and the provision of stability information. The required outcomes are mandatory only to the extent that they are applicable to a vessel in the relevant deemed-to-satisfy solution.

REQUIRED OUTCOMES

2.2 OPERATOR TO BE PROVIDED WITH RELEVANT INFORMATION ON STABILITY

The persons responsible for the safe operation of a vessel must be provided with the means and information required to assess and adequately control risks associated with the vessel's stability including, where appropriate, establishing safe loading conditions and monitoring changes that could adversely affect stability.

NOTE: Such measures may include a stability book, cargo information, means to sound tanks, and means to read draft marks.

2.3 ACCURACY

Data used to establish and verify the stability characteristics of a vessel must be of sufficient accuracy to ensure stability calculations made to verify the vessel's compliance against the relevant stability criteria are reliable and do not contain errors that could lead to unforeseen exposures to risk.

NOTE: Tests and calculations undertaken for stability are normally witnessed by an independent competent person to improve objectivity and reduce the likelihood of error.

2.4 RELEVANCE TO HAZARDS

Stability information provided for verifying compliance with stability criteria both initially and during operation must identify and address the types of stability-related hazards envisaged in normal and abnormal operation.

2.5 CONDITIONS OF LOADING

Stability information provided for verifying compliance with stability criteria both initially and during operation must identify and address the range of intended and/or likely loading conditions of the vessel.

2.6 LIMITS OF OPERATION

Stability information provided for verifying compliance with stability criteria both initially and during operation must establish and highlight the relevant limits of safe operation.

2.7 COMPLETENESS OF CONTENT

Stability information provided for verifying compliance with stability criteria both initially and during operation must contain sufficient information to enable stability to be readily verified against the relevant stability criteria.

2.8 STABILITY INFORMATION TO BE SUITABLE FOR USE BY THE OPERATOR

Stability information provided for use by the *operator* of a vessel must be—

- a) readily available on board at time of need; and
- b) in a form easily understood by the persons responsible for maintaining the stability of the vessel, taking into account their required levels of competence for a person in command of a vessel of that length (see Marine Order 505).

NOTE: Where, on a vessel with relatively high potential for capsize, the master has limited competence in making stability calculations to verify safe operation, abbreviated stability calculation methods allow the master a means to safely operate the vessel in all relevant conditions.

2.9 TESTING METHODOLOGY

All tests used to establish the stability characteristics of a vessel must be undertaken in a manner that achieves the required accuracy and permits subsequent independent review and verification by third parties.

DEEMED-TO-SATISFY SOLUTIONS**2.10 COMPLIANCE**

For the purpose of this National Standard, the intact stability of a vessel shall be deemed to satisfy the Required Outcomes in Clauses 2.2 to 2.9 to the extent specified by this Subsection if it complies with the relevant provisions of Chapter 3 to Chapter 5.

EQUIVALENT SOLUTIONS**2.11 ASSESSMENT METHODS**

Equivalent solutions applicable to intact stability shall be verified in a manner appropriate to the risks that would arise should the stability be found inadequate.

NOTE: Because of the high risks that arise if a vessel capsizes, assessment methods applicable to stability tend to be rigorous to promote a very high reliability of equivalence.

CHAPTER 3 METHODS FOR ESTABLISHING AND VERIFYING LIGHTSHIP PARTICULARS

3.1 SCOPE

This Chapter specifies the methods for determining or verifying the lightship particulars of a vessel; i.e. the lightship displacement, the location of the lightship vertical centre of gravity and the location of the lightship longitudinal centre of gravity.

3.2 APPLICATION

This Chapter applies to all vessels that are required to show compliance against comprehensive stability criteria (refer to Part C Subsection 6A Chapter 3).

NOTE: It may also be applied to vessels for which stability is verified against simplified stability criteria.

3.3 DETERMINATION OF LIGHTSHIP PARTICULARS

3.3.1 Application

Clause 3.3 applies to the following:

- a) Vessels for which the lightship particulars have not been established.
- b) Vessels that have been significantly altered in a way that is expected to have significantly affected the lightship particulars.
- c) Vessels for which a Lightship Measurement has shown that either the lightship displacement or the lightship LCG has altered significantly since a previous determination.

3.3.2 Determination of a vessel that has been significantly altered

For the purposes of Clauses 3.3.1b) and 3.4.1c), a vessel shall be considered to have been significantly altered if the total mass of items, added and removed exceeds 4% of the original lightship displacement.

NOTE: The mass of items added and removed need not include items replaced like-for-like such as an engine of the same model and similar power.

3.3.3 Methods for determining lightship particulars

The lightship particulars of a vessel shall be determined by the method specified in Table 1.

Table 1 — Methods for determination of lightship particulars

Criterion	Example of typical vessel	Method for determining lightship particulars	Reference
Vessels with ratio of lightship GM_o to KG of 2 or less (except sister vessels)	Monohull vessels, narrow catamarans and tri-hulls	Inclining experiment	Annex A
Vessels with ratio of lightship GM_o to KG of more than 2 (except sister vessels)	Catamarans and tri-hulls (other than narrow catamarans and tri-hulls), sailing catamarans, lighters and barges	Direct calculation of masses that comprise the lightship and Lightship Measurement	Clause 3.3.4
Sister vessels (including near sister vessels)	Production vessels	Comparison of vessels and Lightship Measurement	Clause 3.3.5

3.3.4 Vessels with large ratio of GM_o to KG

The lightship particulars shall be determined by a detailed direct calculation of the vessel's mass limited to those items that comprise the lightship where the ratio of GM_o to KG of the lightship condition would be likely to exceed 2, subject to the following conditions:

- a) The calculated values of lightship displacement and LCG shall be verified by means of a lightship measurement of the vessel in accordance with Clause 3.4.
- b) The values of lightship displacement and lightship LCG of the vessel obtained by means of the lightship measurement shall be within 2 per cent (displacement) and 1 per cent (LCG as a percentage of length) of the calculated values.
- c) Where either of these values is exceeded, the reasons for the discrepancy shall be investigated and identified and the calculated values including VCG adjusted accordingly.
- d) For the purposes of determining compliance with intact and damaged stability criteria, the value of lightship VCG shall be increased by the lesser value of—
 - i) 10 per cent of the calculated value of the lightship VCG ; or
 - ii) 0.5 metres.

NOTE: As the ratio of GM_o to KG increases beyond 2, the percentage error in GM_o obtained by means of an inclining experiment will be magnified by a factor of two or more within the calculation of the lightship VCG .

3.3.5 Sister vessels

3.3.5.1 Application

For the purposes of this Chapter, for a vessel to be considered as a sister vessel or near-sister vessel of another (the prototype vessel), the proposed sister or near-sister vessel and the prototype vessel shall comply with each of the following prerequisites:

- a) The sister vessel or near-sister vessel shall have been built to the same lines plan as the prototype vessel.
- b) The sister vessel or near-sister vessel shall be in all respects similar in profile, arrangement, construction, machinery and outfit to the prototype vessel.
- c) The lightship particulars of the prototype vessel shall have already been determined by means of either an inclining experiment, or a direct calculation of mass and lightship measurement, subject to ratio of GMO to KG , see Table 1.

3.3.5.2 **Criteria for sister vessel status**

An investigation of plans, specifications and the actual vessels shall be undertaken comparing the proposed sister vessel with the prototype to identify the nature and magnitude of differences in arrangement, construction, machinery or outfit between the two, if any.

The actual lightship displacement and LCG of the proposed sister vessel shall be determined by means of a lightship measurement; refer to Clause 3.4. The results shall be compared to those of the prototype vessel.

Provided the values of both the lightship displacement and lightship LCG of the sister vessel are within 2 per cent and 1 per cent of the respective values of the prototype vessel, the vessel shall be considered to be a true sister vessel and the lightship particulars of the sister vessel may be taken to be those of the prototype vessel without adjustment.

3.3.5.3 **Criteria for near-sister vessel status**

Where the values of lightship displacement or lightship LCG of the proposed sister vessel are greater than the values specified above, but within 4 per cent and 2 per cent of the respective values of the prototype vessel, the vessel is considered to be a near-sister vessel. The lightship particulars of the near-sister vessel shall be established by either—

- a) determining the lightship particulars by means of either an inclining experiment, or a direct calculation of mass and lightship measurement, subject to ratio of GMO to KG in Table 1; or
- b) adopting the lightship displacement and LCG values determined by the lightship measurement and estimating lightship VCG of the vessel from those of the prototype vessel in accordance with the following formula:

$$VCG_S = \frac{\Delta_P VCG_P + (\Delta_S - \Delta_P)h_{KD}}{\Delta_S} + 0.25\sqrt{(LCG_P - LCG_S)^2}$$

where

VCG_S = estimated lightship vertical centre of gravity of the near-sister vessel, in metres

Δ_P = lightship displacement of prototype vessel, in tonnes

VCG_P = lightship vertical centre of gravity of the prototype vessel, in metres

Δ_S = lightship displacement of near-sister vessel as derived from the lightship measurement, in tonnes

h_{KD} = vertical distance between the baseline and the keel amidships, in metres if $(\Delta_S - \Delta_P) < 0$

= vertical distance between the baseline and the highest deck or deckhead, in metres if $(\Delta_S - \Delta_P) > 0$

LCG_S = longitudinal centre of gravity of the near-sister vessel as derived from the lightship measurement, in metres

LCG_P = longitudinal centre of gravity of the prototype vessel, in metres

3.4 VERIFICATION OF LIGHTSHIP PARTICULARS

3.4.1 Application

This Clause applies to the following:

- a) Vessels claimed to be a sister vessel, see Clause 3.3.5.
- b) Vessels for which the lightship particulars have been derived from a mass calculation; see Clause 3.3.4.
- c) Vessels that have been altered in a way that is expected not to significantly affect the lightship particulars.
- d) Vessels that are required to undergo a periodic check of the lightship particulars.

3.4.2 Method for verification of lightship particulars

The lightship displacement and LCG of the vessel shall be determined by means of a lightship measurement undertaken in accordance with Annex A. The values of lightship displacement and LCG determined from the lightship measurement shall be compared against those previously used for the vessel's lightship.

3.4.3 Criteria for re-determination of lightship particulars

Where in Clause 3.4.1c) or d) the values of lightship displacement and lightship LCG of the vessel from the lightship measurement are more than 4 per cent (displacement) and 2 per cent (LCG as a percentage of length) of the respective values of those determined previously by an inclining experiment or direct mass calculation and lightship measurement, the lightship particulars shall be re-determined in accordance with the applicable method specified in Clause 3.3.

Where the values of lightship displacement and lightship LCG of the vessel from the lightship measurement are within 2 per cent (displacement) and 1 per cent (LCG as a percentage of length) of the respective values of those determined previously by an inclining experiment or direct mass calculation and lightship measurement, the previously determined lightship particulars shall be considered to still be valid.

Where the discrepancies of lightship displacement and lightship LCG are greater than the values specified above, but lie within 4 per cent (displacement) and 2 per cent (LCG as a percentage of length), revised lightship particulars shall be established either by—

- a) re-determining the lightship particulars in accordance with the applicable method specified in Clause 3.3; or
- b) adopting the lightship displacement and LCG values determined by the lightship measurement and estimating lightship VCG of the vessel in accordance with the following formula:

$$VCG_A = \frac{\Delta_o VCG_o + (\Delta_M - \Delta_o)h_{KD}}{\Delta_M} + 0.25\sqrt{(LCG_o - LCG_M)^2}$$

where

VCG_A = adjusted lightship vertical centre of gravity of the vessel, in metres

Δ_o = previously determined lightship displacement of the vessel, in tonnes

VCG_o = previously determined lightship vertical centre of gravity of the vessel, in metres

Δ_M = lightship displacement of vessel determined from the lightship measurement, in tonnes

h_{KD} = vertical distance between the baseline and the keel amidships, in metres if $(\Delta_M - \Delta_o) < 0$

= vertical distance between the baseline and the highest deck or deckhead, in metres if $(\Delta_M - \Delta_o) > 0$

LCG_M = lightship longitudinal centre of gravity of the vessel determined by the lightship measurement, in metres

LCG_o = previously determined lightship longitudinal centre of gravity of the vessel, in metres

CHAPTER 4 METHODS FOR CONDUCTING SIMPLIFIED STABILITY TESTS

4.1 SCOPE

This Chapter specifies the methods for conducting simplified stability tests.

4.2 APPLICATION

This Chapter applies to vessels that can apply the simplified stability criteria denoted as Chapter 7A, 7B, 7C, 7D, 7E, 8A, 8C and 8D in Part C Subsection 6A.

NOTE: No stability testing is required to verify compliance against the Chapter 7F and 8B criteria.

4.3 OBJECTIVE

The objective of this Chapter is to provide quick and practical means of establishing the vessel's compliance against simplified stability criteria where such methods can be applied without significantly reducing safety.

4.4 TYPES OF SIMPLIFIED STABILITY TESTS

Where simplified stability tests are to be applied to a vessel, the stability test method shall comply with the requirements specified in Table 2. The exception is a sister vessel that complies with Clause 4.6.

Table 2 — Application of simplified stability tests

Applicable stability criteria	Test name	Description	Reference
Chapter 7A	Practical inclining experiment	An inclining experiment that determines G_{FM0} at two or more assumed worst case ^(A) conditions of loading	Annex D
Chapter 7B Chapter 7C Chapter 8C Chapter 8D	Stability proof test	A practical test that exposes the vessel to the actual heeling moments in the worst case ^(A) conditions of loading	Annex E
Chapter 7D	AS 1799.1 Stability criteria for vessels up to 7.5 m	A practical test that exposes the vessel to the actual heeling moments in the worst case conditions of loading	AS 1799.1
Chapter 7E	AS 1799 for catamarans	A practical test that exposes the vessel to the actual heeling and trimming moments in the worst case conditions of loading	AS 1799
Chapter 8A	Sailing vessel stability proof test	A practical test that exposes the vessel to the actual sail heeling moments in the worst case conditions of loading	Annex E

KEY:

(A) For information on the required worst case conditions, refer to Subsection 6A.

4.5 STABILITY COMPLIANCE REPORT

4.5.1 General

The simplified stability test shall be documented in the form of a stability compliance report that contains the results of the test and the analysis required to show compliance with the relevant criteria.

4.5.2 Content

The content of a stability compliance report shall comprise:

- a) A description of vessel relevant to the stability criteria to be satisfied. This shall include the principal particulars and a scale drawing of the vessel.
- b) Details of the applicable stability criteria obtained from NSCV Subsection 6A.
- c) Details of the stability test performed and a record of the results achieved.
- d) Conclusions demonstrating that the stability criteria, as specified in Subsection 6A, have been met.

NOTE: Suggested formats for c) and d) applicable to the practical inclining experiment or stability proof test are shown in Table D.7 or Table E.4 respectively.

4.6 SISTER VESSELS

4.6.1 Application

For the purposes of this Chapter, for a vessel to be considered as a sister vessel of another (the prototype vessel), the proposed sister and the prototype vessel shall comply with each of the following prerequisites:

- a) The sister vessel shall have been built to the same lines plan as the prototype vessel.
- b) The sister vessel shall be in all respects identical in profile, arrangement, construction, machinery and outfit to the prototype vessel.
- c) The stability characteristics of the prototype vessel shall have already been determined by means of a simplified stability test.

4.6.2 Criteria for sister vessel status

An investigation of plans, specifications and the actual vessels shall be undertaken comparing the proposed sister vessel with the prototype to identify any differences in arrangement, construction, machinery or outfit between the two.

The drafts or freeboards of the proposed sister vessel shall be measured and compared against those of the prototype vessel when in the same condition of loading.

Provided the differences in arrangement, construction, machinery, outfit and freeboard/draft between the prototype and proposed sister vessels are not significantly different taking into account the margin, if any, by which the prototype vessel meets the minimum criteria, the proposed sister vessel shall be considered a sister vessel of the prototype vessel.

NOTE: A proposal for vessels to be considered sister vessels based on a manufacturer's quality management or internal design, production and commissioning control systems would be considered as a proposal for an equivalent solution.

CHAPTER 5 PRESENTATION OF STABILITY INFORMATION

5.1 SCOPE

This Chapter specifies the requirements for the presentation of stability information.

NOTE: Requirements for the carriage and use of stability information are specified in Marine Order 504.

5.2 APPLICATION

This Chapter applies to all vessels.

5.3 OBJECTIVE

The objective of this Chapter is to provide information on the stability of a vessel that—

- a) confirms the vessel's compliance with relevant stability criteria in Subsection 6A;
- b) allows independent verification of the vessel's compliance with the relevant stability criteria;
- c) provides the operator of the vessel and other persons responsible for the safety of the vessel with the information needed to achieve and maintain the stability of the vessel within the specified criteria; and
- d) provides the operator of the vessel and other persons responsible for the safety of the vessel with information essential for safety relevant to buoyancy and stability after flooding.

5.4 REQUIREMENTS FOR STABILITY DOCUMENTATION

5.4.1 General

The stability characteristics of a vessel shall be documented.

5.4.2 Function

The stability documentation shall incorporate the following functional documents:

- a) A stability compliance report prepared for the purpose of confirming the vessel's compliance with the relevant stability criteria and to allow independent verification if required.
- b) An *operator's* stability manual containing the information needed to safely operate the vessel in respect of its stability.

5.4.3 Accuracy

Stability information shall be sufficiently accurate to permit the vessel's compliance against the relevant stability criteria in Part C Subsection 6A to be reliably determined.

5.4.4 Relevance

Stability information shall be kept up to date to—

- a) ensure that it properly reflects the current geometric and mass characteristics of the vessel; and
- b) address the loading and potential stability hazards associated with the vessel's current operation.

NOTE: Marine Authorities normally require notification of alterations to a vessel. One reason is so the impact, if any, on the vessel's stability and stability information can be assessed.

5.4.5 Stability documentation of sister vessels

A vessel that meets the criteria for sister vessel status listed under Clauses 3.3.5 and 3.3.5.2, or Clause 4.6 may use the stability documentation for the prototype vessel to satisfy this Chapter provided—

- a) it is accompanied by a stability compliance report that establishes sister vessel status; and
- b) the stability documentation of the prototype vessel is clearly marked as being stability documentation applicable to the particular sister vessel.

NOTES:

1. This Clause does not apply to near sister vessels under Clause 3.3.5.3.
2. As well as marking on the cover and title page, reference to the sister vessel in page headers or footers would be advantageous.

5.4.6 Form of stability documentation

5.4.6.1 *Stability book*

Except as specified in Clause 5.4.6.3 a vessel shall be provided with a stability book in accordance with Annex F.

If specified in Clause 5.4.6.2, the stability book shall incorporate abbreviated stability calculation methods.

5.4.6.2 *Abbreviated stability calculation methods*

Abbreviated stability calculation methods in accordance with Annex H shall be provided where—

- a) the *operator* is required to regularly or periodically calculate or check compliance with stability criteria; and
- b) the vessel is of length specified in Table 3.

NOTE: Competencies specified for Master 45m NC or lower grade Certificate of Competency do not require them to verify stability by calculating a comprehensive loading condition, refer to Marine Order 505.

EXAMPLES:

Vessels for which the *operator* is likely to regularly or periodically calculate or check compliance with stability criteria include—

Vessels that carry cargo

Offshore supply vessels

Landing craft and other craft that carry large loads on deck

Vessels engaged in lifting

Fishing vessels with large fish holds

Table 3 — Requirement for the stability book to contain abbreviated stability calculation methods (1) (2)

Vessel use category	Operational area A	Operational area B	Operational areas C to E
Class 1 – passenger	$L_M < 35$ m	$L_M < 35$ m	$L_M < 80$ m
Class 2 – non-passenger	$L_M < 35$ m	$L_M < 35$ m	$L_M < 80$ m
Class 3 – fishing	$L_M < 35$ m	$L_M < 80$ m	$L_M < 80$ m

KEY:

(1) Only applies to vessels for which the *operator* is required to regularly or periodically calculate or check compliance against stability criteria.

(2) Notwithstanding the absence of a mandatory requirement, abbreviated stability calculation methods may be applied to stability information for all vessels as an option, provided the abbreviated method takes into account all relevant criteria.

L_M = measured length, in metres

5.4.6.3 Simplified stability documentation

The vessels that comply with each of the conditions of application specified in Table 4 may be provided with simplified stability documentation instead of the documentation specified under Clause 5.4.6.1. The simplified stability documentation shall comprise—

- a) a stability compliance report;
- b) an *operators'* stability manual comprising either the motor or sail operator's stability manual; and
- c) a stability notice listing vessel specific stability limitations posted in the operating compartment (see example in Annex J).

Table 4 — Vessels permitted to have simplified stability documentation

Conditions of application (all four to be satisfied)	Application criteria
Measured length—	< 24 metres
Applicable vessel use categories—	Class 2 or Class 3
Persons on board—	15 persons or less
But excluding—	Vessels for which the <i>operator</i> is likely to regularly or periodically calculate or check compliance against the stability criteria

5.4.6.4 Stability documentation relevant to buoyancy and stability after flooding

A vessel shall be provided with information essential for safety relevant to buoyancy and stability after flooding. The information shall be included in the vessel's *operator's* stability manual or the vessel operating manual in accordance with Annex M.

CHAPTER 6 ARRANGEMENTS FOR DETERMINING DRAFT

6.1 SCOPE

This Chapter specifies the minimum requirements for determining draft on vessels.

6.2 APPLICATION

This Chapter applies to all vessels for which the vessel's draft must be determined for the purposes of intact stability.

6.3 OBJECTIVE

The objective of this Chapter is to provide means for determining the drafts, and thereby displacement and/or trim of the vessel and for monitoring changes in these parameters.

NOTE: The safety benefits of a ready and accurate means of determining and monitoring draft, displacement and/or trim are many and varied, and will differ for different types of vessels, but may include:

- a) Establishing and verifying compliance with stability criteria, both as part of initial survey and for subsequent operations.
- b) Providing information to reduce the likelihood of grounding.
- c) Avoiding overloading, especially on vessels not provided with a load line.
- d) Maintaining minimum bow height and avoiding excessive or unfavourable trim that can impact negatively on seaworthiness.
- e) Providing a means to monitor the vessel's condition after a breach of watertight or weathertight integrity or other emergency situation.

6.4 DRAFT MARKS

The following vessels shall be provided with draft marks that comply with the requirements specified in Annex K:

- a) Vessels that are required to apply comprehensive stability criteria for the assessment of intact stability (See Subsection 6A).
- b) Vessels that have a draft of 2 m or more exclusive of an external ballast keel, lowered centreboard or skeg.
- c) Vessels that, by virtue of their operations, could exceed the limits of—
 - i) maximum draft and/or minimum bow height requirements specified in NSCV Part C Section 2;
 - ii) displacement and/or minimum draft forward to avoid slamming specified in NSCV Part C Section 3; or
 - iii) draft and/or trim for compliance with the relevant intact and damaged stability and subdivision criteria contained in this Subsection.

NOTE: Typically, such vessels carry potentially variable deadweight cargoes and may include fishing vessels with large fish holds. Deadweight cargoes are cargoes, the mass of which would be expected to load the vessel to its maximum allowable displacement or minimum allowable freeboard.

6.5 VESSELS WITHOUT DRAFT MARKS

Where draft is required on a vessel not required under Clause 6.4 to be provided with draft marks, the draft shall be measured both forward and aft by determining the freeboard to identified reference points near the ends of the vessel such as the top of the stem, end of a chine, deck at stern, underside of transom, underside of bridge deck, etc.

The drafts shall then be determined by plotting the results on an accurate profile drawing or lines plan of the vessel. Alternatively, the drafts forward and aft may be determined by means of a table provided for each reference point that lists the draft and corresponding freeboard at regular intervals.

NOTES:

1. Draft may be required to determine displacement and thereby compliance with Chapter 7A simplified stability criteria contained in Subsection 6A.
2. Accuracy of the profile drawing or lines plan is verified by checking key dimensions against measurements of the actual vessel.

ANNEX A METHODS FOR CONDUCTING AN INCLINING EXPERIMENT OR A LIGHTSHIP MEASUREMENT

A1 SCOPE

This Annex describes the experimental methods for conducting an inclining experiment or a lightship measurement.

It forms a normative part of this Subsection for the purposes of a deemed-to-satisfy solution.

NOTE: The term 'experiment' as distinct from 'inclining experiment' means either inclining experiment or lightship measurement.

A2 APPLICATION

This Annex shall apply to vessels required by Clause 3.3 to undergo an inclining experiment or lightship measurement.

NOTES:

1. An inclining experiment is used to establish the lightship displacement, *LCG* and *VCG*. A lightship measurement is undertaken as part of an inclining experiment.
2. A lightship measurement is used to establish the lightship displacement and *LCG*.

A3 OBJECTIVE

The objective of this Annex is to specify experimental methods that are deemed to satisfy the requirements of this Standard by providing results of sufficient accuracy to be used in verifying compliance with criteria, avoiding or reducing the likelihood of systemic or random errors.

A4 ACCURACY

The procedures and equipment used for the experiment shall be such as to facilitate measurements of sufficient accuracy to achieve adequately reliable results. Measures shall be taken to ensure that any uncertainties and/or errors, if and when they occur, are likely to underestimate the stability of the vessel.

NOTES:

1. Guidance on appropriate values for the accuracy of measurements is given in Annex C.
2. Errors tend to be cumulative. Potential sources of errors include the following:
 - a) The accuracy of hydrostatic calculations and tank capacity calculations based on the Simpson's Rule or other rules for integration.
 - b) The accuracy of the verification of the inclining masses, and of the measuring of the distances moved by their centres of gravity at each mass movement.
 - c) The accuracy of the reading of the drafts. This is governed by the accuracy with which the draft marks have been 'cut in', and by the water conditions when the readings are being taken.
 - d) The accuracy of the measurement of the pendulum effective lengths and measurement of the pendulum deflections.
 - e) Difficulties in accurately ascertaining the masses of 'items on' and 'items off'.

- f) Unaccounted for free surface, or overestimates of free surface.
- g) Changes that might occur in the waterplane area as the vessel heels.

A5 EQUIPMENT AND DATA

A5.1 Application

The minimum requirements for equipment and data for use in the experiment shall be as specified in Table A.1.

Table A.1—Requirements for equipment and data

Requirement	Lightship Measurement	Inclining Experiment
The vessel	Clause A5.2	Clause A5.2
Reference data	Clause A5.3	Clause A5.3
Inclining masses	Not required	Clause A5.4
Arrangements for moving inclining masses	Not required	Clause A5.5
Means for measuring angles of inclination	Not required	Clause A5.6
Hydrometer	Clause A5.7	Clause A5.7
Means and methods for reading draft marks and/or freeboards	Clause A5.8	Clause A5.8
Means for reading tank or bilge soundings or ullages	Clause A5.9	Clause A5.9

NOTE: Equipment additional to that specified above may facilitate meeting the requirements for accuracy specified in Clause A4; for example, scales that could be used to determine the masses of equipment and personnel.

A5.2 The vessel

The vessel shall be complete in respect of its lightship with all structure, machinery, outfit and equipment on board. The condition of the vessel shall be such that all the lightship items not already present on vessel are able to be accounted for. For the purposes of this clause, complete means that the total of 'Items On' shall be no more than 2 per cent of the calculated lightship displacement.

NOTES:

1. Refer to the definition of lightship in Subsection 6A for information on what constitutes the lightship.
2. Vessels that have a total 'Items On' exceeding 2 per cent of the calculated lightship displacement at the time of inclining would be considered as a proposal for an equivalent solution.

A5.3 Reference data**A5.3.1 Application**

The data specified in Table A.2 shall be available for reference at the time of the lightship measurement or inclining experiment.

Table A.2—Requirements for reference data

Requirement
General arrangement drawing
Lines plan
Location of draft marks
Tank calibration data
Hydrostatic data
Geometric load line (if applicable)

A5.3.2 Standards of accuracy

Measures shall be taken to ensure that all data collated in preparation for stability tests and calculations is of sufficient accuracy to yield results that are reliable and auditable.

NOTES:

1. Marine authorities usually require independent verification of key elements of data used for establishing stability e.g. draft marks and lines plans.
2. Guidance for determining the accuracy of hydrostatic, KN data and tank sounding data are specified in Annex C.

A5.4 Inclining masses**A5.4.1 Quantity**

The total quantity of inclining masses provided for the inclining experiment shall be sufficient to achieve a maximum angle of heel with all the mass along one side of the vessel of between 2 degrees and 4 degrees, on either side of the upright.

NOTES:

1. An estimate of the initial metacentric height (GFM_0) of the vessel at inclining is normally made so that the inclining mass required can be determined.
2. Where determination of GFM_0 is uncertain, provision of additional inclining masses may be advisable in advance to ensure a satisfactory angle of heel is achieved on the day of the inclining.
3. Maximum angles of heel between 1 degree and 2 degrees would be considered as a proposal for an equivalent solution giving special consideration to the reasons why heel to at least 2 degrees might be impractical and other factors that might impact on accuracy (see Annex C).

A5.5 Arrangements for moving inclining masses

Suitable means shall be provided to safely and readily move the inclining masses across the deck of the vessel during the inclining experiment.

A5.6 Means for measuring angles of inclination

A5.6.1 Number of means for measuring angles of inclination

The number of means for measuring angles of inclination used for an inclining experiment shall not be less than the number specified in Table A.3.

NOTE: Multiple means of measuring reduce the likelihood of error.

Table A.3 — Minimum number of means for measuring angles of inclination

Determining factors	Minimum number of pendulums
Vessels of 20 m or more in measured length	2 (A)
All other vessels	1 (B)

KEY:

- (A) A digital inclinometer complying with Clause A5.6.3 is an alternative deemed-to-satisfy solution for use as the second pendulum.
- (B) The use of either two pendulums or a pendulum and a digital inclinometer provides a means of improving accuracy where only a pendulum of relatively short length can be used due to the configuration of the vessel.

A5.6.2 Pendulums

A.5.6.2.1 Length of pendulum

The pendulums shall be as long as practicable to maintain the accuracy of the experiment. Where the length of the pendulum between the pivot point (see Clause A.5.6.2.2) and the marking strip (see Clause A.5.6.2.3) is less than 1500 mm, special measures shall be applied to prevent inaccuracies; see Clauses A4 and Annex C.

A.5.6.2.2 Pendulum line and point of attachment

The pendulum line shall be of a material that does not kink or twist when under the load of the pendulum. The top connection of the pendulum shall allow unrestricted rotation of the pendulum line about the pivot point.

EXAMPLE:

A pendulum line of strong, smooth, good quality braided string or fishing line attached to a washer that is suspended from a nail (see Figure A.1)

NOTE: The pendulum will tend to oscillate for a period after each movement of inclining masses and also from any slight movements of the vessel due to wake, wind, etc. This effect of such oscillations can be reduced and the accuracy of readings improved by dampening each pendulum in liquid as shown in Figure A.1.

A.5.6.2.3 Arrangements for marking of readings

A horizontal marking strip shall be provided at the lower end of each pendulum for marking the position of the pendulum line following each movement of the inclining masses.

The marking strip shall be aligned athwartships and close to the pendulum line but not in contact with it.

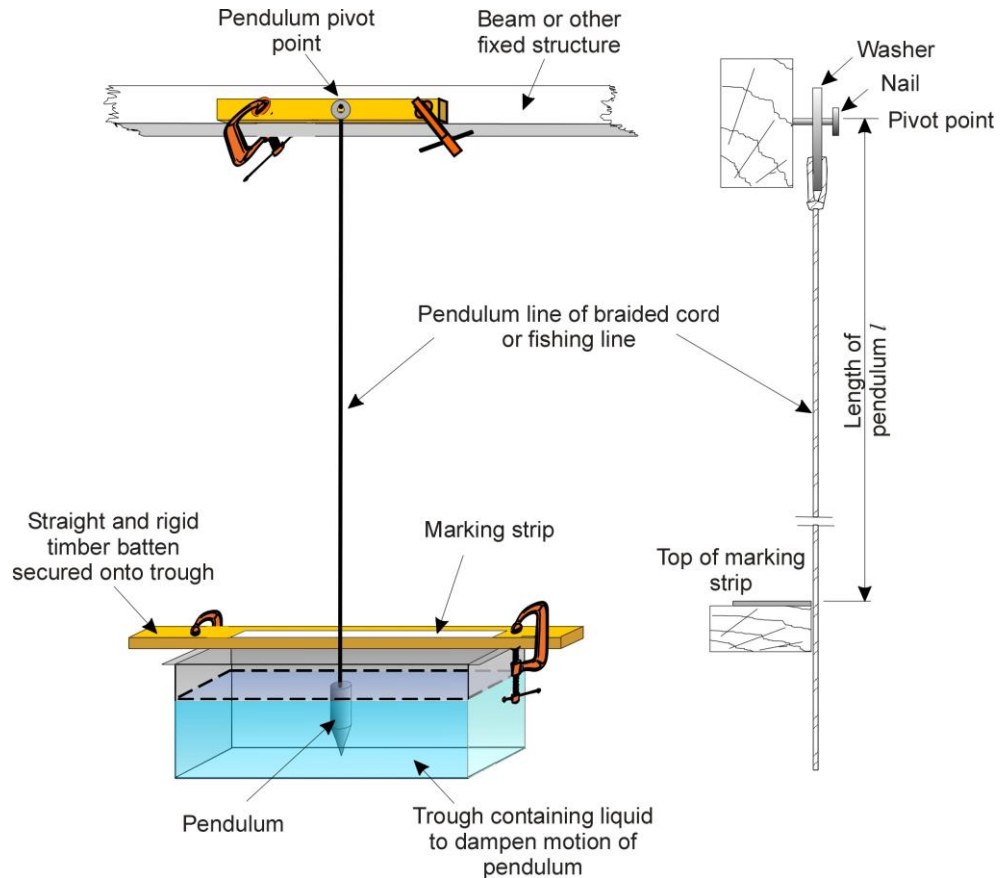

Figure A.1— Example of a pendulum arrangement

A5.6.3 Digital inclinometer

A digital inclinometer shall allow readings to be taken of accuracy consistent with the requirements of Clause A4. The readings shall be recorded to enable subsequent review and analysis. The digital inclinometer shall have a certificate verifying that it has been calibrated within the five years preceding the date of the inclining experiment.

NOTE: Table A.3 indicates the extent to which a digital inclinometer is a deemed-to-satisfy solution.

A5.7 Hydrometer

A relative density hydrometer with a range sufficient to cover the anticipated density of the water in which the vessel will be measured shall be provided to measure the density of the water during the experiment. The hydrometer shall—

- a) be of glass construction;
- b) not have any signs of damage; and
- c) have a certificate verifying that it has been calibrated within the five years preceding the date of the inclining experiment.

NOTES:

1. Refer to Marine Notice 5/2006 for further information on the types and uses of hydrometers.
2. Metal hydrometers are no longer usually being accepted for calibration by the National Measurement Institute.

A5.8 Means and methods for reading draft marks and/or freeboards

Means shall be provided and/or methods used to facilitate the accurate reading of draft marks and/or freeboards on both sides of the vessel without affecting the trim or angle of heel of the vessel.

NOTES:

1. A small boat may be necessary to allow personnel to accurately read the draft marks during the inclining experiment.
2. A throttled transparent plastic tube can facilitate the reading of draft marks by damping out water surface movement.

A5.9 Means for reading tank or bilge soundings or ullages

Means shall be provided to facilitate the accurate reading of tank or bilge soundings or ullages.

NOTE: Sounding tapes or sounding rods and information on the location of the sounding pipe relative to the longitudinal datum at the measured sounding are normally required to allow accurate readings to be made.

A6 PREPARATION**A6.1 Application**

The preparatory steps specified in Table A.4 shall be satisfied prior to undertaking the lightship measurement or inclining experiment.

Table A.4—Requirements for preparation

Requirement	Lightship Measurement	Inclining Experiment
Control of the experiment	Clause A6.2	Clause A6.2
Limitations on persons on board	Clause A6.3	Clause A6.3
Berthing of the vessel	Clause A6.4	Clause A6.4
List	Not required	Clause A6.5
Trim	Not required	Clause A6.6
Free surface of tanks and bilges	Not required	Clause A6.7
Removal of unnecessary items	Clause A6.8	Clause A6.8
Location of inclining masses	Not required	Clause A6.9

Location of pendulum(s)

Not required

Clause A6.10

A6.2 Control of the experiment

A competent person shall be nominated to be in charge of the experiment. The person in charge shall—

- a) have responsibility for providing equipment, making preparations, conducting the procedure, recording the data, and calculating the results; and
- b) have the authority to control the personnel carrying out the experiment.

NOTE: Normally the person in charge is a representative of the designer or builder of the vessel, or a consultant naval architect contracted for the purpose on behalf of the owner.

A6.3 Limitations on persons on board

Only crew or personnel that are participating directly in the experiment shall be on board the vessel during the conduct of the experiment.

NOTE: The results of the experiment will be invalidated if the magnitude and location of mass on the vessel (including persons and fluids) during the experiment is not strictly controlled.

A6.4 Berthing of the vessel

The vessel shall be berthed such that, during the experiment—

- a) the vessel will be in a protected position where it will be not be adversely affected by wind (particularly beam winds), tide, waves or currents;
- b) the depth of water at the berth is sufficient to ensure that the vessel does not ground at any time during the experiment; and
- c) the vessel can float free from contact with the wharf or from hanging up on tight mooring lines.

A6.5 List

The initial list of the vessel shall not exceed 0.5 degrees from the vertical. Masses on board shall be distributed so as to plumb the vessel upright prior to commencement of the inclining experiment, but see Clause A7.15.

A6.6 Trim

The trim of the vessel shall be adjusted such that the waterplane area of the vessel does not significantly change during the course of the inclining experiment.

EXAMPLE:

Most modern tugs and oil rig supply vessels, landing craft, and the majority of modern fishing vessels have hard chines and or wide flat sterns that can significantly affect the accuracy of the results if they become immersed or emerge during an inclining experiment.

NOTES:

1. The significance of changes in waterplane area is determined by a comparison of the transverse moment of inertia of the waterplane in the upright and maximum inclined conditions.
2. Trim may be adjusted by the location of inclining masses, additional solid ballast of verified mass and/or liquid in ballast tanks. The total quantity of liquids on board may be limited by Clause A6.7.
3. If chine immersion is impractical, an alternative procedure could be developed and assessed as an equivalent solution.

A6.7 Free surface of tanks and bilges

Unless otherwise specified in this Clause, tanks and bilges shall be pumped dry.

Where one or more tanks are not empty, the total mass of tank contents on the vessel shall be the lesser of—

- a) that necessary to provide for essential services and/or essential ballasting; and
- b) 20 per cent of the lightship mass.
- c) While the total contents of tanks during the experiment shall be kept to the absolute minimum, tanks used for essential ballasting and/or essential services that cannot be empty during the conduct of the inclining experiment shall be pressed full.

NOTES:

1. Large quantities of liquid on the vessel during an inclining can introduce significant errors in the final calculation of lightship particulars.
2. Errors in the determination of tank soundings, the density of tank contents and tank particulars can become a determining factor when the mass of liquids is relatively large compared to the lightship.
3. The presence of free surface in tanks or bilges, even those that are nominally full or empty, can also seriously affect the accuracy of the inclining experiment and may result in the vessel not meeting the deviation check requirements specified in Clauses A7.14 m) and A8.2.
4. Clause A8.5.2 provides that, for tanks assumed to be full or empty and for bilges, no correction can be made for free surface when determining the lightship KG_0 .
5. Special care is needed when filling fuel oil tanks or sewage tanks to prevent accidental pollution.

A6.8 Removal of unnecessary items

Masses on board the vessel that are neither a part of the lightship nor essential for the conduct of the experiment shall be reduced to an absolute minimum before the experiment.

NOTE: Such masses may include but are not limited to tools and tool boxes; welding equipment; staging; sand; debris, liquids within tanks and other spaces and other temporary material on board.

A6.9 Location of inclining masses

A6.9.1 Mass groups

The total quantity of inclining mass shall be divided into four roughly equivalent inclining masses. The smallest of these inclining masses shall

not be less than 50 per cent of the largest. The mass, *VCG* and *LCG* of each group shall be accurately ascertained.

NOTE: Normally, masses used for an inclining experiment are weighed on calibrated scales such as a weighbridge to ensure sufficient accuracy.

A6.9.2 Location of masses

The inclining masses shall be accurately arranged along each side of the vessel with their centre of gravity a distance approximately $d/2$ each side of the centre line where d is the distance between the centres of gravity of the inclining masses on each side of the vessel, see Figure A.2.

NOTE: While other arrangements of inclining masses may be considered, that described is the most efficient in terms of maximum angle of heel attained and the accuracy of measured lever.

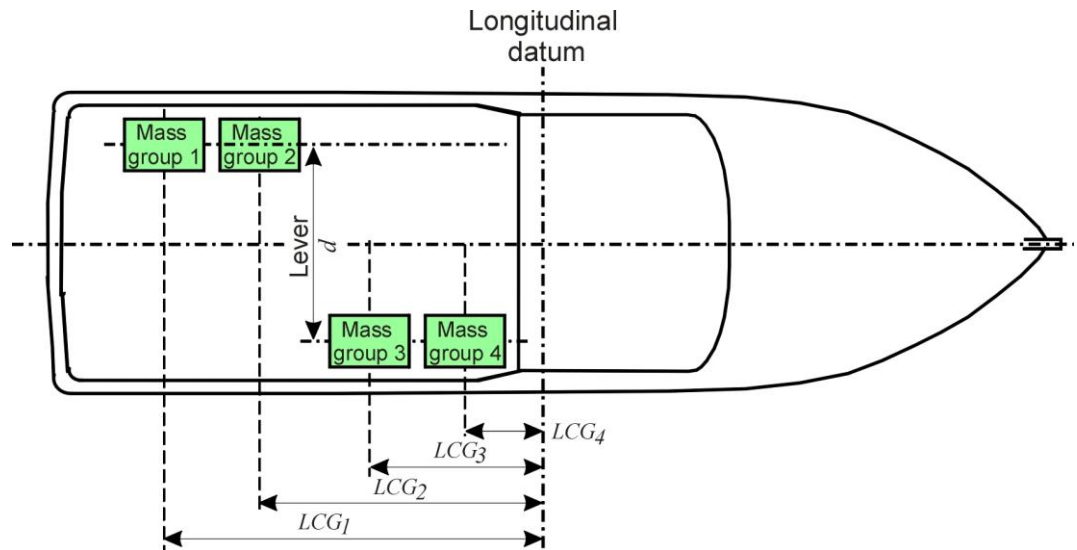

Figure A.2— Inclining masses

A6.10 Location of pendulum(s)

Pendulums shall be located on the vessel such that—

- they are protected from the effects of wind and air movements;
- they are remote from the ends and sides of the vessel;
- satisfactory effective pendulum lengths can be obtained;
- suitable arrangements can be provided for setting up marking strips; and
- there is sufficient space to enable the pendulum deflections to be marked without incurring parallax error.

A7 EXPERIMENTAL PROCEDURE

A7.1 Application

The experimental procedure specified in Table A.5 shall be applied when undertaking the experiment.

Table A.5—Requirements for experimental procedure

Requirement	Lightship Measurement	Inclining Experiment
Confirm suitability of environmental conditions	Clause A7.2	Clause A7.2
Confirm vessel in ready state	Clause A7.3	Clause A7.3
Freedom of vessel movement	Clause A7.4	Clause A7.4
Control of personnel	Clause A7.5	Clause A7.5
Recording of inclining masses	Not required	Clause A7.6
Testing of pendulums and recording of pendulum data	Not required	Clause A7.7
Ascertaining and recording of 'items on' and 'dry items off'	Clause A7.8	Clause A7.8
Ascertaining and recording of 'liquid items off'	Clause A7.9	Clause A7.9
Recording of permanent solid ballast	Clause A7.10	Clause A7.10
Measurement of water density	Clause A7.11	Clause A7.11
Measurement of drafts and freeboards	Clause A7.12	Clause A7.12
Sequence of mass movements	Not required	Clause A7.13
Measuring and recording mass and pendulum movements	Not required	Clause A7.14
Check for indicators of potential instability	Not required	Clause A7.15

A7.2 Confirm suitability of environmental conditions

The person in control of the experiment shall confirm that the environmental conditions are satisfactory for conduct of the experiment, taking into account the need for the vessel to be free to move and the effect of movement on the accuracy of readings taken during the course of the experiment. The following factors shall be considered when deciding whether the experiment should be commenced or aborted:

- a) The magnitude, direction and variability of any winds.
- b) The magnitude and direction of currents and tides.
- c) The rate of any precipitation and the ability of the decks to quickly and completely drain rainwater.
- d) The presence of any waves or frequent wake waves from passing craft.
- e) The magnitude of ripples on the water surface.

NOTE: The undertaking of an inclining experiment in unsuitable conditions runs a real risk of failing the pendulum deviation tests specified in Clauses A7.14 m) and A8.2.

A7.3 Confirm vessel in ready state

The person in control of the experiment shall confirm that the vessel is in a ready state for conduct of the experiment, taking into account the potential for error and the need for accuracy of readings taken during the course of

the experiment. The following factors shall be confirmed prior to commencement of the experiment:

- a) Moveable masses, loose gear, shipyard plant and staging, where practicable, have been removed from the vessel and those items, that must remain on board have been secured against movement.
- b) Steps have been taken to remove all liquids in tanks and bilges that are not essential to the immediate needs of the vessel or the conduct of the experiment.
- c) The initial list of the vessel does not exceed 0.5 degrees from the vertical.
- d) All control valves for heeling and trimming tanks and cross-flooding connections have been securely closed.
- e) All pumps not required for essential services have been shut down.

A7.4 Freedom of vessel movement

The person in control shall ensure that the vessel is free to move during the experiment. Such steps shall include—

- a) removal and stowage of any gangway leading to shore during the inclining experiment;
- b) verification that there will be sufficient depth of water over the period of the experiment to ensure the vessel continues to float free of the sea bed; and
- c) slackening of mooring lines to prevent contact with the wharf or hanging up as mooring lines tighten.

NOTE: Should occasional contact with the wharf still occur after slackening mooring lines, the vessel may be pulled free from the wharf and let drift during each measurement.

A7.5 Control of personnel

The person in control of the experiment shall ensure—

- a) all persons not engaged in the experiment have left the vessel;
- b) the person in charge of the engine room has been notified that the experiment is beginning, and that no fluid handling of any kind is to take place throughout the experiment; and
- c) all persons on board for the purpose of carrying out the experiment understand their duties and the positions they must take up while the pendulums are being read.

NOTE: Person masses and their positions are recorded for inclusion with the 'dry items off'.

A7.6 Recording of inclining masses

The person in control of the experiment shall establish, confirm and record the mass, *VCG*, *LCG* and *TCG* of the individual inclining masses or mass groups.

NOTES:

1. This might include sighting of weighbridge certificates, the use of calibrated scales or other evidence that accurately establishes mass.
2. A diagram similar to that shown in Figure A.2 will assist in recording the essential particulars of inclining masses or mass groups.

A7.7 Testing of pendulums and recording of pendulum data

The person in control of the experiment shall establish that the pendulums are free to swing throughout the heeling of the vessel. The effective lengths of the pendulums shall be recorded.

A7.8 Ascertaining and recording of 'items on' and 'dry items off'

The person in control of the experiment shall inspect the vessel to ascertain all items yet to go on and dry items to be removed for the purposes of determining the lightship characteristics. The masses of all 'items on' and 'dry items off' (items off other than liquids) shall be ascertained by weighing, established from supplier's data or where these are not practicable, estimated by other means.

The vertical and longitudinal positions of their individual centres of gravity shall be determined with the aid of the general arrangement plan. A detailed record of all items to go on and items to go off shall be recorded including the mass, *VCG* and *LCG* of each item.

NOTE: Typical table templates for items on and dry items off are given in Table A.11 and Table A.12.

A7.9 Ascertaining and recording of 'liquid items off'

The person in control of the experiment shall inspect the vessel to ascertain the state of all tanks and spaces on the vessel that may contain liquids. The inspection shall confirm whether all bilges, void spaces and tanks that are designated as empty are in fact dry by either visual inspection or, where visual inspection is not practicable, by soundings. Soundings or ullage readings are to be taken of all tanks and spaces that contain liquids and the data together with the estimated specific gravity of the contents recorded.

NOTES:

1. A typical table template for liquid items off is given in Table A.13.
2. Soundings or ullage readings will later be corrected for trim.
3. A hydrometer can be used to measure the specific gravity of tank contents if there is uncertainty as to the specific gravity of tank contents that could result in significant inaccuracies in the experiment results.

A7.10 Recording of permanent solid ballast

On vessels where permanent solid ballast is fitted, the masses and centres of gravity of the ballast in each stowage position shall be recorded.

NOTE: Calculation of the lightship condition includes any permanent solid ballast fixed in position. The recording of solid ballast on board during the experiment is important for future reference.

A7.11 Measurement of water density

The density of the actual body of water within which the vessel is floating at the time of the experiment shall be measured using the hydrometer. The number of readings shall be sufficient to accurately determine the average density of the water displaced by the hull. A single reading taken from a depth approximately equal to one half the as-measured draft of the vessel shall be the minimum deemed-to-satisfy requirement unless expressly stated otherwise in Table A.6. Where more than a single reading is taken, the water density for the purpose of the experiment shall be the arithmetic mean of the readings.

NOTE: Additional measurements will improve accuracy particularly in tidal rivers and estuarine waters after rain.

Table A.6 — Minimum deemed-to-satisfy readings of water density

Criterion	Minimum requirement for measurement of specific gravity
Measured length \geq 30 m	Specific gravity to be read using water samples taken at each end of the vessel
As inclined draft \geq 2.5 m	Specific gravity to be read from water samples taken at just below the water surface and at approximate draft to lowest point of keel

A7.12 Measurement of drafts and freeboards

The drafts forward and aft shall be read directly from the draft marks both port and starboard. Drafts port and starboard amidships or, where no drafts are marked, freeboards to the loadline or deck shall be measured and recorded where required to—

- a) determine the initial list of the vessel; and
- b) determine the correction, if any, for hog or sag on the following—
 - i) vessels that exhibit either hog or sag in their keel or sheer-line;
 - ii) planked wooden vessels of 20 m or more in measured length; or
 - iii) other vessels of 40 m measured length or more.

NOTE: Measuring and recording drafts or freeboards amidships and freeboards at bow and stern provides a useful means to double check the 'as measured' waterline.

A7.13 Sequence of mass movements

The vessel shall be inclined by moving the inclining masses or mass groups following a sequence that—

- a) attains an angle of inclination not less than 2 degrees nor greater than 4 degrees each side of upright;
- b) ensures that not less than two widely differing pendulum readings are recorded on each side of upright condition; and
- c) records on at least two occasions any residual deflection that may arise when inclining masses are returned to their initial locations.

The deemed-to-satisfy sequence of mass movements is specified in Table A.7, see also Figure A.2.

The heeling of the vessel by the movement of the inclining masses shall be a continuous process without break.

Table A.7 — Deemed-to-satisfy sequence of mass movements

Move	Mass group (see Figure A.2)	Direction	Description
1	1	Port ⇒ Starboard (1)	Intermediate heel to starboard (1)
2	2	Port ⇒ Starboard	Maximum heel to starboard
3	1 + 2	Starboard ⇒ Port	Nominal return to upright
4	3	Starboard ⇒ Port	Intermediate heel to port
5	4	Starboard ⇒ Port	Maximum heel to port
6	3 + 4	Port ⇒ Starboard	Nominal return to upright

KEY:

(1) The sequence of mass movements may commence Starboard ⇒ Port provided subsequent mass movements are adjusted accordingly.

A7.14 Measuring and recording mass and pendulum movements

The mass movements, pendulum readings, pendulum deflections, X_z , running average and final average errors shall be recorded in a table similar to Table A.14.

All personnel involved in the inclining experiment shall take up their designated positions for the initial pendulum reading, and the zero positions of each pendulum shall be marked on its marking strip.

For each of the mass movements 1 to 6 specified in the sequence of mass movements Table A.7, the following procedure shall apply:

- a) Carry out the inclining mass movement.
- b) Confirm and record the distance d_z the inclining mass has been moved, in metres.
- c) If the vessel's lifting gear is being used, securely re-stow the lifting gear.
- d) If shore gear is being used, uncouple the lifting hook.
- e) Recall the inclining party members to their pendulum reading positions.
- f) Make certain that all moorings are slack and that the vessel is clear of the berth.
- g) Allow time for the vessel to steady.
- h) When the pendulum(s) are steady, record their positions on the marking strips and the time of the reading.
- i) Measure the distance of this pendulum position from the previous pendulum position, which is the pendulum deflection a_z .

- j) Determine, for each pendulum, heeling moment/pendulum deflection X_Z value obtained from the following formula:

$$X_Z = \frac{w_Z d_Z}{a_Z}$$

where

X_Z = heeling moment/pendulum deflection for mass movement Z

w_Z = magnitude of inclining mass moved for mass movement Z, in tonnes

d_Z = the transverse distance the inclining mass has been moved for mass movement Z, in metres

a_Z = the pendulum deflection measured from the previous pendulum position for mass movement Z, in metres.

NOTE: $w_Z d_Z$ is the heeling moment.

- k) After inclining mass movements 2 and 5, check that the maximum angle of heel lies between the minimum and maximum allowed values, see also Clause A7.15 b).
- l) After inclining mass movements 2 to 6, determine the deviation from running average δ_Z obtained from the following formula:

$$\delta_Z = 100 \left(\frac{X_Z - \bar{X}_{Z-1}}{\bar{X}_{Z-1}} \right)$$

where

δ_Z = percentage deviation from running average for mass movement Z

X_Z = heeling moment/pendulum deflection for mass movement Z

\bar{X}_{Z-1} = the running average value of X_Z for mass movement Z-1

$$= \frac{X_1 + \dots + X_{Z-1}}{Z-1}$$

- m) Check that the value of the deviation from running average for the particular inclining mass movement δ_Z does not exceed 5 per cent.
- n) If the deviation is greater than 5 per cent then a check should be made to establish the cause of the deviation, see also Clause A7.15. If the check fails to reveal a cause that would invalidate the experiment, then upon correction, the applicable mass movement shall be repeated until the value of δ_Z is less than 5 per cent.

NOTE: Guidance on typical causes for excessive deviations are listed in Annex B

- o) Repeat the procedure steps a) to n) until all six inclining mass movements have been completed.

A7.15 Check for indicators of potential instability

The inclining experiment shall be immediately discontinued if any of the following are observed during the course of the inclining experiment:

- a) The pendulum zero checks are erratic.
- b) The pendulum deflections are greater than might have been expected.
- c) There is an inconsistency in the values of the pendulum deflections for equal mass movements in opposite directions.
- d) The vessel appears to have an unexplained initial list that cannot be corrected.

NOTE: The above discrepancies could mean that the vessel is initially unstable, i.e. it could have a negative initial metacentric height (GM_0) value. The experiment should not recommence until the cause of the discrepancy can be established and appropriate measures taken. See Annex B for guidance.

A8 CALCULATIONS, RESULTS AND REPORT**A8.1 Application**

The calculations as specified in Table A.8 shall be applied when undertaking the experiment.

Table A.8 — Requirements for calculations

Requirement	Lightship Measurement	Inclining Experiment
Final deviation check	Not required	Clause A8.2
Hydrostatic data used in the calculations	Clause A8.3	Clause A8.3
Determination of 'as measured' displacement	Clause A8.4	Clause A8.4
Determination of 'as measured' vertical centre of gravity (VCG)	Not required	Clause A8.5
Determination of the 'as measured' longitudinal centre of gravity (LCG)	Clause A8.6	Clause A8.6
Calculation of the lightship condition particulars	Clause A8.7	Clause A8.7
Report	Clause A8.8	Clause A8.8

A8.2 Final deviation check

On completion of all the mass movements, the final average value of X_Z for all readings shall be calculated and recorded (see Table A.14) and the final average error δ_T obtained, as a percentage, from the following formula:

$$\delta_{TZ} = 100 \left(\frac{X_Z - \bar{X}_T}{\bar{X}_T} \right)$$

where

$$\delta_{TZ} = \text{percentage average deviation for mass movement } Z$$

X_Z = heeling moment/pendulum deflection for mass movement Z

\bar{X}_T = the average value of X_Z for all mass movements

Except in those cases specified in Table A.9, if the deviation from final average of any one reading δ_T exceeds 5 per cent, the results shall be considered insufficiently accurate for the purposes of calculating compliance against the stability criteria.

NOTE: This may necessitate a review of the procedure and the conduct of a new inclining experiment.

Table A.9 — Adjustments for certain inclining experiment deviations that exceed 5 per cent

Number of pendulums used	Number of pendulums affected	Number of deviations exceeding 5%	Direction of deviation	Adjustment
2	1	1	δ_{TZ} is +ve	Eliminate particular deflection reading from calculations
2	1	1 or 2	δ_{TZ} is -ve	Use all deflection readings in calculations
1	1	1	δ_{TZ} is -ve	Use all deflection readings in calculations

A8.3 Hydrostatic data used in the calculations

A8.3.1 Source of hydrostatic data

The hydrostatic values (i.e. displacement (Δ), vertical centre of buoyancy (KB), longitudinal centre of buoyancy (LCB) and transverse metacentric height above baseline (KM_o)) at inclining shall be determined from hydrostatics derived from the same source as those provided in the stability book.

NOTE: Using hydrostatics calculated using a different hull definition to that used in the hydrostatics that verify stability can introduce significant errors into the calculations.

A8.3.2 Trim values

To avoid significant inaccuracies in the calculations, the hydrostatic data to be used shall have been determined at trim values representative of the 'as measured' condition. To this end, the hydrostatic data shall be—

- derived specifically for the 'as measured' trim of the vessel;
- subject to Clause A8.3.3, interpolated between two sets of hydrostatic data calculated at different trims either side of the 'as measured' trim; or
- subject to Clause A8.3.3, at a particular trim that differs from the 'as measured' trim.

A8.3.3 **Limits on the use of hydrostatic data at a trim that differs from the ‘as measured’ trim**

Hydrostatic data derived at a trim that differs from the ‘as measured’ trim may be used for the purposes of Clause A8 if the difference in trim does not exceed the following value:

$$\delta_t = \frac{L_H}{F_t}$$

where

δ_t = the difference in trim between the hydrostatic data and the ‘as measured’ vessel over the *length for hydrostatics*, in metres

L_H = the *length for hydrostatics*, in metres

F_t = the trim factor as specified in Table A.10

Table A.10 — Trim factors F_t

Hull description	Anticipated operating stability characteristics	F_t	
		Clause A8.3.2b)	Clause A8.3.2c)
Similar shaped waterlines at bow and stern throughout the relevant range of trims (1)(2)	Marginal or near-marginal (4)	50	75
	Conservative (5)	40	50
Significantly different waterlines at bow and stern during one or more occasions through the relevant range of trims (1)(3)	Marginal or near-marginal (4)	100	150
	Conservative (5)	75	100

KEY:

- (1) The relevant range of trims is that between the trim used for the hydrostatic data and the ‘as measured’ trim of the vessel.
- (2) Typically bulk carriers, tankers, coasters, conventional cargo vessels, and many fishing vessels of older design.
- (3) Typically oil rig supply vessels, tugs, ro-ro vessels, planing vessels and many modern fishing vessels.
- (4) Marginal means one or more stability characteristics of the vessel in any operating condition of loading lies at or very close to a specified stability criterion.
- (5) Preliminary stability calculations shall be undertaken that confirm that the vessel should easily meet all relevant stability criteria in all likely conditions of loading.

A8.4 **Determination of ‘as measured’ displacement**

A8.4.1 **Adjustment for water density**

The ‘as measured’ displacement derived from the hydrostatics shall be adjusted for the average density of the actual body of water within which

the vessel is floating at the time of the experiment, as recorded in Clause A7.11.

A8.4.2 Correction for hog or sag

If amidships measurements are specified in Clause A7.12b), the displacement calculation shall be adjusted for any hog or sag of the vessel's hull. The correction to the displacement Δ shall be derived from the following formula:

$$C_{HS} = 75(D_{HS} \times TPC)$$

where

C_{HS} = correction to displacement for hog (–ve) or sag (+ve), in tonnes

D_{HS} = measured hog (–ve) or sag (+ve), in metres

$$= T_{MA} - T_{MN}$$

where

T_{MA} = the actual measured draft amidships, in metres.

T_{MN} = the calculated draft amidships assuming no hog or sag, in metres

TPC = the tonnes per centimetre immersion of the hull at draft T_{MN}

A8.4.3 Calculation of 'as measured' displacement

The 'as measured' displacement shall be determined as follows—

$$\Delta_M = \left(\frac{\rho_M}{\rho_H} \right) \Delta_H + C_{HS}$$

where

Δ_M = the 'as measured' displacement, in tonnes

ρ_M = the average specific gravity of the buoyant body of water 'as measured'; see Clause A8.4.1

ρ_H = the specific gravity assumed in the derivation of the hydrostatic data

Δ_H = the displacement from the hydrostatic data corresponding to the 'as measured' draft and trim (see Clause A8.3.2), in tonnes

C_{HS} = correction to displacement for hog (–ve) or sag (+ve) (see Clause A8.4.2), in tonnes

A8.5 Determination of 'as measured' vertical centre of gravity (VCG)

A8.5.1 Calculation of metacentric height (G_FMo)

The metacentric height (G_FMo) determined from each pendulum, for the vessel at inclining shall be obtained using the following formula:

$$G_F M_O = \bar{X}_T \left(\frac{l}{\Delta_M} \right)$$

where

$G_F M_O$ = the initial 'fluid' metacentric height (i.e. reduced by free surface effects) as determined for a particular pendulum, in metres

\bar{X}_T = the average value of X_Z for all mass movements, calculated in accordance with Clause A8.2, in tonnes

l = the pendulum length in metres

Δ_M = the 'as measured' displacement from Clause A8.4.3, in tonnes

The metacentric height $G_F M_O$ for the vessel at inclining is the mean of the individual values of $G_F M_O$ calculated for each pendulum.

A8.5.2 Correction for free surface effects

Where tanks contain liquids that are not pressed up, a correction for free surface may be applied for liquids of known amount in calibrated tanks. No free surface correction shall be claimed for liquids in bilges, tanks that are pressed full or for residual liquids in the bottom of tanks that are considered dry.

The free surface value to be used in calculations shall be derived using the smallest transverse moment of inertia of the liquid surface within each tank—

- a) assuming the 'as measured' trim; and
- b) over the range of angles of heel attained during the inclining; and
- c) applying the relative density of the liquid when the inclining experiment was conducted.

The correction for free surface (FSC) to be applied to $G_F M_O$ shall be obtained from the following formula:

$$FSC = \frac{\sum FSM}{\Delta_M}$$

where

FSC = correction for free surface, in metres

FSM = the free surface moment for each slack tank, corrected for density of contents, in tonne metres

Δ_M = the 'as measured' displacement from Clause A8.4.3, in tonnes

The initial metacentric height in the solid condition 'as measured' shall be obtained from the following formula:

$$GM_o = G_F M_o + FSC$$

where

GM_o = the initial metacentric height in the solid condition, i.e. without free surface effects, in metres

$G_F M_o$ = metacentric height for the vessel 'as measured', in metres

FSC = correction for free surface, in metres

A8.5.3 Calculation of the vertical centre of gravity (VCG)

The vertical centre of gravity above baseline shall be obtained from the following formula:

$$VCG = KM_o - GM_o$$

where

VCG = the vertical centre of gravity above baseline in the 'as measured' condition, in metres

KM_o = the initial transverse metacentric height above baseline in the 'as measured' condition obtained from the hydrostatic data (see Clause A8.3.1), in metres

GM_o = the initial metacentric height in the solid condition, i.e. without free surface effects, in metres

A8.6 Determination of the 'as measured' longitudinal centre of gravity (LCG)

The 'as measured' LCG shall be determined as follows:

- a) When the LCG lies vertically (perpendicular to the waterplane) above the LCB specified in the hydrostatic data where—
 - i) the hydrostatic data is derived at the 'as measured' trim; or
 - ii) the hydrostatic data at the 'as measured' trim is derived from interpolating between two sets of hydrostatic data at trims above and below the 'as measured' trim.
- b) When the vessel as measured has trim the location of the LCG shall be derived from the LCB adjusted for the trimming effect of the height of the VCG above the VCB as follows:

$$LCG = LCB - \frac{(100 \times t_\delta \times MTI \text{ cm})}{\Delta_M} + (VCB - VCG) \left(\frac{t_\delta}{L_H} \right)$$

where

LCG = the location of the longitudinal centre of gravity of the 'as measured' vessel, in metres

LCB = the location of the longitudinal centre of buoyancy of the vessel from the hydrostatic data at the 'As measured' draft, in metres

t_{δ} = the trim difference between the 'as measured' trim and the trim of the hydrostatic data (-ve if actual trim is more by the bow than trim at which hydrostatic data was calculated), in metres

$MCTI_{cm}$ = the moment to change trim 1 cm from the hydrostatic data at the 'As measured' draft, in tonne-metres per centimetre

Δ_M = the 'as measured' displacement of the vessel determined from Clause A8.4.3, in tonnes

VCG = the vertical centre of gravity of the vessel 'as measured' determined from Clause A8.5.3, in metres

VCB = the vertical centre of buoyancy of the vessel from the hydrostatic data at the 'as measured' draft, in metres

L_H = the length of vessel specified for the hydrostatic data, in metres

A8.7 Calculation of the lightship condition particulars

A8.7.1 Totals of items on, dry items off and liquid items off

The totals for 'items on', 'dry items off' and 'liquid items off' in Clauses A7.8 and A7.9 shall be calculated, see Table A.11, Table A.12, and Table A.13.

A8.7.2 Adjusting the 'as measured' particulars to derive the lightship

The totals of 'items on', 'dry items off' and 'liquid items off' shall be used to adjust the 'as measured' particulars of the vessel to yield the lightship particulars.

NOTE: A typical table for calculating the lightship particulars is given in Table A.15.

A8.8 Report

A8.8.1 Experiment to be recorded

The inclining experiment or lightship measurement shall be recorded in a report. The report shall contain all information necessary to allow independent review of the results.

NOTE: A report that describes each of the matters specified in Clauses A4, A6, A7 and A8 would satisfy this Clause.

A8.8.2 Content of report

The experiment report shall include the following information:

- a) Date, time and place of the experiment.
- b) The wind, weather, tidal and sea conditions.
- c) The vessel's heading and mooring conditions.

- d) The names and designations of those carrying out the experiment and the total number of persons on board.
- e) The particulars of the vessel in accordance with Clause A8.8.3.
- f) The particulars of the experiment in accordance with Clause A8.8.4.

A8.8.3 Particulars of the vessel

The following particulars of the vessel, where appropriate shall be included in the inclining report:

- a) The measured length (L_M)
- b) The length for hydrostatics (L_H)
- c) Breadth (B)
- d) Depth (D)
- e) Thickness of the keel plate or depth of keel at amidships.
- f) Thickness of the deck stringer plate at side at amidships.
- g) The designed rake of keel, if any, used in calculations. The rake of the keel shall be shown in a diagram with forward and aft perpendiculars clearly indicated.
- h) Longitudinal position of the forward and aft draft marks relative to the respective forward and aft perpendiculars. A sketch or table shall be provided for clarity.
- i) Longitudinal position of amidships based on the length for hydrostatics (L_H) relative to the nearest frame.
- j) Frame spacing. Where frame spacing is not uniform throughout the vessel's length, details shall be shown on a dimensioned diagram.

A8.8.4 Information from the inclining experiment or lightship measurement

The following information obtained from the experiment shall be included in the report:

- a) All readings and measurements recorded during the experiment shall be in the units in which they were measured.
- b) All the calculations made using the readings and measurements to determine the lightship particulars: displacement, vertical centre of gravity (VCG) and longitudinal centre of gravity (LCG).
- c) For inclining experiments, the calculations shall include a statement of the maximum angle of heel achieved during the inclining of the vessel.
- d) A statement of the percentage of the lightship displacement represented by the liquids onboard during the experiment.
- e) Where the experiment report is not already incorporated as part of a stability booklet, the report shall also include:
 - i) a diagram showing the vessel's general arrangement;
 - ii) hydrostatic information;

iii) tank calibration data; and

iv) free surface information.

NOTE: A lines plan and general arrangement plan are normally also provided to accompany the experiment report if required for the purposes of independent verification.

Table A.11 — Items to go on

Items on	Mass (tonnes)	Centre of gravity above baseline (metres)	Vertical moment above baseline (tonne-metres)	Centre of gravity from amidships (metres)	Longitudinal moment about amidships (+ve or -ve) (tonne-metres)
TOTAL ITEMS ON					

Table A.12 — Dry items off

Items off	Mass (tonnes)	Centre of gravity above baseline (metres)	Vertical moment above baseline (tonne-metres)	Centre of gravity from amidships (+ve or -ve) (metres)	Longitudinal moment about amidships (+ve or -ve) (tonne-metres)
TOTAL DRY ITEMS OFF					

Table A.13 — Contents of tanks (liquid items off)

Tank	Content	Sounding or ullage reading (metres)	Reading corrected for trim (metres)	Relative density	Mass (tonnes)	Centre of gravity above baseline (metres)	Vertical moment above baseline (tonne-metres)	Centre of gravity from amidships (+ve or -ve) (metres)	Longitudinal moment about amidships (tonne-metres)	Actual free surface moment (tonne-metres)
TOTAL LIQUID ITEMS OFF										

Table A.14 — Mass movements and readings for each pendulum

PENDULUM NUMBER			LENGTH OF PENDULUM (metres)								
Time	Mass movement <i>Z</i>	Direction of mass movement $P \Rightarrow S$ or $S \Rightarrow P$	Mass (<i>w_Z</i>) (tonnes)	Distance mass moved <i>d_Z</i> (metres)	Resulting heeling moment <i>w_Zd_Z</i> (tonne-metres)	Pendulum reading (metres)	Pendulum deflection <i>a_Z</i> (metres)	<i>X_Z</i> Value (tonne-metres/metre)	Running average deflection \bar{X}_{Z-1} (metres)	Deviation from running average δZ (%)	Deviation from final average δTZ (%)
	Initial										
	1										
	2										
	3										
	4										
	5										
	6										
							TOTAL				
							FINAL AVERAGE \bar{X}_T				

Table A.15 — Calculation of the lightship particulars

Item	Mass (tonnes) (-ve for items off)	VCG above baseline (metres)	Vertical moment above baseline (tonne-metres)	LCG from amidships (metres)	Longitudinal Moment about amidships (tonne-metres)
Vessel 'as measured'					
Items on					
Dry items off					
Liquid items off					
LIGHTSHIP					

ANNEX B GUIDANCE ON DETERMINING THE CAUSE OF ERRATIC OR EXCESSIVE DEVIATIONS IN MASS MOVEMENTS DURING AN INCLINING EXPERIMENT

B1 SCOPE

This Annex provides guidance on the causes of erratic or excessive deviations in mass movements observed during an inclining experiment.

B2 APPLICATION

This Annex applies to inclining experiments conducted on vessels in accordance with Annex A or Annex D. The Annex is informative. It is referred to in Clauses A7.14n) and A7.15.

B3 POTENTIAL CAUSES OF DEVIATIONS

Table B.1 gives guidance as to potential causes of deviations encountered during the course of an inclining experiment.

Table B.1 — Potential causes of deviations

Description	Possible reason	Remedy
Mass movements 3 and 6 fail to return all the way back to upright. Ratios of pendulum deflection to inclining moment resulting from mass movements 2 and 5 are larger than those from mass movements 1 and 4.	Progressive shift of liquids from one side of the vessel to another.	Check and close cross connections of tanks.
Mass movements 3 and 6 fail to return all the way back to upright. Ratios of pendulum deflection to inclining mass moment resulting from mass movements 1 and 4 are larger than those from mass movements 2 and 5.	Vessel may be aground.	Check depth of water against draft. Move vessel to deeper water or reschedule for higher tide.
Ratios of pendulum deflection to inclining mass moment resulting from mass movements on one side of the vessel are larger than those on the other.	Vessel may be hung up on wharf or mooring lines.	Check vessel free of wharf and mooring lines slack.
Vessel unable to be set upright initially, Mass movements 3 and 6 fail to return to upright.	Vessel may have an angle of loll, i.e., negative G_{FM_0} in the upright condition.	Check for large unaccounted for free surface, insufficient depth of water, less than anticipated stability.
Deflections larger than anticipated.	Vessel may have lower G_{FM_0} than anticipated or heeling moment larger than anticipated.	Check for large unaccounted for free surface, errors in recorded inclining mass or distance inclining masses moved, less than anticipated stability.

B4 GRAPHICAL CHECK

A plot of pendulum reading against inclining mass moment can provide a means for quickly checking for problems during the inclining experiment. Points plotted on the graph should be collinear. The application of the methodology is illustrated in **Error! Reference source not found.** to Figure B.4.

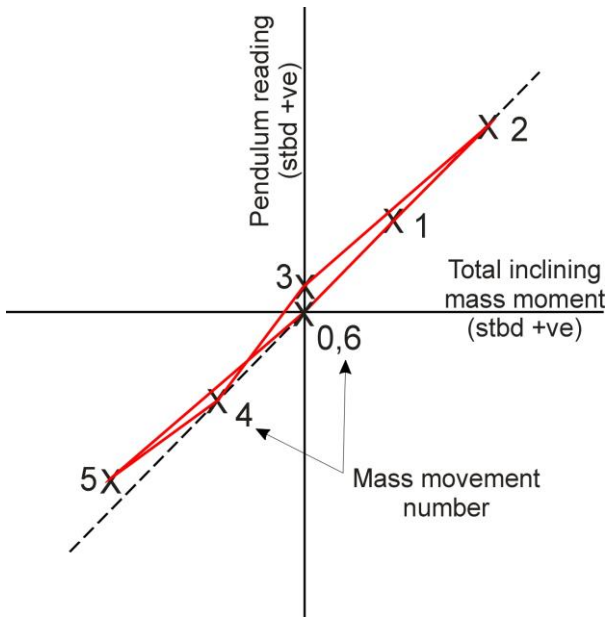

Figure B.4—Gusting wind from port side

NOTE: Redo mass movements 3 and 5

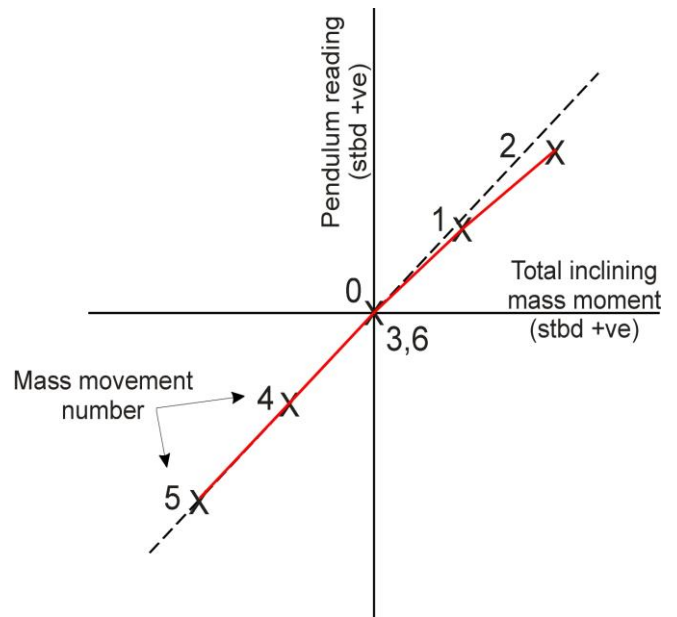

Figure B.3—Vessel touching bottom or restrained by mooring lines

NOTE: Take water depth soundings. Check Lines. Redo mass movements 1 and 2

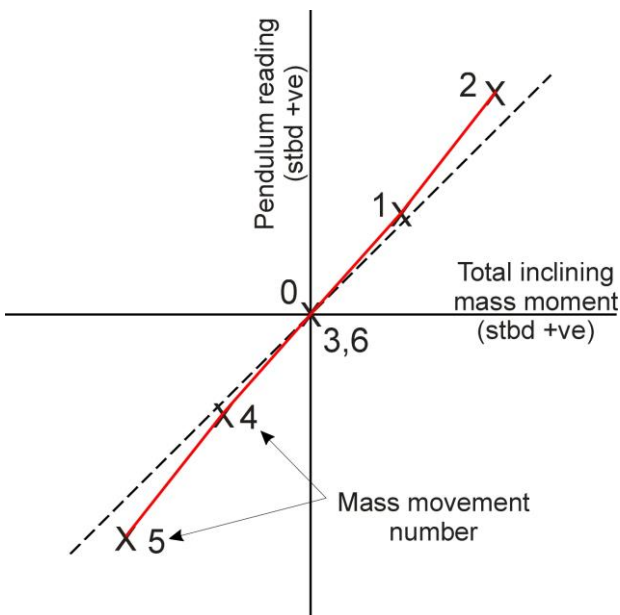

Figure B.1—Excessive free liquids

NOTE: Recheck all tanks and voids. Pump out as necessary. Redo all mass movements and recheck freeboard and draft readings.

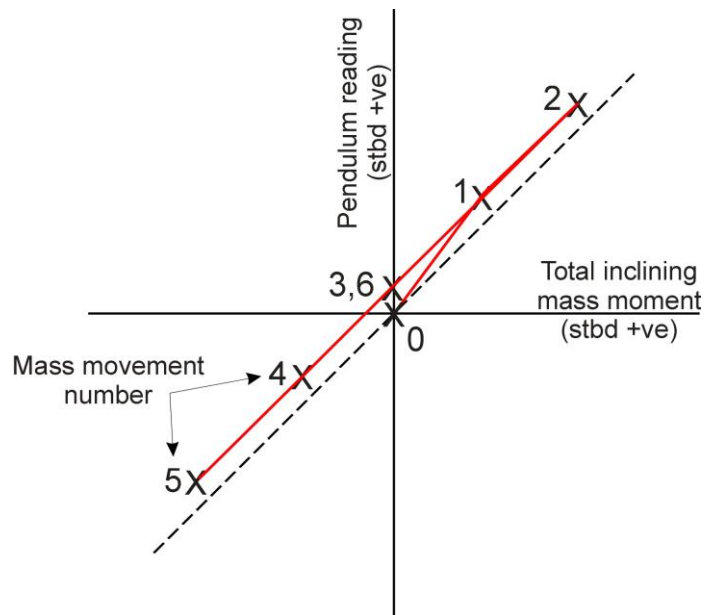

Figure B.2—Steady wind from port side after initial reading

NOTE: Plot may be acceptable depending upon number of pendulums and percentage deviations

ANNEX C GUIDANCE ON ACCURACY OF INCLINING EXPERIMENT, HYDROSTATIC, *KN* AND TANK SOUNDING DATA

C1 SCOPE

This Annex provides guidance on appropriate values of accuracy for the measurements conducted during an inclining experiment or lightship measurement and the presentation of hydrostatic data, *KN* data and tank sounding data.

C2 APPLICATION

This Annex is informative. It is referred to in Clauses A4, A5.3.2, A5.4.1 and A5.6.2.

C3 MEASUREMENTS TAKEN DURING AN INCLINING EXPERIMENT OR LIGHTSHIP MEASUREMENT

For the results of an inclining experiment or lightship measurement to be reliable, care is needed to ensure that all measurements taken are sufficiently accurate. The equipment and procedures used should provide levels of precision not less than those specified in Table C.1.

Table C.1 — Inclining Experiment Measurement Accuracy

Measurement	Recommended maximum tolerance	Remarks
Freeboard and draft marks	\pm the greater of 5 mm or $\frac{\Delta_M}{20 TPC}$ mm where Δ_M = displacement in the 'as measured' condition, in tonnes TPC = tonnes per centimetre at the inclined draft	Equates to an error in the lightship displacement of ± 0.5 per cent for large vessels and a larger error on small vessels. An under measurement in the lightship displacement will likely overestimate the lightship GM_O of the vessel.
Pendulum lengths (P)	± 0.5 per cent of the pendulum length	An over measurement of the pendulum length will overestimate the lightship GM_O of the vessel.
Pendulum deflections (δ)	$\pm \frac{P \alpha}{3600}$ mm where P = pendulum length, in millimetres α = maximum angle of heel during the inclining, in degrees	Equates to an error in pendulum readings of ± 1.5 per cent for the maximum deflection and approximately ± 3.0 per cent for intermediate mass movements. An under measurement in the pendulum reading will overestimate the lightship GM_O of the vessel.
Inclining masses	± 1 per cent of the mass	An over measurement of the mass of inclining masses will overestimate the lightship GM_O of the vessel.
Tank soundings	± 5 mm	An under measurement of the contents of tanks during an inclining will likely overestimate the lightship GM_O of the vessel.

C4 STABILITY CALCULATIONS AND HYDROSTATIC AND *KN* DATA

Stability calculations and tabular presentations of hydrostatic and *KN* data should have an order of accuracy in accordance with Table C.2

Table C.2 — Recommended rounding off of calculations and data

Vessel measured length	Displacement or mass t	TPC t	Lengths <i>KM, KB, LCG,</i> <i>VCG, KN</i> m	Moment <i>FSM</i> tm	<i>MCT1cm</i> tm
Less than 7 m	0.001	0.001	0.01	0.001	0.001
7 m to less than 25 m	0.01	0.001	0.01	0.01	0.001
25 m to less than 55 m	0.1	0.01	0.01	0.1	0.01
55 m to less than 120 m	1	0.1	0.01	1	0.1
120 m or more	5	1	0.01	5	1

NOTE: The above values generally keep rounding off errors associated with the key stability parameters at less than 1% with the exception of lengths, in particular *G_{FZ}* values calculated from *KN* data. While in practice these rounding off errors should be relatively small compared to potential errors from other sources (such as measurements or determination of lightship particulars), reducing the rounding off error by a decimal may be necessary to show that a vessel with marginal stability still does in fact meet the applicable minimum stability criteria.

C5 TANK AND CARGO INFORMATION

Tabular presentations of tank and cargo information should have an order of accuracy not less than that specified in Table C.3 .

Table C.3 — Rounding off of tank and cargo sounding data

Vessel measured length	Mass t	Linear dimensions Sounding, Ullage, <i>VCG, LCG, LCA</i> m	Moment <i>FSM</i> tm
Less than 7 m	0.001	0.01	0.001
7 m to less than 25 m	0.01	0.01	0.01
25 m to less than 55 m	0.1	0.01	0.1
55 m to less than 120 m	1	0.01	1
120 m or more	5	0.01	5

NOTE: The above values generally keep rounding off errors associated with the key stability parameters at less than 1% and are sufficient for determining stability compliance. However, there may be other operational reasons why a smaller value of rounding off may be appropriate, especially for data pertaining to smaller tanks.

ANNEX D METHOD FOR CONDUCTING A PRACTICAL INCLINING EXPERIMENT

D1 SCOPE

This Annex specifies the procedure for undertaking a practical inclining experiment.

It forms a normative part of this Subsection for the purposes of a deemed-to-satisfy solution.

D2 APPLICATION

This Annex shall apply to vessels required by Clause 4.4 to undergo a practical inclining experiment. The procedure applies to each condition of loading specified by the criteria to be analysed.

NOTE: A practical inclining experiment is used to establish the actual value of G_{FM0} in simulated likely worst case conditions of loading.

D3 OBJECTIVE

The objective of this Annex is to specify a simplified method for determining stability while providing sufficient accuracy to achieve results that are valid.

D4 ELEMENTS OF THE METHOD

The experimental method applied to a practical inclining experiment is similar to that contained for an inclining experiment as specified in Annex A but with modifications. This Annex contains five elements as specified in Table D.1 that apply to each loading condition to be tested.

Table D.1— Structure of this Annex

Element	Applicable clause
Accuracy	As per Clause A4
Equipment and data	Clause D5
Preparation	Clause D6
Experimental procedure	Clause D7
Calculations, results and report	Clause D8

D5 EQUIPMENT AND DATA

D5.1 Application

Requirements for equipment and data used in the practical inclining experiment are specified in Table D.2.

Table D.2—Requirements for equipment and data

Requirement	Reference
The vessel	Clause D5.2
Reference data	Clause D5.3
Inclining masses	As per Clause A5.4
Arrangements for moving inclining masses	As per Clause A5.5
Means for measuring angles of inclination	As per Clause A5.6
Means and methods for reading draft marks and/or freeboards	As per Clause A5.8
Means for reading tank or bilge soundings or ullages	As per Clause A5.9

NOTE: Equipment additional to that specified above may facilitate meeting the requirements for accuracy specified in Clause D4 (that refers to Clause A4); for example scales that could be used to determine the masses of equipment and personnel.

D5.2 The vessel

The vessel shall be complete in respect of its lightship with all structure, machinery, outfit and equipment on board, see also Clause D6.2.

D5.3 Reference data

D5.3.1 Application

The data specified in Table D.3 shall be available for reference at the time of the practical inclining experiment.

Table D.3—Requirements for reference data

Requirement
General arrangement drawing
Tank calibration data
Displacement of the vessel

D5.3.2 Displacement of vessel

The 'as inclined' displacement shall be established by one of the following methods:

- a) Direct weighing of the vessel lightship displacement using a calibrated scale such as a weighbridge and adjusting for the mass of deadweight items.
- b) Determining the lightship displacement as per the lightship measurement under Annex A and adjusting for the masses of deadweight items and inclining weights.

- c) Determining the 'as inclined' displacement by establishing the draft and using hydrostatics in a manner similar to undertaking a lightship measurement under Annex A.

NOTE: Determining the displacement by means of draft marks adds additional steps in the process (see Clauses A5.3, A5.6.3, A7.11, A8.3, A8.4).

D5.3.3 Standards of accuracy

Measures shall be taken to ensure that all data collated in preparation for the practical inclining experiment and calculations is of sufficient accuracy to yield results that are reliable and auditable.

NOTE: Marine authorities usually require independent verification of key elements of data used for establishing stability.

D6 PREPARATION

D6.1 Application

The preparatory steps specified in Table D.4 shall be satisfied prior to undertaking the practical inclining experiment.

Table D.4—Requirements for preparation

Requirement	Reference
Control of the experiment	As per Clause A6.2
Limitations on persons on board	As per Clause A6.3
Berthing of the vessel	As per Clause A6.4
List	As per Clause A6.5
Trim	See Note
Loading of the vessel	Clause D6.2
Tanks and bilges	Clause D6.3
Removal of unnecessary items	Clause D6.4
Location of inclining masses	As per Clause A6.9
Location of pendulum(s)	As per Clause A6.10

NOTE: Refer to the prerequisite requirements for application of the applicable simplified criteria contained in NSCV Subsection 6A that limit their application to vessels for which the waterplane area does not alter significantly over the range of operational drafts.

D6.2 Loading of the vessel

The vessel shall be loaded to simulate the required loading condition specified in relevant criteria in NSCV Subsection 6A as closely as practicable in respect of—

- a) displacement;
- b) location of the vertical centre of gravity;
- c) location of the total longitudinal centre of gravity (i.e., the trim); and

d) free surface in tanks partly filled with consumables.

The 'as inclined' loading shall be adjusted to result in the required displacement notwithstanding the presence of inclining weights on board. Where necessary, other items of deadweight may be substituted by known weights of the same mass located at the same *VCG* and *LCG*, but subject to the presence of sufficient free surface to simulate the effect of consumables in tanks that are considered to be partially filled.

NOTE: Known differences between the vertical location of inclining masses during the practical inclining experiment and those of the required loading condition may be accounted for by a mathematical correction to the value of G_{FM0} determined by the experiment, see Clause D8.3.

D6.3 Tanks and bilges

Bilges and tanks not required to be fully or partially filled for the purposes of the experiment shall be pumped dry.

Notwithstanding the requirements of the criteria, tanks that do not contain consumables and which are used for essential ballasting shall be pressed full.

NOTES:

1. The presence of excessive free surface in tanks or bilges, even those that are nominally full or empty, can seriously affect the accuracy of the practical inclining experiment and may result in the vessel not meeting the deviation check requirements specified in Clauses A7.14 m) and A8.2.
2. The purpose of the practical test is to determine the G_{FM0} of the vessel in actual operational conditions of loading. A vessel that has excessively large free surface within tanks in the operational condition may have difficulty meeting the requirements for the running and final deviation checks. The stability of such vessels may need to be established by other methods.

D6.4 Removal of unnecessary items

Masses on board the vessel that are neither representative of the vessel in the specified loading condition nor essential for the conduct of the experiment shall be reduced to an absolute minimum before the experiment.

NOTE: Such masses may include but are not limited to tools and tool boxes; welding equipment; staging; sand; debris; liquids within tanks and other spaces and other temporary material on board.

D7 EXPERIMENTAL PROCEDURE

D7.1 Application

D7.2 The experimental procedure specified in Confirmation and recording of 'as inclined' condition of the vessel

The person in control of the experiment shall inspect the vessel to confirm that the vessel in the 'as inclined' condition properly simulates the required condition of loading. The vessel's condition of loading at the time of the practical inclining experiment shall be recorded. Where weights are simulated, the mass, *VCG* and *LCG* of each item shall also be recorded.

Table D.5 shall be applied when undertaking the practical inclining experiment.

D7.3 Confirmation and recording of ‘as inclined’ condition of the vessel

The person in control of the experiment shall inspect the vessel to confirm that the vessel in the ‘as inclined’ condition properly simulates the required condition of loading. The vessel’s condition of loading at the time of the practical inclining experiment shall be recorded. Where weights are simulated, the mass, *VCG* and *LCG* of each item shall also be recorded.

Table D.5—Requirements for experimental procedure

Requirement	Reference
Confirm suitability of environmental conditions	As per Clause A7.2
Confirm vessel in ready state	As per Clause A7.3
Freedom of vessel movement	As per Clause A7.4
Control of personnel	As per Clause A7.5
Recording of inclining masses	As per Clause A7.6
Testing of pendulums and recording of pendulum data	As per Clause A7.7
Confirmation and recording of ‘as inclined’ condition of the vessel	Clause D7.3
Ascertaining and recording of liquids	Clause D7.4
Recording of permanent solid ballast	As per Clause A7.10
Measurement of freeboard when upright	Clause D7.5
Sequence of mass movements	As per Clause A7.13
Measuring and recording mass and pendulum movements	As per Clause A7.14
Check for indicators of potential instability	As per Clause A7.15

D7.4 Ascertaining and recording of liquids

As part of the procedure specified in Clause D7.3, the person in control of the experiment shall inspect the vessel to ascertain the state of all tanks and spaces on the vessel that may contain liquids. The inspection shall confirm whether all bilges, void spaces and tanks that are designated as empty are in fact dry by either visual inspection or, where visual inspection is not practicable, by soundings. Soundings or ullage readings are to be taken of all tanks and spaces that contain liquids and the data together with the estimated specific gravity of the contents recorded.

NOTES: A typical table template for recording the contents of tanks is given in Table A.13.

D7.5 Measurement of freeboard when upright

The freeboard of the vessel both port and starboard when in the upright condition shall be measured in accordance with Annex L. The readings port and starboard shall be compared. Where they differ, the readings shall be used to determine the magnitude of the initial list of the vessel.

D8 CALCULATIONS, RESULTS AND REPORT**D8.1 Application**

The calculations as specified in Table D.6 shall be applied when undertaking the practical inclining experiment.

Table D.6 — Requirements for calculations

Requirement	Reference
Final deviation check	As per Clause A8.2
Calculation of 'as inclined' metacentric height (G_{FM_0})	Clause D8.2
Corrections to G_{FM_0} for variation in the VCG of inclining masses	Clause D8.3
Stability compliance report	Clause D8.4

D8.2 Calculation of 'as inclined' metacentric height (G_{FM_0})

The metacentric height (G_{FM_0}) determined from each pendulum, for the vessel at inclining shall be obtained using the following formula:

$$G_{FM_0} = \bar{X}_T \left(\frac{l}{\Delta_M} \right)$$

where

G_{FM_0} = the initial 'fluid' metacentric height (i.e. reduced by free surface effects) as determined for a particular pendulum, in metres

\bar{X}_T = the average value of X_Z for all mass movements, calculated in accordance with Clause A8.2, in tonnes

l = the pendulum length in metres

Δ_M = the 'as inclined' displacement from Clause D5.3.2, in tonnes

The metacentric height G_{FM_0} for the vessel at inclining is the mean of the individual values of G_{FM_0} calculated for each pendulum.

D8.3 Corrections to G_{FM_0} for variation in the VCG of inclining masses

Where the VCG of the inclining masses differs from that of the items that they replace, the value of G_{FM_0} shall be corrected by the following formula:

$$G_F M_O + \frac{w_T \delta_H}{\Delta_M}$$

where

$G_F M_O$ = the 'as inclined' metacentric height, in metres

w_T = the total inclining mass, in tonnes

δ_H = The height of the total inclining mass above the masses that would have been on board in the condition of loading had the inclining masses not been aboard, in metres (–ve if below)

Δ_M = the 'as inclined' displacement from Clause D5.3.2, in tonnes

No modification shall be made to $G_F M_O$ for free surface present on the vessel during the practical inclining experiment.

D8.4 Stability compliance report

The practical inclining experiment shall be recorded in a stability compliance report. The report shall contain the relevant calculations to enable the vessel's stability to be compared against the relevant minimum stability criteria. The report shall contain all information necessary to allow independent review of the results.

NOTE: A typical format for a practical inclining experiment given in Table D.7.

Table D.7—Stability compliance report for a practical inclining experiment

Name of vessel:				Date:
Place of practical inclining experiment:				
Principal dimensions:	L_M		B	
Vessel type:	Flush deck		Well deck	
	Cockpit deck		Open	
Owner of vessel:				
Builder of vessel:				
Proof test conducted by:				
Independent witness:				
State of weather:				
Mooring arrangements:				

(Continued)

Table D.7 (Continued)

Inclining masses		Diagram of inclining masses on vessel:	
Group 1:	tonnes	<p>The diagram shows a horizontal line representing the vessel's deck. Four rectangular masses are positioned along this line, labeled 1, 2, 3, and 4 from left to right. Masses 1 and 2 are on the upper half of the line, while masses 3 and 4 are on the lower half. A vertical double-headed arrow on the left side of the line is labeled 'Lever', indicating the vertical distance between the upper and lower horizontal levels.</p>	
Group 2:	tonnes		
Group 3:	tonnes		
Group 4:	tonnes		
Pendulums			
No.1	Length: mm	Location:	
No. 2 (if used)	Length: mm	Location:	
Loading condition to be simulated:			
State of bilges:			
State of equipment:			
State of fuel tanks:			
State of FW tanks:			
State of sullage tanks:			
State of other tanks:			
State of cross connections:			
Mass & location of permanent ballast:			
As inclined displacement, tonnes:			
Method and calculations used to determine 'as inclined' displacement:			
Minimum freeboard when upright, in mm:			
Measured to (refer to Annex L):			
Location from bow or stern, in metres:			
Vessel breadth at that point, in metres:			
Draft to bilge emergence, in mm:			
Measured at which point:			
Vessel breadth at that point, in metres:			
A record of mass movements and pendulum deflections is recorded in a separate table for each pendulum: (see Table A.14)			
Maximum heel angle achieved during the inclining, in degrees:			

(Continued)

Table D.7 (Continued)

Maximum deviation from running average, in per cent from Table A.14:		
Maximum deviation from final average, in per cent from Table A.14:		
Value of \bar{X}_T (the average value of X_Z) from Table A.14:	Pendulum 1:	Pendulum 2 (if used):
As inclined G_{FM_O} , in metres:	Pendulum 1:	Pendulum 2 (if used):
	Mean (where applicable):	
Is correction to G_{FM_O} required for variations in VCG between the vessel in the required loading condition and the vessel as inclined?		
Corrected $G_{FM_O} = G_{FM_O} + \frac{w_T \delta_H}{\Delta_M}$, in metres: (see Clause D8.3)		
Determination of maximum allowable heel angle		
Non-freeboard related limitations on maximum angle of heel, in degrees: (See NSCV Subsection 6A)	5 degrees if unsecured deck cargo or crane slew limited 10 degrees normally 14 degrees if measures to secure & prevent injury	
Allowable loss of freeboard / bilge emergence from stability criteria (See NSCV Subsection 6A), in metres:		
Least value of allowable angles for loss of freeboard, bilge emergence or non-freeboard related limitations, in degrees:		
Number of passengers:		
Number of crew:		
Number of persons in heeling moment calculation (N):	Passengers and crew if LM < 6 metres Passengers only for LM \geq 6 metres	
Person heeling mass (w) in kg:	80 for pax/persons 116 for divers	
Transverse centre of area of pax/persons (b), in metres:		
Persons heeling moment in tonne-metres:	$M_P = \frac{N w b}{1000}$	
Required minimum G_{FM_O} for persons heeling, in metres:		
Projected windage area above WL (AW) in m ² (see profile drawing):		
Distance from centre of projected area to centre of projected underwater profile (h), in metres:		

(Continued)

Table D.7 (Continued)

Wind pressure, in Pa:	Operational area C = 450 D = 360 E = 300
Wind moment, in tonne-metres:	$M_w = \frac{P_w A_w h}{1000 g} =$
Required minimum G_{FM_O} for wind heeling, in metres:	
Turning moment, in tonne-metres:	
Required minimum G_{FM_O} for turning, in metres:	
Lifting load (P_L), in tonnes:	
Distance from load point of attachment to centre-line of vessel (y), in metres:	
Moment due to lifting, in tonne-metres:	$M_L = P_L y =$
Required minimum G_{FM_O} for lifting, in metres:	
Maximum value of G_{FM_O} for persons heeling, wind heeling, turning and lifting:	
Comparison of maximum value of G_{FM_O} for persons heeling, wind heeling, turning and lifting against G_{FM_O} derived from the practical inclining experiment:	
Does this vessel carry passengers to sea?	
If previous question answered 'yes' then minimum required freeboard to deck, in mm:	150 if pax are all divers, otherwise 150 if $L_M < 6$ metres 250 if $L_M > 10$ metres $150 + \frac{(L_M - 6)}{4} \times 100$ if between =
Minimum freeboard to deck, in mm:	
Conclusions regarding stability:	
.....	
.....	
.....	
.....	

ANNEX E METHOD FOR CONDUCTING A STABILITY PROOF TEST

E1 SCOPE

This Annex describes the method for conducting a stability proof test.

It forms a normative part of this Subsection for the purposes of a deemed-to-satisfy solution.

E2 APPLICATION

This Annex shall apply to vessels required by Clause 4.4 to undergo a stability proof test.

E3 OBJECTIVE

The objective of this Annex is to specify a test for stability that allows a vessel to be assessed against specified criteria quickly and without unduly compromising accuracy.

E4 ACCURACY

The procedures and equipment used for the stability proof test shall be such as to facilitate measurements of sufficient accuracy to achieve adequately reliable results. Measures shall be taken to ensure that any uncertainties and/or errors, if and when they occur, are likely to underestimate the stability of the vessel.

E5 EQUIPMENT AND DATA

E5.1 Application

Requirements for equipment and data used in the stability proof test are specified in Table E.1.

Table E.1—Requirements for equipment and data

Requirement	Reference
The vessel	Clause A5.2
Reference data	Clause E5.3
Heeling masses	Clause E5.4
Means for measuring freeboards	Clause E5.5
Means for measuring angles of heel	Clause E5.6
Means for reading tank soundings or ullages	Clause E5.7

NOTE: Equipment additional to that specified above may facilitate meeting the requirements for accuracy specified in Clause E4; for example scales that could be used to determine the masses of equipment and personnel.

E5.2 The vessel

For each condition of loading specified for the stability proof test—

- a) the vessel shall be complete in respect of its lightship with all structure, machinery, outfit and equipment on board; and

NOTE: Refer to the definition of lightship in Subsection 6A for information on what constitutes the lightship.

- b) the contents of tanks, cargo and other masses present in the specified condition of loading shall either be present on board or simulated by known masses at the same locations of *VCG* and *LCG*.

E5.3 Reference data

A general arrangement drawing and tank calibration data shall be available for reference at the time of the stability proof test.

E5.4 Heeling masses

E5.4.1 Quantity

The total quantity of heeling masses provided for the stability proof test shall be sufficient to simulate the maximum heeling moment specified by the stability criteria with all the mass along one side of the vessel. The magnitude of each mass shall be verified by means of weighing on scales that have been certified or calibrated, or by minimum mass declaration on packaging.

NOTES:

1. The maximum heeling moment is determined using the general arrangement drawing to calculate wind, person and estimated turning moments.
2. Minimum mass declarations on packaging will on average underestimate the total mass, providing a conservative result.

E5.4.2 Arrangements for moving heeling masses

Suitable means shall be provided to safely and readily move the heeling masses from the centreline of the vessel to the side during the stability proof test.

E5.5 Means for measuring freeboards

Means shall be provided and/or methods used to facilitate the accurate reading of freeboards on both sides of the vessel without affecting the trim or angle of heel of the vessel.

NOTE: A small boat may be necessary to allow personnel to accurately read the freeboards during the stability proof test.

E5.6 Means for measuring angles of heel

Means shall be provided and/or methods used to facilitate the accurate measurement of heel angle.

NOTE: Heel angle may be determined from the change in freeboard measurements across the breadth of the vessel. Alternatively, a pendulum, calibrated inclinometer, digital inclinometer or a clear flexible tube containing coloured fluid and affixed to a transverse bulkhead in a U-configuration may be employed.

E5.7 Means for reading tank soundings or ullages

Means shall be provided to facilitate the accurate reading of tank soundings or ullages.

NOTES: Sounding tapes or sounding rods and sounding pipe information are normally required to allow accurate readings to be made.

E6 PREPARATION**E6.1 Application**

The preparatory steps specified in Table E.2 shall be satisfied prior to undertaking the stability proof test.

Table E.2—Requirements for preparation

Requirement	Reference
Control of the stability proof test	Clause E6.2
Limitations on persons on board	Clause E6.3
Berthing of the vessel	Clause E6.4
List	Clause E6.5
Removal of unnecessary items	Clause E6.6
Mass and distribution of persons on board	Clause E6.7
Positioning of heeling masses	Clause E6.8

E6.2 Control of the stability proof test

A competent person shall be nominated to be in charge of the stability proof test. The person in charge shall—

- a) have responsibility for providing equipment, making preparations, conducting the procedure, recording the data, and calculating the results; and
- b) have the authority to control the personnel carrying out the stability proof test.

NOTE: Normally the person in charge is a representative of the designer or builder of the vessel, or a consultant naval architect contracted for the purpose on behalf of the owner.

E6.3 Limitations on persons on board

Only crew or personnel that are participating directly in the stability proof test shall be on board the vessel during the conduct of the stability proof test.

NOTE: The results of a stability proof test will be invalidated if the magnitude and location of mass on the vessel (including persons and fluids) during the stability proof test is not strictly controlled.

E6.4 Berthing of the vessel

The vessel shall be berthed such that, during the stability proof test—

- a) the vessel will be in a protected position where it will be not be adversely affected by wind (particularly beam winds), tide, waves or currents.
- b) the depth of water at the berth is sufficient to ensure that the vessel does not ground at any time during the stability proof test.
- c) the vessel can float free from contact with the wharf or from hanging up on tight mooring lines.

E6.5 List

The initial list of the vessel shall not exceed 0.5 degrees from the vertical. Masses on board shall be distributed so as to plumb the vessel upright prior to commencement of the stability proof test.

E6.6 Removal of unnecessary items

Tools and tool boxes; welding equipment; staging; sand; debris and other temporary material on board, not forming a part of the lightship, shall be reduced to an absolute minimum before the stability proof test.

E6.7 Mass and distribution of persons on board

The mass and distribution of the persons on board the vessel shall be in accordance with the requirements of NSCV Part C Subsection 6A. Where masses are used instead of people they shall be raised to give the centre of gravity at the appropriate height, as specified in NSCV Part C Subsection 6A.

E6.8 Positioning of heeling masses

The heeling masses shall be accurately arranged along each side of the vessel at a height and longitudinal location consistent with the simulated condition of loading. The transverse distance between the two rows of masses shall be such that the product of the distance d between the rows and half the total heeling mass equates to the maximum required heeling moment, see Figure E.1.

NOTE: While other arrangements of heeling masses may be considered, that shown in Figure E.1 is the most efficient in terms of maximum angle of heel attained and the accuracy of measured lever.

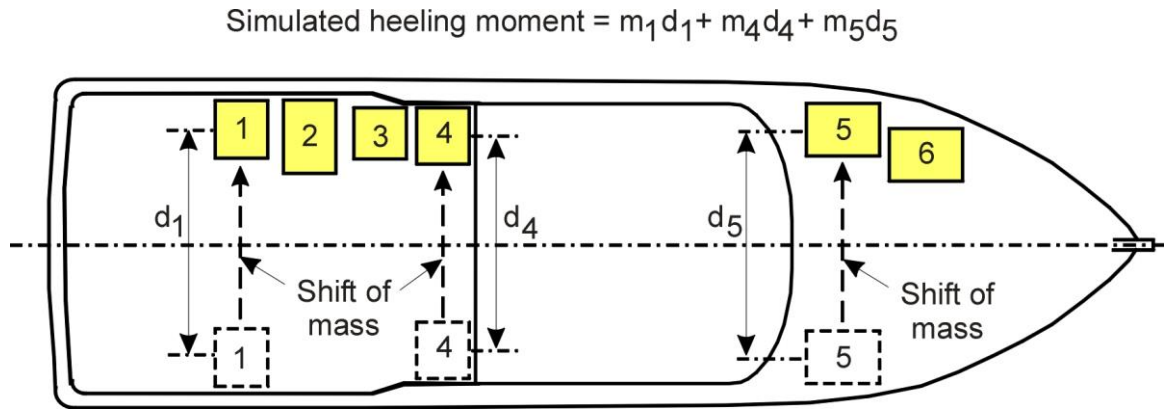

Figure E.1—Example of simulating the heeling moment during a stability proof test by means of heeling masses

E7 TESTING PROCEDURE

E7.1 Application

The testing procedure specified in Table E.3 shall be applied when undertaking the stability proof test.

Table E.3—Requirements for testing procedure

Requirement	Reference
Confirm suitability of environmental conditions	Clause E7.2
Confirm vessel in ready state	Clause E7.3
Freedom of vessel movement	Clause E7.4
Control of personnel	Clause E7.5
Recording of heeling masses	Clause E7.6
Confirmation of arrangements for determining the heel angle	Clause E7.7
Ascertaining and recording of liquids	Clause E7.8
Confirmation of the required loading condition	Clause E7.9
Recording of solid ballast	Clause E7.10
Measurement of freeboards	Clause E7.11
Initial angle of heel and freeboard readings	Clause E7.12
Movement of heeling masses, measurement of heel angle and freeboard with vessel heeled	Clause E7.13

E7.2 Confirm suitability of environmental conditions

The person in control of the stability proof test shall confirm that the environmental conditions are satisfactory for conduct of the test, taking into account the need for the vessel to be free to move and the effect of movement on the accuracy of readings taken during the course of the test.

The following factors shall be considered when deciding whether the test should be commenced or abandoned:

- a) The magnitude, direction and variability of any winds.
- b) The magnitude and direction of currents and tides.
- c) The rate of any precipitation and the ability of the decks to quickly and completely drain rainwater.
- d) The presence of any waves or frequent wake waves from passing craft.
- e) The magnitude of ripples on the water surface.

E7.3 Confirm vessel in ready state

The person in control shall confirm that the vessel is in a ready state for conduct of the stability proof test, taking into account the potential for error and the need for accuracy of readings taken during the course of the test. The following factors shall be confirmed prior to commencement of the stability proof test:

- a) Moveable masses, loose gear, shipyard plant and staging, have, where practicable, been removed from the vessel and those items that must remain on board have been secured against movement.
- b) Steps have been taken to remove all liquids in tanks that are not essential to the immediate needs of the vessel or the conduct of the stability proof test.
- c) The initial list of the vessel does not exceed 0.5 degrees from the vertical.
- d) On vessels having non-return closures in cockpit scuppers or on weather deck drains, such closures shall be restrained in the open condition during the test.
- e) All control valves for heeling and trimming tanks and cross-flooding connections have been securely closed.
- f) All pumps not required for essential services have been shut down.

E7.4 Freedom of vessel movement

The person in control shall ensure that the vessel is free to move during the stability proof test. Such steps shall include—

- a) removal and stowage of any gangway leading to shore during the stability proof test;
- b) verification that there will be sufficient depth of water over the period of the stability proof test to ensure the vessel continues to float free of the sea bed; and
- c) slackening of mooring lines to prevent contact with the wharf or hanging up as mooring lines tighten.

NOTE: Should occasional contact with the wharf still occur after slackening mooring lines, the vessel may be pulled free from the wharf and let drift during each measurement.

E7.5 Control of personnel

The person in control of the stability proof test shall ensure—

- a) all persons not engaged in the stability proof test have left the vessel;
- b) the person in charge of the engine room has been notified that the test is beginning, and that no fluid handling of any kind is to take place throughout the test; and
- c) all persons on board for the purpose of carrying out of the test understand their duties and the positions they must take up while the measurements are being read.

E7.6 Recording of heeling masses

The person in control of the stability proof test shall establish, confirm and record the mass, *VCG*, *LCG* and *TCG* of the individual heeling masses or mass groups.

NOTE: A diagram similar to that shown in Figure E.1 will assist in recording the essential particulars of heeling masses or mass groups.

E7.7 Confirmation of arrangements for determining the heel angle

The person in control of the stability proof test shall confirm that the arrangements to determine the heel angle are adequate and that the readings can be taken without altering the heel and/or trim of the vessel.

E7.8 Ascertaining and recording of liquids

The person in control of the stability proof test shall inspect the vessel to ascertain the state of all tanks and spaces on the vessel that may contain liquids. The inspection shall confirm whether all bilges, void spaces and tanks that are designated as empty are in fact dry by either visual inspection or, where visual inspection is not practicable, by soundings.

NOTES: A typical table template for recording the contents of tanks is given in Table A.13.

E7.9 Confirmation of the required loading condition

The person in control of the stability proof test shall inspect the vessel to confirm that the vessel as tested is properly representative of the required condition of loading. Masses that are yet to be fitted may be simulated, and masses to be removed may be used for simulation.

E7.10 Recording of solid ballast

On vessels where permanent solid ballast is fitted, the masses and centres of gravity of the ballast in each stowage position shall be recorded.

NOTE: Calculation of the lightship condition includes any permanent solid ballast fixed in position. The recording of solid ballast on board during the stability proof test is important for future reference.

E7.11 Measurement of freeboards

Freeboards shall be measured as follows:

- a) For decked or well deck vessels, from either—
 - i) the lowest point of the deck; or
 - ii) the deck at $0.75 L_M$ from bow if the least freeboard is aft of $0.75 L_M$, in metres.
- b) For a cockpit or open boat, the lowest point of gunwale.

E7.12 Initial angle of heel and freeboard readings

All personnel involved in the stability proof test shall take up their designated positions for the initial readings. Freeboards shall be measured port and starboard to confirm that the vessel is upright, see Annex L. The minimum freeboard readings of the vessel in the upright condition shall be recorded for use in assessing criteria.

E7.13 Movement of heeling masses, measurement of heel angle and freeboard with vessel heeled

Once the initial measurements have been taken, the heeling masses are progressively transferred from one side of the vessel to the other, watching for any signs of excessive heel that could result in sudden capsizes. Once the heeling masses have been moved, the following steps shall be undertaken:

- a) Confirm and record the distance d the heeling mass has been moved, in metres.
- b) If the vessel's lifting gear is being used, securely re-stow the lifting gear.
- c) If shore gear is being used, uncouple the lifting hook.
- d) Recall the persons on board to their positions during the taking of readings.
- e) Make certain that all moorings are slack and that the vessel is clear of the berth.
- f) Allow time for the vessel to steady.
- g) Measure freeboards at the same locations as the initial readings, see Annex L.
- h) Determine and record the heel angle, refer note to Clause E5.6 for methods.

E8 CALCULATIONS, RESULTS AND REPORT**E8.1 Stability compliance report**

The stability proof test shall be recorded in a report. The report shall contain the relevant calculations to enable the vessel's stability to be

compared against the relevant minimum stability criteria. The report shall contain all information necessary to allow independent review of the results.

NOTE: A typical format for a stability proof test report is given in Table E.4.

Table E.4—Stability compliance report for a Stability Proof Test

Name of vessel:			Date:
Place of Stability Proof Test:			
Principal dimensions:	L_M		B
Vessel type:	Flush deck	Well deck	
	Cockpit deck	Open	
Owner of vessel:			
Builder of vessel:			
Proof test conducted by:			
Independent person:			
State of weather:			
Mooring arrangements:			
Loading condition to be simulated:			
State of bilges:			
State of equipment:			
State of fuel tanks:			
State of FW tanks:			
State of sullage tanks:			
State of other tanks:			
State of cross connections:			
Mass & location of permanent ballast:			
Number of passengers:			
Number of crew:			
Number of persons in heeling moment calculation (N):	Passengers and crew if $L_M < 6$ metres Passengers only if $L_M \geq 6$ metres		
Person heeling mass (w) in kg:	80 for pax/persons 116 for divers		
Transverse centre of area of pax/persons (b), in metres:			
Passenger heeling moment in tonne-metres:	$M_P = \frac{N w b}{1000}$		
Projected windage area above WL (A_w) in m ² (see profile drawing):			
Distance from centre of projected area to centre of projected underwater profile (h), in metres:			

(Continued)

Table E.4 (Continued)

Wind pressure, in Pa:	Operational area C = 450 D = 360 E = 300
Wind moment, in tonne-metres:	$M_W = \frac{P_W A_W h}{1000 g} =$
Lifting load (P_L), in tonnes:	
Distance from load point of attachment to centre-line of vessel (y), in metres:	
Moment due to lifting, in tonne-metres:	$M_L = P_L y =$
Moment applied to vessel (maximum of M_P , M_W or M_L , in tonne-metres:	
Lever heeling masses moved, in metres:	
Mass required for proof test, in tonnes:	$\frac{moment}{lever} =$
Required mass simulated by:	Masses: Persons:
Distribution of required mass on vessel:	
Non-freeboard related limitations on maximum angle of heel, in degrees: (See Subsection 6A)	5 degrees if unsecured deck cargo or crane slew limited 10 degrees normally 14 degrees if measures to secure & prevent injury.
Method used to measure heel angles:	
If pendulum used— Pendulum (l) length, in metres:	
Deflection of pendulum (a), in metres:	
Angle of heel, in degrees:	In case of where pendulum used— $Tan^{-1}\left(\frac{a}{l}\right) =$
Freeboard at lowest point or for decked vessels or well deck vessels 0.75 L_M from bow if least freeboard is aft of 0.75 L_M , in metres	
Freeboard upright, in metres:	
Freeboard heeled, in metres:	
Loss of freeboard not to exceed:	

(Continued)

Table E.4 (Continued)

For decked vessels:	$\frac{f_U}{2}$	where f_U = upright freeboard, in metres L_M = measured length, in metres C = cockpit length, in metres
For well deck vessels:	$\frac{f_U}{2}$	
For open vessels:	$\frac{f_U}{4}$	
For cockpit vessels in operational area C:	$\frac{f_U(2L_M - 1.5C)}{4L_M}$	
For cockpit vessels in operational areas D or E:	$\frac{f_U(2L_M - C)}{4L_M}$	
Does this vessel carry passengers to sea?		
If the answer to the above question is 'yes' then minimum freeboard to deck required, in mm:	150 if pax are all divers, otherwise 150 if $L_M < 6$ metres 250 if $L_M > 10$ metres $150 + \frac{(L_m - 6)}{4} \times 100$ if between =	
Minimum freeboard to deck, in mm:		

Conclusions regarding stability:

ANNEX F SPECIFICATION FOR THE FORM AND CONTENT OF A STABILITY BOOK

F1 SCOPE

This Annex describes the deemed-to-satisfy specification for the form and content of a stability book. It forms a normative part of this Subsection.

F2 APPLICATION

This Annex shall apply to vessels required by Chapter 5 to have a stability book.

F3 OBJECTIVE

The objective of this Annex is to specify the information for competent persons responsible for safety to readily assess and control for safety purposes the intact stability of the vessel.

F4 FORMAT OF A STABILITY BOOK

The stability book shall serve the functions of stability compliance report and the *operator's* stability manual. The stability book shall be in a form suited for ready use by the *operator* and other persons responsible for controlling the intact stability of the vessel. This shall be a paper copy having a durable cover and secure binding.

NOTES:

1. Stability information in an electronic format may be used in addition to the paper copy provided the software and hardware on the vessel comply with IMO Guidance Circular MSC/Circ.891 Guidelines for the on-board use and application of computers.
2. Electronic forms may also need to be in a form suited for review by the National Regulator.

F5 CONTENT OF A STABILITY BOOK

The stability book shall contain the contents specified in Table F.1.

Table F.1—Contents of a stability book

Item	Details	Comments
Title page	Stability book title, name of vessel, classes of service, and the date of preparation or latest amendment shown.	
Contents page	Contents, each referenced by page numbers	All pages to be consecutively numbered
Particulars of the vessel and datums for measurements	General particulars Drawing of vessel Draft mark diagram Load line diagram	See Clause F6

(Continued)

Table F.1 (Continued)

Item	Details	Comments
Applicable stability criteria	Refer to NSCV Part C Subsection 6A	Specify the allowable angle(s) of heel for single/combined heeling moments as applicable, see Subsection 6A.
Immersion angle information	Angles of deck edge immersion, downflooding and potential downflooding;	See Clause F7
Guidance for the operator	<ul style="list-style-type: none"> - Purpose - Limiting conditions - Warnings - Explanations to the stability book - Operation of the vessel 	See Clause F8
Heeling moments	Data to allow calculation of heeling moments including person, wind, turning and those from special operations. Refer to NSCV Part C Subsection 6A	To either take into account changes in heeling moment that occur as displacement varies or a value representing the maximum heeling lever that can arise at any displacement.
Loading conditions	Lightship conditions, worst case loading conditions, loading conditions for special operations	See Clause F9
Worked example of loading condition	Instructions on how to carry out a stability assessment by working through an entire loading condition including determination of free surface correction.	The worked example shall be limited to use of abbreviated stability calculation methods where such methods are required in Clause 5.4.6.2
Tank information	<ul style="list-style-type: none"> - Tank layout diagram - Tank summary table - Tank calibration data 	See Clause F10 Tank calibrations not required for tanks kept full in service.
Cargo and stores information	<ul style="list-style-type: none"> - Dry cargo space and store space diagram - Dry cargo and store space summary table - Cargo space calibration data - Deadweight scales 	See Clause F11 The requirement for deadweight scales is limited to Class 1 or Class 2 vessels over 24 m in length that load cargoes.
Hydrostatic and <i>KN</i> data	<ul style="list-style-type: none"> - Hydrostatic data - <i>KN</i> data 	See Clause F12
Lightship particulars	Report of the inclining experiment or lightship measurement including the calculations used to determine the lightship condition characteristics	See Clause A8.8

F6 VESSEL PARTICULARS AND MEASUREMENT DATUMS**F6.1 General particulars**

The following particulars of the vessel shall be listed in the stability book:

- a) The vessel's name.
- b) The vessel's identification number (official number, registration number, etc).
- c) The vessel's port of registration, if any.
- d) The vessel's measured length (L_M).
NOTE: Refer to NSCV Part B to determine measured length.
- e) The length for hydrostatics (L_H).
- f) The vessel's breadth (B).
- g) The vessel's moulded depth (D).
- h) The vessel's maximum permissible draft corresponding to the least value of the draft to the—
 - i) subdivision load line;
 - ii) geometric load line;
 - iii) maximum design structural displacement; and
 - iv) maximum displacement for compliance with intact stability criteria.
- i) The position of the longitudinal measurement datum for use in the stability book calculations relative to the nearest frame or other relevant fixed structural reference point. See Clause F6.2.

NOTE: The longitudinal datum amidships has been assumed for the purposes of this Standard. The amidships datum can have an advantage if it provides an intuitive indication of the effect on trim that is likely to result by the removal or addition of items by referencing them forward or aft of amidships; i.e., when the LCF is close to amidships.

- j) The position of the baseline for use in the stability book calculations, see Clause F6.2.
- k) The service categories for which the stability has been assessed and the maximum persons permitted on the vessel for each service category.

NOTE: The various vessel use and operational area categories are specified in NSCV Part B.

F6.2 Measurement datums

The measurement datums specified in Table F.2 shall be used for the presentation of all stability data and calculations presented in the stability book.

Table F.2—Standard measurement datums

Dimension	Measurement datum	Sign convention
Vertical measurements	The baseline of the vessel located— 1. at the underside of keel on a vessel without rise of keel or rocker, or 2. at the lowest part of keel parallel to the design waterline on a vessel with a rise of keel or with rocker in the keel.	+ve upwards
Longitudinal measurements	A point either at amidships of the design waterline or at the aft end of the design waterline.	+ve forward
Transverse measurements	The longitudinal centre line of the vessel.	+ve port

F6.3 Drawing of vessel

The stability book shall include a profile view and, if required for clarity, plan views of the vessel drawn to scale. The drawing shall show the following:

- a) All compartments, tanks, storerooms and crew and passenger accommodation spaces with their names.
- b) The location of amidships.
- c) The baseline.
- d) Except on vessels not having a regular frame spacing, the frame spacing over the length of the vessel.
- e) The positions of forward and aft perpendiculars and amidships marked relative to the nearest frames or other relevant fixed structural reference point.
- f) For vessels with a designed rake of keel, all dimensions that relate the line of the underside of the keel to the baseline including the location of the forward draft datum.

F6.4 Draft mark information

On vessels that are required to have draft marks, a drawing to scale shall be included that shows the arrangement of draft marks forward and aft, their spacing and location relative to the perpendiculars. This diagram may be combined with the load line diagram.

F6.5 Load line diagram

A diagram drawn to scale shall be included showing the load line mark and load lines with particulars of the corresponding freeboards, and also showing the displacement, tonnes per centimetre immersion, and deadweight mass corresponding in each case to a range of mean drafts extending between the waterline representing the deepest load line and the waterline of the vessel in lightship condition.

F7 IMMERSION ANGLE INFORMATION

The stability book shall contain a diagram with or without tables that:

- a) clearly identify the points of—
 - i) potential downflooding θ_p ;
 - ii) downflooding θ_f ; and
 - iii) for sailing vessels, deck edge immersion θ_d .
- b) provides sufficient information to enable the angles of potential downflooding and flooding to be determined.

NOTE: Similar information for determining the angle of deck edge immersion can also be of value when assessing stability.

F8 GUIDANCE TO THE OPERATOR

F8.1 Requirement

The stability book shall contain guidance information to the *operator* for the proper loading of the vessel and for the control of stability in accordance with Clause F8.2.

F8.2 Content

F8.2.1 Purpose

The guidance information shall specify the purpose of the stability book.

NOTE: The purpose may include the calculation of loading conditions to verify stability during operation, the presentation of stability for third party verification, etc.

F8.2.2 Limiting conditions

The guidance information shall describe the specific vessel characteristics that limit the loading of the vessel.

NOTE: Such limitations might include the maximum number and distribution of passengers on decks, minimum freeboard for load line, subdivision criteria, intact stability characteristics, particular operational heeling moments, scantling draft, and longitudinal bending.

F8.2.3 Explanations to the stability book

The guidance information shall contain such explanations that are necessary to facilitate proper use of the stability book in accordance with the stated purpose.

NOTE: Such explanations might include signs of trim, applicability of hydrostatic data with regard to trim, applicability of stability limits with regard to trim, height of deck cargo or other parameters; and general advice on the use of tables or diagrams with regard to accuracy and interpolation.

F8.2.4 Operation of the vessel

The guidance information shall outline aspects of the stability that are relevant to the safe operation of the vessel. The guidance shall include, but not necessarily be limited to the following:

- a) The guidance information shall warn of any potentially dangerous conditions that might be met in practice.

NOTE: Such warnings might include the need for the *operator* to exercise prudence and good seamanship, having regard to the season of the year, weather forecasts and the operational area, and to take the appropriate action as to speed and course warranted by the prevailing conditions.

- b) Measures required to maintain the weathertight and watertight integrity of the vessel in accordance with the assumptions used to prepare the stability documentation.
- c) Where the buoyancy of a superstructure for a ro-ro vessel or similar vessel having bow doors, side doors, or stern doors, is included in the stability calculation, the guidance information shall contain specific statement that such doors must be secured watertight before the vessel proceeds to sea.

- d) The characteristics of the lightship condition with regard to stability, trim, any heeling moment due to asymmetrical equipment, any permanent ballast and, where applicable, longitudinal stress parameters.
- e) Limitations, if any, on the use and distribution of consumables at different stages of consumption and its effect on centre of gravity above keel (*VCG*) in the loaded condition.
- f) The need, if any, to take on ballast to compensate for an increase in the centre of gravity above keel (*VCG*) due to fuel consumption during the voyage.
- g) The measures, if any, needed to identify and control potentially excessive bending moments and shear forces resulting from different loading conditions.
- h) Information on the potential effects and correct use of specific equipment on the vessel that could, if misused, have an adverse effect on stability.

NOTE: Such equipment might include towing equipment, cranes, trawl equipment, anti-rolling devices, counter ballasting or counter masses, sails, wet fish holds, snagging winches, etc.

- i) Operating limits, if any, with regard to loading and distribution of cargo and ballasting.
- j) A general warning on the potentially dangerous effects of free surface in tanks and bilges with an instruction to keep bilges dry and tanks that are not in use either completely empty or completely filled up, especially in circumstances where the stability is marginal.
- k) A general warning against operating the vessel with a steady angle of heel because of the reduction of stability. The need to keep the vessel upright at all times by a symmetrical distribution of masses.
- l) A general warning that physical modifications to a vessel may reduce stability and that, before these are made, the stability must be rechecked and the stability book updated to reflect any changes in the stability of the vessel, see note in Clause 5.4.4.

F8.2.5 Cargo

If cargo is to be carried, the guidance material shall specify any requirements as to the allowable quantity, distribution and securing of the cargo.

F8.2.6 Water ballast

The guidance material shall specify if in any loading condition water ballast is necessary and if so, the quantity and disposition shall be stated.

F8.2.7 Anti-rolling devices

Where anti-rolling devices are installed in a vessel that could impact on the stability of the vessel, information relevant to their proper use shall be provided within the stability book.

F8.2.8 Vessels engaged in towing

A warning shall be provided highlighting the dangers of the vessel girting. Guidance shall be provided on the measures required to avoid girting, the use of the tow-rope quick release mechanism and the need to load the tow-rope gradually.

NOTE: Girting is the capsizing effect that arises when the pulling force through the tow-rope acts at a large angle to the longitudinal axis of the tug.

F8.2.9 Vessels that set sail

For vessels that set sail, guidance information shall be provided that includes—

- a) a statement specifying the *operator's* responsibility for reducing sail to suit the weather conditions;
- b) a sail plan of the vessel with the various sails identified;
- c) a polar diagram or similar data providing guidance as to the combination of sails to be set for a given average wind strength and wind heading;

NOTE: The speed of wind gusts can be up to twice the average wind speed.

- d) a list of any openings on deck identified as critical to stability when under sail; and
- e) the value and explanation of the recommended steady heel angle.

NOTE: Such information could include a graphical presentation of the maximum steady angle to prevent downflooding in gusts and squalls.

F8.2.10 Lifting operations**F.8.2.10.1 General**

On vessels that engage in lifting masses by crane, derrick, winch or other means, the guidance shall include information as to correct usage of such equipment including loading limitations and heel criteria.

F.8.2.10.2 Table of draft versus maximum vertical moment

Where a vessel has no counter ballast capability, a table showing draft versus maximum vertical moment of deck cargo and hook load combined shall be included in the stability book. Such tables shall be provided for the hook load over the beam; and such other orientations of the hook load as necessary to control the safe operation of the crane.

NOTE: This table is obtained by drawing righting lever (G_{FZ}) curves for various values of the centre of gravity above keel (VCG) values until the maximum centre of gravity above keel (VCG) that satisfies the criteria is obtained. This centre of gravity above keel (VCG) is then converted into a maximum vertical moment by subtracting the vertical moment due to the mass of the barge in lightship condition.

F.8.2.10.3 Counterweights

With a permanent counterweight, the counter-heeling lever is defined at each displacement. The heeling lever is a variable depending on the

maximum hook load capacity at each radius. The table may be made up only for the maximum heeling moment or for a range of moments. (Generally three radii will be found sufficient).

F.8.2.10.4 Counter ballasting

Where counter ballasting is employed, instructions shall be included specifying the amounts of ballast required for various heeling moments, together with the corresponding free surface effects. The guidance material shall include advice as to any time factors required for altering ballast as the load is moved.

NOTES:

1. There are four key parameters that need to be considered: draft, maximum vertical moment; jib or derrick radius; and counter ballast configuration.
2. If three radii are used, the number of tables to be provided is three times the number of counter ballasting configurations.

F9 LOADING CONDITIONS

F9.1 Loading conditions to be representative of operations

The loading conditions presented in the stability book shall be representative of the range of operating conditions having regard to the nature of the vessel and its intended operations.

F9.2 Worst case loading conditions

The loading conditions presented shall include any having marginal stability characteristics relative to the relevant stability criteria.

NOTE: The stability book should be prepared in consultation with the *operator* to ensure that the loading conditions are representative of the vessel's intended operation and that the worst case scenarios have been identified and analysed. For vessels that engage in trawling, refer to the declaration by the owner mentioned in Subsection 6A.

F9.3 Standard loading conditions

F9.3.1 Departure and arrival conditions

Loading conditions calculated to be representative of departure or arrival conditions shall comply with the requirements specified in Table F.3.

Table F.3—Standard departure and arrival conditions

Loading condition	Requirement
Departure condition	Departure with full consumables, including full stores and all fuel and freshwater tanks full. Free surface shall be assumed present in at least one main fuel tank and one freshwater tank, in each case using the maximum free surface value. Sullage tanks shall be considered empty with maximum free surface.
Arrival condition	Arrival with consumables including fuel, fresh water, consumable stores all reduced to 10 per cent of their capacity. Free surface shall be assumed present in all tanks that are not completely filled or completely empty, in each case using the maximum free surface value. Sullage tanks shall be considered full with free surface.

F9.3.2 Vessel specific loading conditions

Subject to Clauses F9.1 and F9.2, the minimum requirement for loading conditions within the stability book for vessels of various types and operation shall be as specified in Table F.4.

NOTE: A vessel may be required to apply more than one of these loading conditions concurrently in which case the requirements are superimposed.

EXAMPLE:

A crane barge lifting in near laden and ballasted conditions would apply the requirements for lifting loading conditions to those specified for cargo vessels.

Table F.4—Minimum loading conditions for various vessel types and operation

Application	Loading condition	Details
All vessels	Lightship condition	No cargo, consumables, stores or non-permanent ballast
Vessels carrying passengers	Maximum passengers (D & A)	Passengers distributed to result in the worst <i>VCG</i>
	Maximum heeling moment (D & A)	Passengers distributed to result in the largest heeling moment with least favourable <i>VCG</i>
Vessels carrying cargo	Homogeneous fully laden conditions (D & A)	Vessel laden to the lesser of the load line draft or the maximum scantling draft with a homogenous cargo that fully fills the hold space, see Key (1), (2)
	Fully laden deck cargo conditions (D & A)	For vessels that load deck cargoes, the vessel laden to the lesser of the load line draft or the maximum scantling draft with a cargo that includes the deck cargo, see Clause F9.3.3
	Ballasted conditions (D & A)	Vessel without cargo and with minimum specified quantity of ballast
Vessels engaged in lifting masses	Maximum capacity of lifting device (D & A)	Vessel engaged in lifting the heaviest rated load of the lifting device at maximum elevation and greatest corresponding heeling moment
	Maximum heeling moment of lifting device (D & A)	Vessel engaged in lifting the maximum combination of mass and outreach with the greatest corresponding <i>VCG</i>
Fishing vessels	No catch condition (D & A)	With fuel, stores and pre-made ice as consumables and fishing gear
	Fully laden with catch condition (A)	Arrival condition only (departure condition from fishing grounds is already analysed as last shot, see below)
	Twenty per cent catch condition (A)	Arrival condition only (departure condition from fishing grounds is already analysed as last shot, see below)

(Continued)

Table F.4 (Continued)

	Worst foreseeable fishing conditions	This shall take into account the following as appropriate to the particular vessel and type of fishing— <ul style="list-style-type: none"> - lifting the cod end on board, - ice manufactured on board the vessel, - the mass and potential free surface of fish on deck or in sorting trays, - the mass of water and free surface in brine tanks, wet holds, and/or bait tanks, - the snagging of a fishing net while deployed; and the subsequent attempts to retrieve the snagged net, - the likely potential variations in consumables. Consumables at the fishing grounds shall be assumed to vary between 80% and 20%, - the likely potential variations in load carried within the fish holds or tanks. Catch in holds shall be assumed to vary from empty to 'full but for the last shot'
Vessels engaged in towing	Towing conditions (D, A & I)	Arrival, departure and at least one intermediate condition
Offshore supply vessels	Fully laden conditions, maximum deck cargo (D & A)	Maximum deck cargo and with balance of cargo distributed below deck
	Fully laden conditions—cargo tanks full (D & A)	Maximum liquid cargo distributed below deck and with balance of cargo specified by position and mass on deck
	Fully laden condition—cargo tanks empty (D & A)	Maximum solid cargo distributed below deck and with balance of cargo specified by position and mass on deck
	Fully laden condition—pipe cargo (D & A)	Maximum pipe cargo and with balance of cargo distributed below deck, see Clause F.9.3.3.3
	Worst case condition (D & A)	Worst case loading if not already covered by one of the fully laden conditions above
	Ballasted (D & A)	Illustrate minimum requirements for ballasting
	Special operations (D & A)	Towing, anchor handling and/or other special operations
Vessels that set sail	Sailing conditions (D & A)	Loading conditions as per the requirements for the specific type of operation but with additional analysis against the applicable sailing criteria from Subsection 6A
	Additional light load condition for sailing catamarans (D & A)	Arrival condition with no passengers or cargo on board

(Continued)

Table F.4 (Continued)

Application	Loading condition	Details
Hopper vessels, see Clause F9.3.4	Lightship condition	Calculated assuming water is in the hold space
	Ballasted (D & A)	Calculated assuming water is in the hold space
	Intermediate stages of loading (D & A)	Calculated assuming one third of the maximum deadweight mass of dredgings and water is in the hold space
	Fully laden—Maximum density cargo (D & A)	Dredgings of the anticipated maximum density
	Fully laden—Minimum density cargo (D & A)	Dredgings of the anticipated minimum density
	Failure of one bottom door (D & A)	In a vessel fitted with pairs of bottom doors or other similar means of jettisoning cargo, a condition to indicate the heeling effect should the doors on one side fail to open when the vessel is in its worst case stability condition

KEY:

(D) Departure condition (see Clause F9.3)

(A) Arrival condition (see Clause F9.3)

(I) Intermediate consumables condition (50% approx)

(1) Cargo for this purpose is taken to be homogenous except where this is clearly inappropriate, for example where there are cargo spaces in a vessel which are intended to be used exclusively for the carriage of vehicles or cargo on pallets.

(2) If the stability characteristics in either of the laden with homogeneous cargo conditions do not satisfy the minimum criteria, such conditions shall be marked accordingly and an appropriate warning to the *operator* shall be inserted in the stability book.

F9.3.3 Deck cargo**F.9.3.3.1 Maximum height**

The maximum height of the deck cargo and its assumed centre of gravity shall be clearly stated.

F.9.3.3.2 Timber deck and other absorbent deck cargo

Where the deck cargo is a type that may absorb water the estimated mass of the deck cargo shall be modified for the arrival condition to include an allowance for the mass of water likely to be absorbed during the voyage. In the case of timber deck cargo the estimated mass of the absorbed water shall be taken as 15 per cent of the mass of the timber deck cargo.

Where water may be entrained within a deck cargo, an estimate of the mass of the entrained water shall be included in the loading condition, see also Clause F.9.3.3.3.

F.9.3.3.3 Pipe cargoes

Where pipes are carried on deck, a quantity of trapped water equal to a specified percentage of the net volume of the pipe deck cargo shall be assumed in and around the pipes. The net volume shall be taken as the internal volume of the pipes plus the volume between the pipes multiplied by the factor specified in Table F.5.

Table F.5—Factor for pipe cargo entrapped water

Freeboard amidships F_B	Factor
$\leq 0.015 L_M$	30 per cent
Between $0.015 L_M$ and $0.03 L_M$	$30 - 20 \left(\frac{F_B/L_M - 0.015}{0.015} \right)$
$\geq 0.03 L_M$	10 per cent

KEY:

L_M is the vessel's measured length, in metres.

F_B is the vessel's freeboard amidships, in metres.

F9.3.4 Hopper vessels

Loading conditions for hopper vessels that have open holds that contain water and dredgings shall take into account the spillage of saturated dredgings and water that occurs as the vessel heels. The values of G_{FZ} shall either be determined by computer simulation or estimated using the the spillout method.

NOTE: A description of the spillout method is contained in USL Code Section 8C Clause C6.

F9.4 Minimum standard format

The measurement datums used for all loading condition calculations shall be the location of amidships and the baseline specified in Clause F6.

Each loading condition presented in the stability book shall contain the following information:

- a) A loading condition table that lists—
 - i) the lightship particulars;
 - ii) the disposition and the total mass of all components of the deadweight; their VCG , LCG , vertical and longitudinal moments and free surface moments where applicable; and

- iii) the calculated total displacement of the vessel in the loading condition, the corresponding vertical and longitudinal locations of the centre of gravity and total free surface moment.
- b) A calculation of the trim and corresponding drafts at forward and aft draft marks.
- c) A calculation of the correction to the total *VCG* for the total free surface moment.
- d) A calculation of the metacentric height (G_{FM0}).
- e) A calculation of the righting lever (G_{FZ}) curve derived from the *KN* data referred to in Clause F12 shall be drawn over its full positive range, or up to the angle of flooding.
- f) A diagram showing the righting lever (G_{FZ}) curve from e).
- g) Where credit is shown for the buoyancy of a timber deck cargo, the righting lever (G_{FZ}) curve must be drawn both with and without this credit.
- h) The following shall be shown on each righting lever (G_{FZ}) curve:
 - i) The potential angle of flooding θ_p .
 - ii) The actual angle of flooding θ_f .
 - iii) The angle of deck edge immersion θ_d (for loading conditions of a vessel when under sail).
- i) Where specified by the criteria in Part C Subsection 6A, one or more heeling lever curves shall be superimposed over the righting lever curve.
- j) A statement comparing the actual values of stability parameters determined from the particular loading condition against those required by the relevant stability criteria.

NOTES:

1. Provision of a profile diagram of the vessel drawn to a suitable scale showing the disposition of all components of the deadweight for each loading condition can greatly assist users, particularly for the more complex types of vessels.
2. Adopting the same scale of the righting lever curve (G_{FZ} curve) for all loading conditions allows a ready comparison of relative stability characteristics.

F10 TANK INFORMATION

The measurement datums used for tank information shall be the location of amidships and the baseline specified in Clause F6.

The stability book shall contain the following tank information:

- a) A plan and/or profile view of the vessel showing the name and location of all tanks.
- b) A tank summary table listing the name of each tank, its contents, capacity when full, percentage of capacity when assumed full (see note), assumed specific gravity, the vertical centre of gravity of the

tank when full, the longitudinal centre of gravity of the tank when full and the maximum free surface moment.

NOTE: Normal practice for tanks that contain oil is for such tanks to be filled to not more than 98% of the total capacity. The remaining 2% of volume provides a margin for any expansion of the contents that may occur due to changes in ambient temperature.

- c) Tank calibrations listing the capacity, vertical centre of gravity, longitudinal centre of gravity and longitudinal location of the sounding pipe for each sounding reading at intervals of not more than 50 mm. Tank calibrations are required for every tank having a capacity when filled equal to or more than the lesser of—
 - i) 10 per cent of the vessel's lightship displacement; or
 - ii) 2 tonnes.

F11 CARGO AND STORES INFORMATION

The measurement datums used for cargo and stores information shall be the location of amidships and the baseline specified in Clause F6.

The stability book shall contain the following cargo and stores information:

- a) A diagram showing the name and location of all cargo and stores spaces.
- b) A cargo and stores summary table listing the capacity and the centre of gravity (longitudinally and vertically) for every compartment available for the carriage of cargo or stores not already accounted for in the requirements for tank information in Clause F10. In the case of a ro-ro vessel, the vertical centre of gravity of compartments for the carriage of vehicles shall be based on the estimated centres of gravity of the vehicles and not on the volumetric centres of the compartments.
- c) Cargo space calibrations listing the capacity, vertical centre of gravity and longitudinal centre of gravity for each ullage reading at intervals of not more than 50 mm.

F12 HYDROSTATIC AND *KN* DATA

F12.1 Extent of data required

The stability book shall contain sufficient hydrostatic and *KN* data to enable the user to calculate and/or verify the stability of the vessel against the applicable stability criteria specified in Part C Subsection 6A for all anticipated loading conditions.

F12.2 Range of drafts / displacements

The hydrostatic and *KN* data shall be for a range of mean drafts / displacements extending not less than from a waterline above the draft corresponding to the fully laden condition to a waterline below the draft corresponding to the vessel in the lightship condition. Data for additional drafts / displacements above the fully laden condition shall be provided for

vessels that are subject to criteria that analyse loading potentially above the normal operating fully laden displacement.

EXAMPLES:

Water entrapped in a deck cargo

A snagged net

The retrieval of a snagged net

Where a tabular format is used, the interval between drafts / displacements listed in the table shall be at regular equi-spaced intervals that are sufficiently close to permit accurate interpolation.

NOTE: Recommended maximum values for the spacing of tabular hydrostatic values are given in the following table:

Fully laden draft T (m)	Recommended maximum spacing (mm)
< 0.5	10 mm
0.5 to 1.5	20 mm
1.5 to 5.0	50 mm
> 5.0	100 mm

F12.3 Range of trim

Hydrostatic and KN data shall be determined at a trim representative of the range of normal operating conditions, typically *level trim*. Where the maximum difference between the trim over the range of normal operating conditions and the trim used for the hydrostatic and KN data exceeds the value specified in Clause A8.3.3 increased by 30 per cent, then additional hydrostatic and KN data shall be included in the stability book. The additional data shall be calculated at one or more trims chosen to satisfy the maximum allowable trim difference criterion for all conditions of loading.

F12.4 Hydrostatic particulars

The hydrostatic data shall include the hydrostatic particulars shown in Table F.6. The measurement datums used for the hydrostatic data shall be the longitudinal datum and the baseline specified in Clause F6.

Table F.6—Hydrostatic particulars

Symbol	Definition of hydrostatic particular	Application
Draft (T)	The vessel's draft at amidships measured to the baseline, in metres	All vessels
Δ	The vessel's displacement in seawater, in tonnes	Note 1
Δ_F	The vessel's displacement in fresh water, in tonnes	Note 2
LCB	The longitudinal centre of buoyancy from the longitudinal datum, in metres	All vessels
VCB	The vertical centre of buoyancy from the baseline, in metres	All vessels
LCF	The longitudinal centre of flotation from the longitudinal datum, in metres	All vessels
MCT	The moment to change trim one centimetre, in tonne-metres	Note 1
MCT_F	The moment to change trim one centimetre in fresh water, in tonne-metres	Note 2
TPC	The tonnes per centimetre immersion, in tonnes	Note 1
TPC_F	The tonnes per centimetre immersion in fresh water, in tonnes	Note 2
KM_T	The transverse metacentre above the keel, in metres	All vessels
C_B	The block coefficient measured to the appropriate draft	Note 3

NOTES:

1. Δ , MCT and TPC may be omitted in the hydrostatic particulars of vessels that are intended to operate exclusively in fresh water.
2. Δ_F , MCT_F and TPC_F may be omitted in the hydrostatic particulars of vessels that are intended to operate exclusively in salt water.
3. C_B is only required for vessels where compliance with the severe wind and rolling criteria as specified in Part C Subsection 6A is required.

F12.5 Angles of heel for calculation of KN data

The KN data shall be calculated by the free trimming method, at intervals of not more than 10 degrees for a range of heel angles not less than that specified in Table F.7.

Table F.7—Minimum range of heel angles for calculation of KN data

Type of vessel	Minimum range of heel angle (degrees)
Vessels that set sail and apply Chapter 6A criteria	0 to 90 if seagoing 0 to 70 if sheltered waters
Vessels that set sail and apply Chapter 6B criteria	0 to 110
All other vessels	0 to 60

ANNEX G PREPARATION OF KN DATA AND TERMINATION OF RIGHTING LEVER CURVES (G_{FZ} CURVES)

G1 SCOPE

This Annex describes the deemed-to-satisfy specification for the preparation of KN data and termination of righting lever curves (G_{FZ} curves) intended for use in calculations used to verify a vessel's stability characteristics against the criteria contained in NSCV Subsection 6A.

It forms a normative part of this Subsection.

G2 APPLICATION

This Annex shall apply to—

- a) vessels required by Subsection 6A to verify stability against comprehensive stability criteria; and
- b) vessels that might use KN data to show compliance with simplified criteria contained in Subsection 6A.

G3 OBJECTIVE

The objective of this Annex is to ensure that the stability characteristics calculated for a vessel at various angles of heel provide a highly reliable representation of the vessel's actual stability performance as it heels.

G4 KN DATA

G4.1 Reference datum for KN data

The reference datum for KN data from which the righting levers are measured shall be the intersection of the transverse centre line and the base line at the longitudinal measurement datum.

NOTE: The longitudinal measurement datum only becomes significant where KN data has been determined at a trimmed waterline.

G4.2 Free trimming method

KN data shall be calculated using the free trimming method whereby the vessel is free to trim by the bow or stern as it heels.

G4.3 Buoyant volume

The calculations used to derive the KN data may take into account the buoyancy contribution of spaces specified in Table G.1, subject to any conditions that are also specified.

Table G.1—Spaces considered buoyant for the calculation of KN data

Item	Details of application
Deck	Deck camber; and the upper surface of a timber or composite deck or deck sheathing material.
Planking	The outside surface of timber hull planking or timber hull sheathing.
Superstructures	For inclusion in the intact buoyancy space, the superstructure shall— a) be limited to only the first and second tiers above the freeboard or lowest weather deck; and b) comply with the strength and weathertightness requirements of NSCV Part C Section 2.
Deckhouses	For inclusion in the intact buoyancy space, the deckhouse shall— a) be limited to only the first tier above the freeboard or lowest weather deck; b) comply with the strength and weathertightness requirements of NSCV Part C Section 2; and c) have at least one exit provided to a deck above.
Trunks	For inclusion in the intact buoyancy space, the trunk shall— a) be on the freeboard or lowest weather deck or the first tier of a superstructure deck; and b) comply with the strength and weathertightness requirements of NSCV Part C Section 2.
Hatchways	For inclusion in the intact buoyancy space, the hatchway shall— a) be on the freeboard or lowest weather deck or the first tier of a superstructure deck; and b) comply with the strength and weathertightness requirements of NSCV Part C Section 2.

G4.4 Timber deck cargo

Supplemental KN data that takes into account the volume of the timber deck cargo may be determined for use when deriving the righting lever curve (G_{FZ} curve) in specific loading conditions on vessels that carry a timber deck cargo.

G4.5 Buoyant contribution of superstructures and deckhouses not regarded as enclosed

Where superstructures and deckhouses do not comply with the weathertightness requirements of NSCV Part C Subsection 2 then, subject to the method specified for deriving a righting lever curve (G_{FZ} curve) in accordance with Clause G5.2, the righting lever curve (G_{FZ} curve) may still be calculated taking into account a reduced buoyancy contribution provided by these spaces. The supplemental KN data calculated for such purposes shall comply with the remainder of the provisions in Table G.1.

G5 DERIVATION OF THE RIGHTING LEVER CURVE (G_{FZ} CURVE)**G5.1 Downflooding angle**

The righting lever curve (G_{FZ} curve) of a vessel shall be terminated at the point at which downflooding occurs. Downflooding shall be considered to have occurred at the angle where, due to flooding through openings—

- a) the vessel would sink; or
- b) the vessel's stability could be so significantly altered that it would no longer meet the intact stability criteria.

Table G.2 specifies the criteria to be applied when determining the point of downflooding.

Table G.2—Determination of downflooding

Item	Description
Openings that submerge at angles 30 degrees or less (1)	Openings that cannot be kept closed and which submerge at an angle of 30 degrees or less shall be considered as points of downflooding.
Openings that submerge at angles more than 30 degrees (1)	<p>For openings that submerge at angles of greater than 30 degrees, small openings that cannot be kept closed (such as those for passing wires or chains, drains and scuppers) need not be considered open for the purposes of determining the downflooding angle provided they satisfy the following criterion:</p> $\sum_1^S \left(\frac{A_S}{(0.62 \Delta + 0.9) \left[0.5 + 0.5 \left(\frac{\theta_{Sf} - 30^\circ}{10} \right) \right]} \right) \leq 1$ <p>where</p> <p>A_S = area of small opening S that is not considered a downflooding point which would terminate the righting lever curve (G_{FZ} curve), in square centimetres</p> <p>θ_{Sf} = angle to which the lowest sill of the small opening S immerses in the fully laden condition, but not to be taken as greater than 40; in degrees</p> <p>Δ = vessel displacement in the fully laden condition, in tonnes</p>
Deck openings within superstructures and deckhouses	<p>Deck openings within superstructures or deckhouses that comply with the strength and weathertightness requirements of NSCV Part C Section 2 shall be considered as closed even where no means of closure of the deck opening are provided.</p> <p>Deck openings having a means of closure that complies with the strength and weathertightness requirements of NSCV Part C Section 2 shall be considered to be closed notwithstanding that such a deck opening may lie within a deckhouse that does not comply with NSCV Part C Section 2.</p>

KEY:

(1) Tank vents and air ventilators that are provided with effective self-activating weathertight closing devices need not be considered openings for the determination of downflooding.

G5.2 Stability contribution of superstructures and deckhouses not considered enclosed

Subject to Clause G4.5, superstructures and deckhouses not regarded as enclosed may be taken into account in the calculation of G_FZ up to the angle at which their openings are flooded. At each such angle the righting lever curve (G_FZ curve) should show a step. For angles of heel above the point of flooding, the buoyancy contribution of the flooded space shall be considered non-existent.

ANNEX H ABBREVIATED STABILITY CALCULATION METHODS AND PRESENTATION

H1 SCOPE

This Annex specifies the requirements for abbreviated stability calculation methods for use by vessel *operators* that lack the competencies to fully calculate a loading condition and verify its compliance against the relevant stability criteria.

This Annex is a normative part of this Subsection.

H2 APPLICATION

This Annex applies to vessels that are required by Clause 5.4.6.2 to be provided with abbreviated stability calculation methods for use by the *operator*.

H3 OBJECTIVE

The objective of this Annex is to enhance vessel safety by providing the *operator* with a less complex and readily useable means to determine whether the stability of a vessel complies with minimum criteria without the *operator* having to derive and analyse a righting lever curve (G_Z curve).

H4 PREPARATION OF ABBREVIATED STABILITY DATA

H4.1 Approach

The abbreviated stability calculation method shall specify compliance in terms of one or more key stability parameters that can be applied to define the state of the vessel. Abbreviated stability data shall be provided that specifies compliance in terms of limits to the relevant key stability parameters.

H4.2 Key stability parameters

The key stability parameters shall be chosen to best describe the variables that determine the vessel's stability in different conditions of loading, taking into account the type of vessel, its operation and the means for the *operator* to determine the magnitude of the variables. The abbreviated stability data shall be derived using one of the key stability parameters specified in Table H.1.

NOTE: An abbreviated stability calculation method that applies key stability parameters other than those specified would be considered as a proposal for an equivalent solution.

Table H.1— Key stability parameters for generating abbreviated stability data

Key stability parameters	Typical application
Limiting deadweight mass moment at various drafts or displacements	Vessels that carry deck or other cargoes
Limiting <i>KG</i> above the baseline at various drafts or displacements	Crane barges, fishing vessels, cargo vessels
Limiting height of the centre of gravity of deck cargo above the cargo deck	Landing craft, crane barges, barges that carry deck cargo

H4.3 Determination of abbreviated stability data

The relationship between variations in the key stability parameters and the vessel's compliance with the relevant stability criteria shall be investigated by a series of loading condition calculations that establish the limits of compliance over the range of operating drafts or displacements. The abbreviated stability data shall be presented in graphical or tabular form for *level trim* and for other trims covering the full operational trim range of the vessel. The abbreviated stability data shall clearly specify the values and/or (for graphical representations) the zones of the key stability parameters that constitute—

- a) acceptable operation; and
- b) operation that is dangerous and therefore unacceptable.

H4.4 Assumptions to be specified

The simplified stability data shall specify the assumptions of loading, heeling moments, allowable angles of heel, downflooding, tank usage, free surface and trim that were used in the determination of the limits to compliance.

H5 PRESENTATION OF THE ABBREVIATED STABILITY CALCULATION METHOD

Abbreviated stability calculation methods may either be incorporated within the stability book specified in Annex F modified in accordance with Table H.2 or they may be incorporated in an *operator's* stability manual with the function of stability compliance report being fulfilled by a separate document, see Table H.2.

NOTE: The latter approach has the advantage that extraneous information that might confuse the user is omitted.

Table H.2—Presentation of abbreviated stability calculation methods

Item	Stability book incorporating abbreviated stability calculation methods	Separate <i>operator's</i> stability manual (OSM) and stability compliance report (SCR)	Comments
Title page	Stability book title, name of vessel, classes of service and the date of preparation or latest amendment shown.	(OSM & SCR) Title, name of vessel, classes of service and the date of preparation or latest amendment shown	
Contents page	Contents referenced by page numbers	(OSM & SCR) Contents referenced by page numbers	All pages to be consecutively numbered
Particulars of the vessel and measurement datums	<ul style="list-style-type: none"> - General particulars - Drawing of vessel - Draft mark diagram - Load line diagram 	(OSM & SCR) <ul style="list-style-type: none"> - General particulars - Drawing of vessel - Draft mark diagram - Load line diagram 	See Clause F6
Applicable stability criteria	Refer to NSCV Part C Subsection 6A	(OSM & SCR) Applicable stability criteria; refer to NSCV Part C Subsection 6A	Specify the allowable angle(s) of heel for single/combined heeling moments as applicable
Immersion angle information	Angles of deck edge immersion, downflooding and potential downflooding;	(SCR) Angles of deck edge immersion, downflooding and potential downflooding	See Clause F7
Guidance for the <i>operator</i>	<ul style="list-style-type: none"> - Purpose - Limiting conditions - Warnings - Explanations to the stability book - Operation of the vessel 	(OSM) <ul style="list-style-type: none"> - Purpose - Limiting conditions - Warnings - Explanations to OSM - Operation of the vessel 	See Clause F8
Heeling moments	Data to allow calculation of heeling moments including person, wind, turning and those from special operations. Refer to NSCV Part C Subsection 6A	(SCR) Data to allow calculation of heeling moments including person, wind, turning and those from special operations.	To either take into account changes in heeling moment that occur as displacement varies or a value representing the maximum heeling lever that can arise at any displacement.
Loading conditions	Lightship conditions, worst case loading conditions, loading conditions for special operations	(OSM) Show loading tables only (SCR) As per stability book	See Clause F9
Simplified stability data	In graphical or tabular format with assumptions and the limits of acceptable operation and dangerous operation clearly specified.	(OSM) In graphical or tabular format with assumptions and the limits of acceptable operation and dangerous operation clearly specified.	See Clause H4
Worked example of loading condition	Instructions on how to apply the abbreviated stability calculation method.	(OSM) Instructions on how to apply the abbreviated stability calculation method.	

(Continued)

Table H.2 (Continued)

Item	Stability book incorporating abbreviated stability calculation methods	Separate operator's stability manual (OSM) and stability compliance report (SCR)	Comments
Tank information	<ul style="list-style-type: none"> - Tank layout diagram - Tank summary table - Tank calibration data 	(OSM & SCR) <ul style="list-style-type: none"> - Tank layout diagram - Tank summary table - Tank calibration data 	See Clause F10 Tank calibrations not required for tanks kept full in service.
Cargo and stores information	<ul style="list-style-type: none"> - Dry cargo space and store space diagram - Dry cargo and store space summary table - Cargo space calibration data - Deadweight scales 	(OSM & SCR) <ul style="list-style-type: none"> - Dry cargo space and store space diagram - Dry cargo and store space summary table - Cargo space calibration data - Deadweight scales 	See Clause F11 The requirement for deadweight scales is limited to Class 1 or Class 2 vessels over 24 m in length that load cargoes.
Hydrostatic and <i>KN</i> data	<ul style="list-style-type: none"> - Hydrostatic data - <i>KN</i> data 	(SCR) <ul style="list-style-type: none"> - Hydrostatic data - <i>KN</i> data 	See Clause F12
Lightship particulars	Report of the inclining experiment or lightship measurement including the calculations used to determine the lightship condition characteristics	(SCR) Report of the inclining experiment or lightship measurement including the calculations used to determine the lightship condition characteristics	See Clause A8.8

ANNEX J GUIDANCE FOR PREPARATION OF A STABILITY NOTICE

J1 SCOPE

This Annex provides guidance on the preparation of a stability notice for display in the operating compartment of a vessel.

This Annex is an informative part of this Subsection.

J2 APPLICATION

This Annex applies to vessels that are permitted to carry simplified stability documentation under Clause 5.4.6.3c).

J3 GENERAL

The stability notice should be concise and preferably limited to a single A4 page, or at most two such pages. The stability notice should specify the following:

- a) The name and identifying number of the vessel.
- b) Class or classes of service.
- c) The type of criteria applied to the vessel (refer to Subsection 6A for applicable criteria).
- d) Statement of obligation of the *operator* to avoid extremes of weather and waves and to keep vessel upright.
- e) Reference to the *operator's* stability manual, see Clause 5.4.6.3 b).
- f) General limitations on the vessel arising from compliance with the criteria including:
 - i) Service categories.
 - ii) Nature, number and distribution of persons on board.
 - iii) Nature, number and distribution of passengers on board.
 - iv) Maximum allowable draft and/or freeboard.
 - v) Limitations on the carriage of fuel, water, stores and other weights such as fishing gear.
- g) General limitations arising from special operations such as carriage of sail, towing of vessels, lifting of weights, etc.
- h) Special limitations that might arise such as the use of transparent plastic windows (clears), awnings and screens.

J4 GRAPHICAL TOOLS

The stability notice should incorporate such graphical tools that might be available to assist the *operator* to maintain the vessel within acceptable stability limits.

EXAMPLE:

For a vessel that sets sails, a graphical presentation of maximum steady angle to prevent downflooding in gusts.

ANNEX K SPECIFICATION FOR THE FORMAT, POSITIONING AND MARKING OF DRAFT MARKS

K1 SCOPE

This Annex specifies the requirements for the marking of draft marks on vessels.

This Annex is a normative part of this Subsection.

K2 APPLICATION

This Annex shall apply to the vessels specified in Clause 6.4 and other vessels that carry draft marks at the owner's option.

K3 OBJECTIVE

The objective of this Annex is to ensure the following:

- a) The measurement datums used for specifying draft marks are directly applicable to physical characteristics of the vessel so as to facilitate the avoidance of hazards such as grounding or standing.
- b) The draft marks, where provided, are accurately positioned relative to their measurement datums.
- c) The draft marks are marked in such a way as to minimise the likelihood of human error occurring when draft marks are being read, and in their subsequent use for calculations and when determining potential hazards.

REQUIRED OUTCOMES

K4 READY AND ACCURATE READING OF DRAFTS

Means must be provided that enable the ready and accurate reading of drafts over the range of operating displacements, taking into account potential variations in trim and any likely operational constraints that may limit the capacity of personnel to read drafts at time of need.

DEEMED-TO-SATISFY SOLUTIONS

K5 COMPLIANCE

For the purpose of this National Standard, the provision of the required draft marks shall be deemed to satisfy the required outcome in Clause K4 if the vessel is provided with draft marks that comply with Clauses K6 to Clause K10.

NOTE: Where a vessel is such that draft marks cannot be located in a position where they can be easily read, or where operational constraints make it difficult to read the draft marks, then an alternative draft indicating system could be considered as a proposal for an equivalent solution.

K6 LOCATION OF DRAFT MARKS**K6.1 Forward, amidships and aft locations**

Draft marks shall be provided at both the forward and aft ends of the vessel. Vessels of measured length 40 m or more shall also be provided with draft marks amidships.

K6.2 Port and starboard locations

Except as specified in the following, the forward, aft and, where applicable, amidships draft marks shall be marked on both sides of the vessel. For vessels of measured length less than 24m, separate sets of port and starboard forward or aft draft marks may be replaced by a single set of draft marks on the centre line of a transom, snub bow or other suitable structure.

NOTE: Widely separated draft marks port and starboard can be used to monitor the extent of list or heel of a vessel.

K6.3 Positioning of draft marks

Forward and aft draft marks shall be positioned as far forward and aft as practicable consistent with ensuring that they can be safely and accurately read. Amidships draft marks shall be positioned as close to amidships as practicable. Draft marks that are intended to be marked vertically one above the other shall be located along a line that is perpendicular to the designed waterline.

K6.4 Suitable surfaces for draft marks

Draft marks shall be marked on structures that are permanent and integral with the hull. Draft marks shall not be marked on moveable structures such as rudders or azimuthing thruster nozzles unless the configuration of the vessel is such that there is no practical alternative, see Figure K.5.

Where draft marks would be marked on surfaces of the hull that are less than 40 degrees from the horizontal plane, the draft marks shall wherever practicable be duplicated or substituted by a second set of draft marks marked on hull surfaces that form an angle of 40 degrees or more with the horizontal plane, see Figure K.5 and Figure K.6.

NOTE: Typical arrangements for the longitudinal positioning of draft marks are illustrated in Figure K.4 and Figure K.5.

K7 DRAFT MARK VERTICAL DATUM

Draft markings on a vessel shall be marked relative to the applicable draft mark vertical datum specified in Table K.1. The locations of the draft datums for a variety of hull configurations are illustrated in Figure K.1 to Figure K.5.

Table K.1—Draft mark vertical datum

Keel configuration of vessel	Aft draft marks	Midship draft marks	Forward draft marks
Without rise of keel, see Figure K.1a)	Underside of keel (USK)	Underside of keel (USK)	Underside of keel (USK)
With forward rise of keel, see Figure K.1b)	Line parallel to the designed load waterline passing through the lowest point of the vessel (1)	Line parallel to the designed load waterline passing through the underside of keel at amidships	Line parallel to the designed load waterline passing through the tangent point forward
With aft rise of keel, see Figure K.1c)	Line parallel to the designed load waterline passing through the tangent point aft	Line parallel to the designed load waterline passing through the underside of keel at amidships	Line parallel to the designed load waterline passing through the lowest point of the vessel (1)
With rocker in keel, see Figure K.1d) or fin keel, see Figure K.1a)	Line parallel to the designed load waterline passing through the lowest point of the vessel (1)	Line parallel to the designed load waterline passing through the lowest point of the vessel (1)	Line parallel to the designed load waterline passing through the lowest point of the vessel (1)

KEY:

(1) Lowest point of the vessel may be located on the keel, skeg, rudder, propeller, sensor housing.

K8 RANGE OF DRAFT MARKS TO BE MARKED

The draft marks shall extend from a waterline below the lightship waterline to a waterline above the fully laden waterline of the vessel, taking into account potential variations in trim over the range of loading conditions. As a minimum deemed-to-satisfy solution, the range of draft marks shall be not less than that specified in Table K.2, see also Figure K.4 and Figure K.5.

Table K.2—Minimum range for draft marks

Location	Measurement datum	Minimum vertical distance (mm)
Above the fully laden design waterline	To upper edge of uppermost numeral	$20 \times L_M$
Below the lightship waterline	To the lower edge of the lowermost numeral	$20 \times L_M$

KEY:

 L_M is the measured length of the vessel, in metres

K9 MARKING OF DRAFTS

Each set of draft marks shall comply with the following (see also Figure K.6):

- a) The drafts marks shall be in Arabic numerals that denote the vertical distance above the relevant draft datum.
- b) The draft marks shall be permanently marked on the vessel so that they can be reinstated after painting without having to be remeasured.

NOTE: Such permanent marking might include welding, cutting in, encapsulation or affixing by nails.

- c) The draft marks shall be positioned such that the lowest edge of each numeral is located at the specified draft.
- d) Draft mark numerals shall be provided at every 200 mm interval of draft.
- e) Draft mark numerals shall be sized such that their vertical projection is 100 mm high.

NOTE: For example, in the case where the hull surface is angled at 30 degrees to the vertical, there will be an error of 13 mm in the height of the 100 mm numeral.

- f) Draft marks corresponding to one metre intervals shall have the letter 'M' added immediately following the numeral.
- g) The uppermost draft mark shall have the letter 'M' included.

K10 RECORDING OF DRAFT MARK INFORMATION

Details of the essential longitudinal and vertical dimensions and datums used to establish the location of draft marks on a vessel shall be recorded for reference when applying or reinstating the draft information.

NOTES:

1. The longitudinal position of draft marks is used to calculate trim between perpendiculars, draft at the centre of flotation and displacement.
2. Such information is normally recorded in a diagram included in the stability book, or simplified stability information.
3. The National Regulator may require that the location of draft marks be independently verified as part of a vessel survey process.

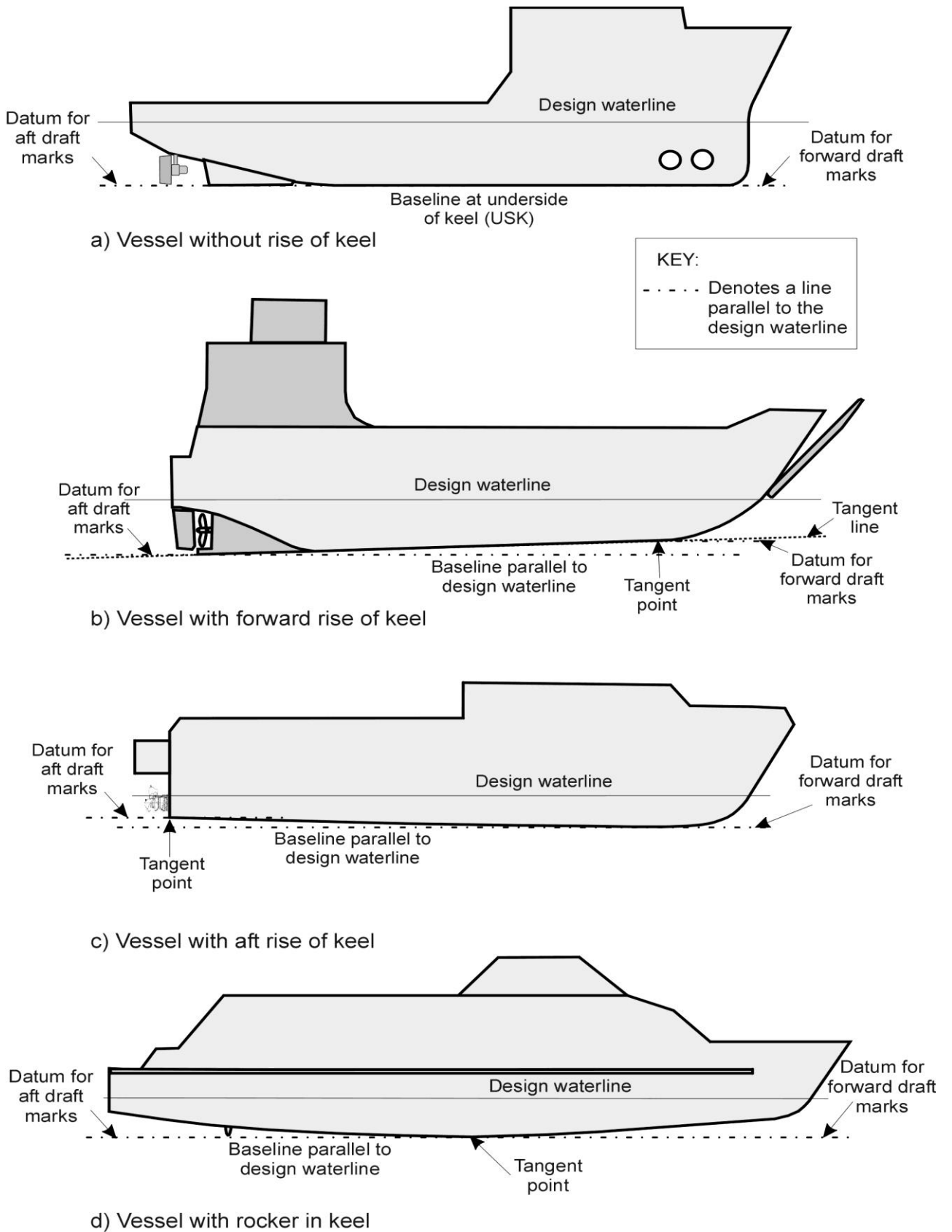

Figure K.1—Baseline and draft datums for typical keel configurations

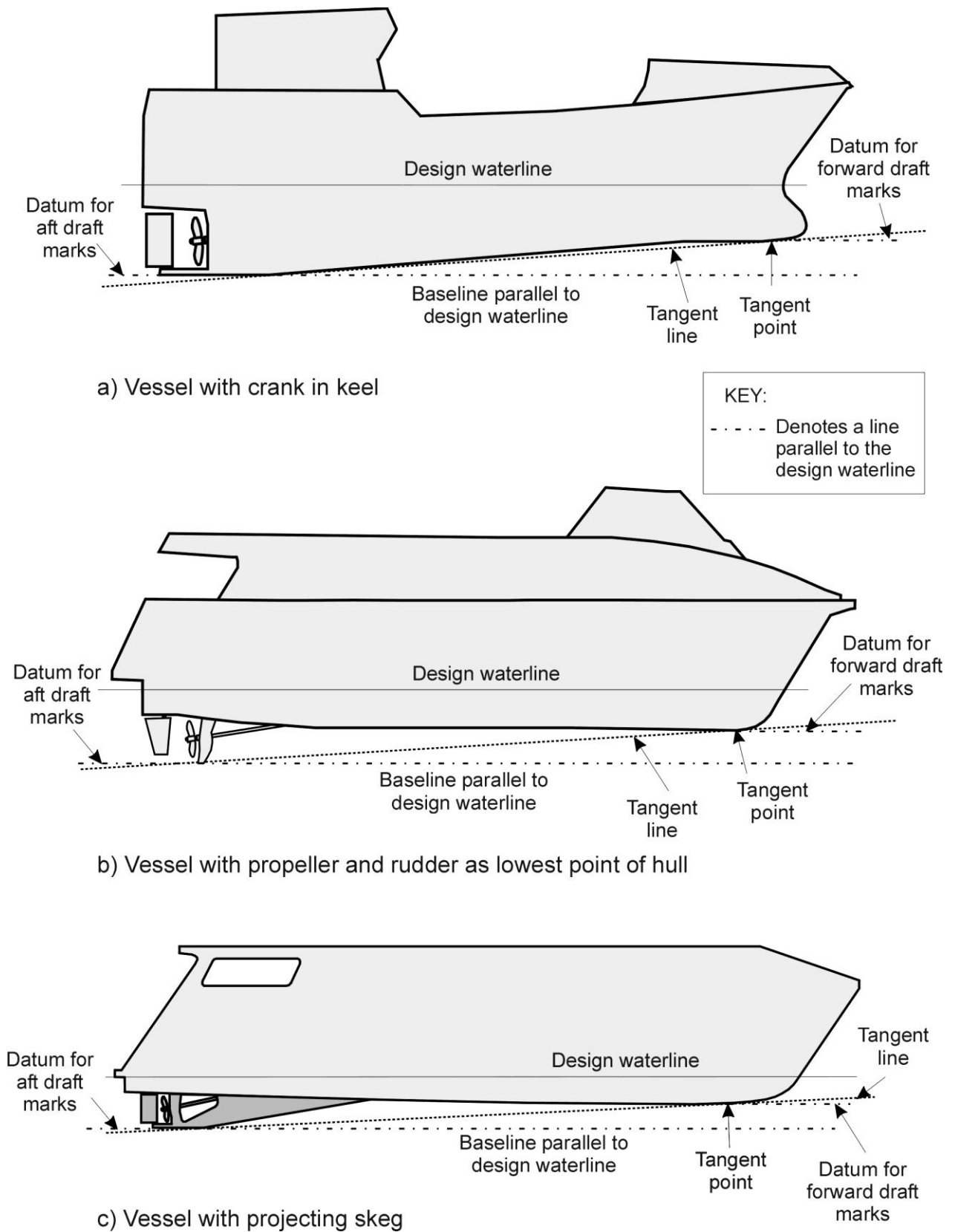

Figure K.2—Baseline and draft datums for keel variations

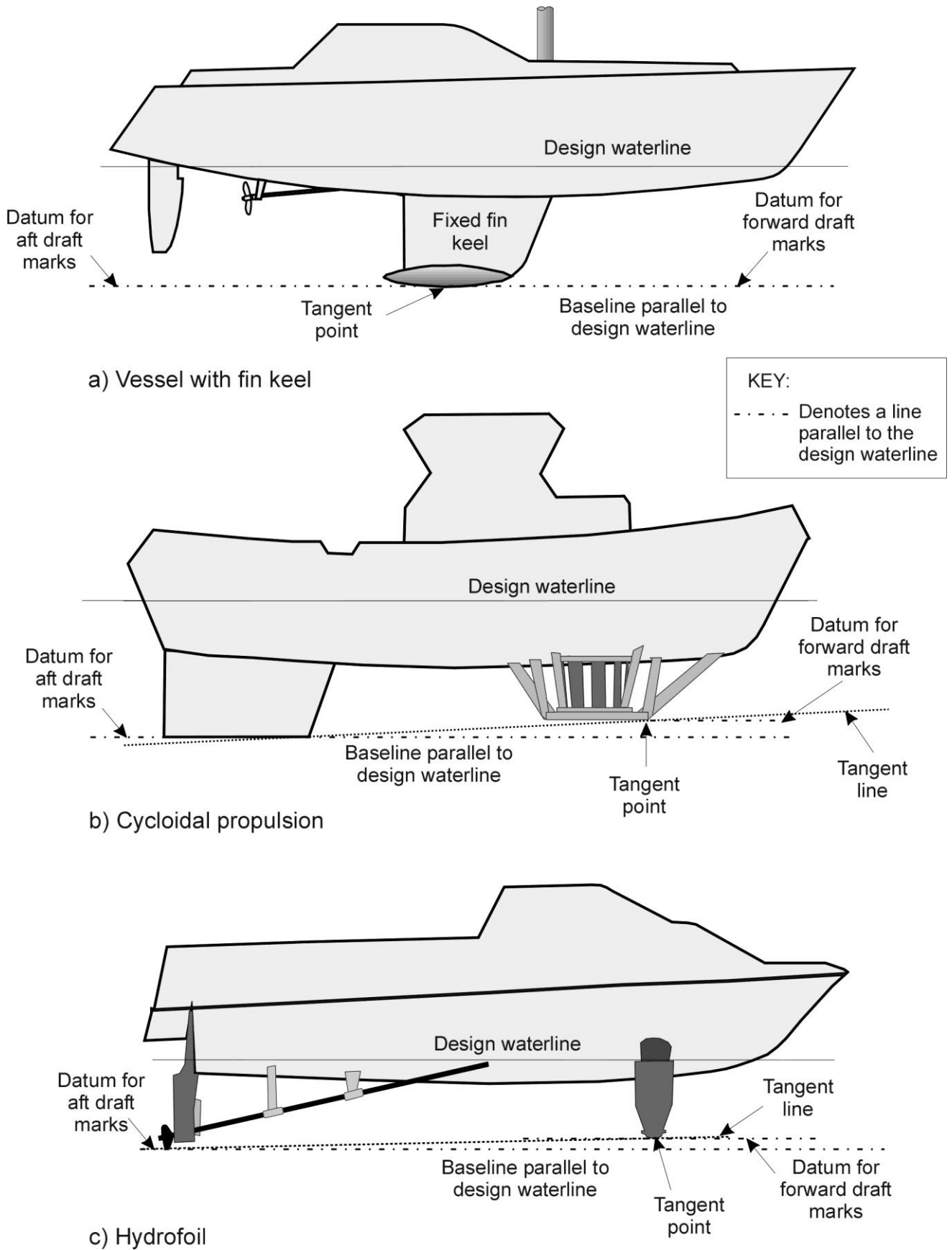

Figure K.3—Baseline and draft datums for particular vessel types

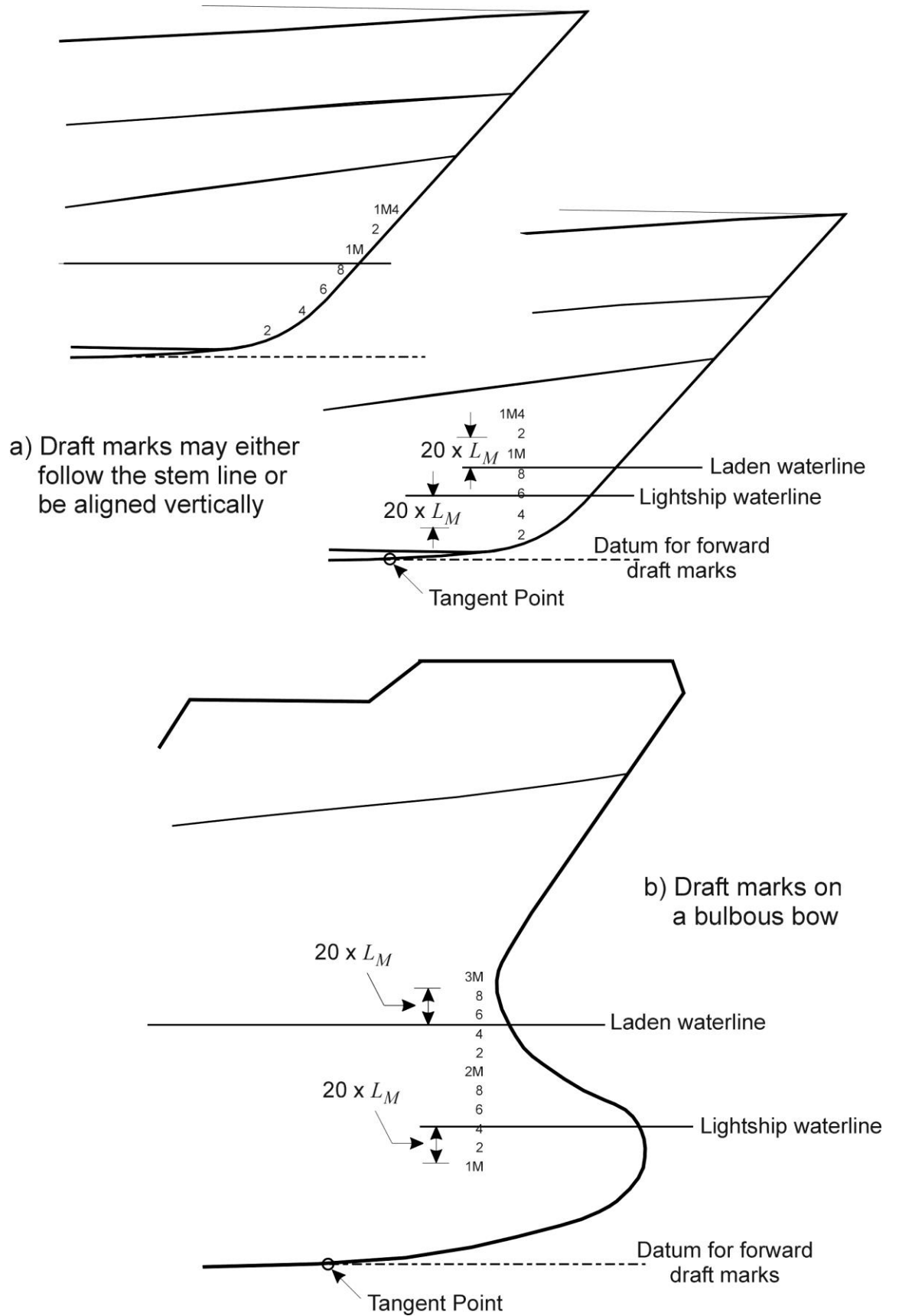

Figure K.4—Forward draft marks

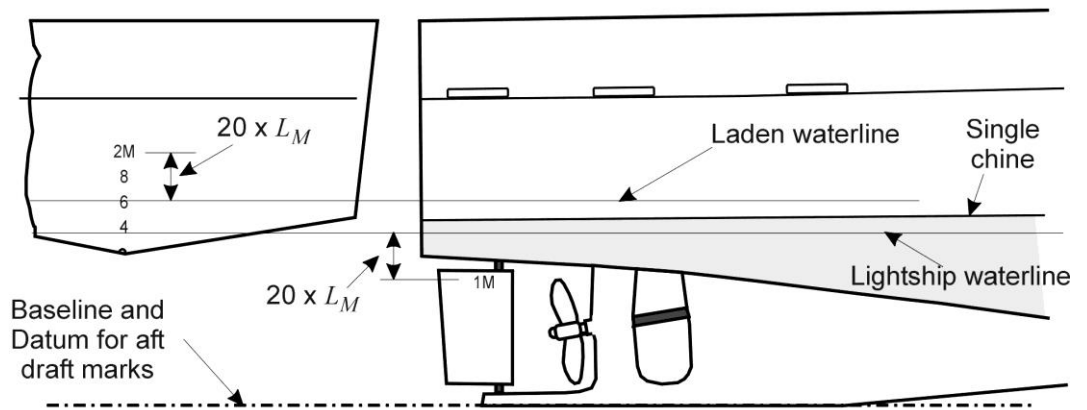
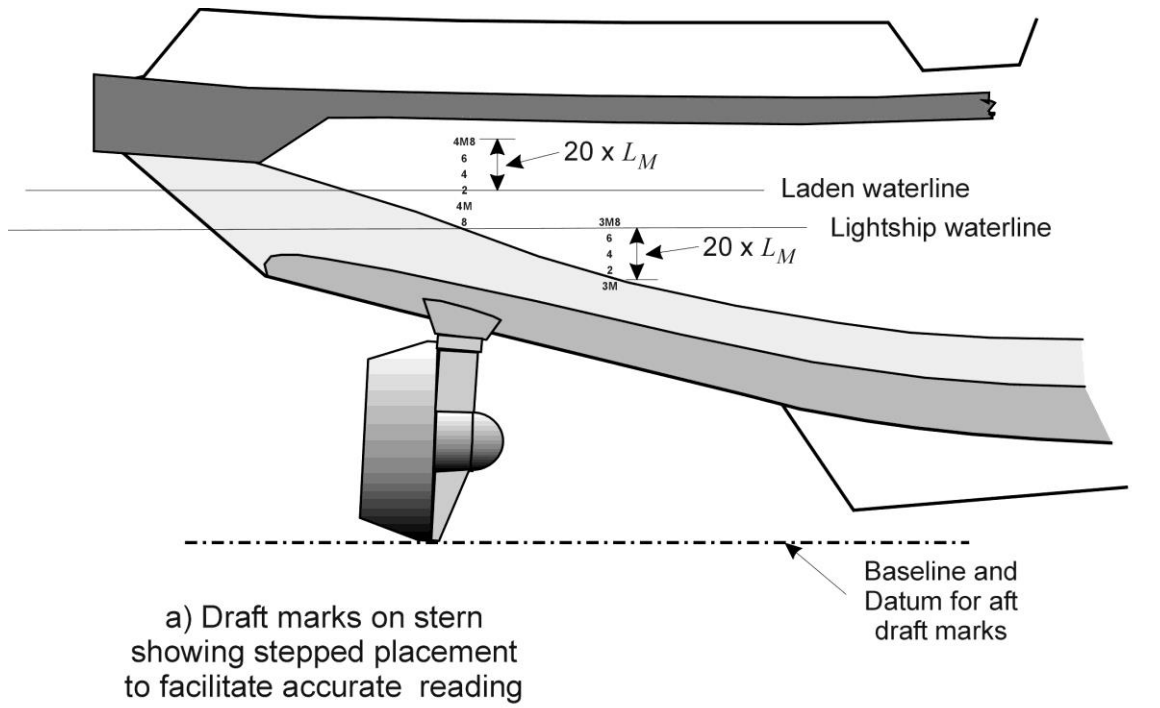

Figure K.5—Aft draft marks

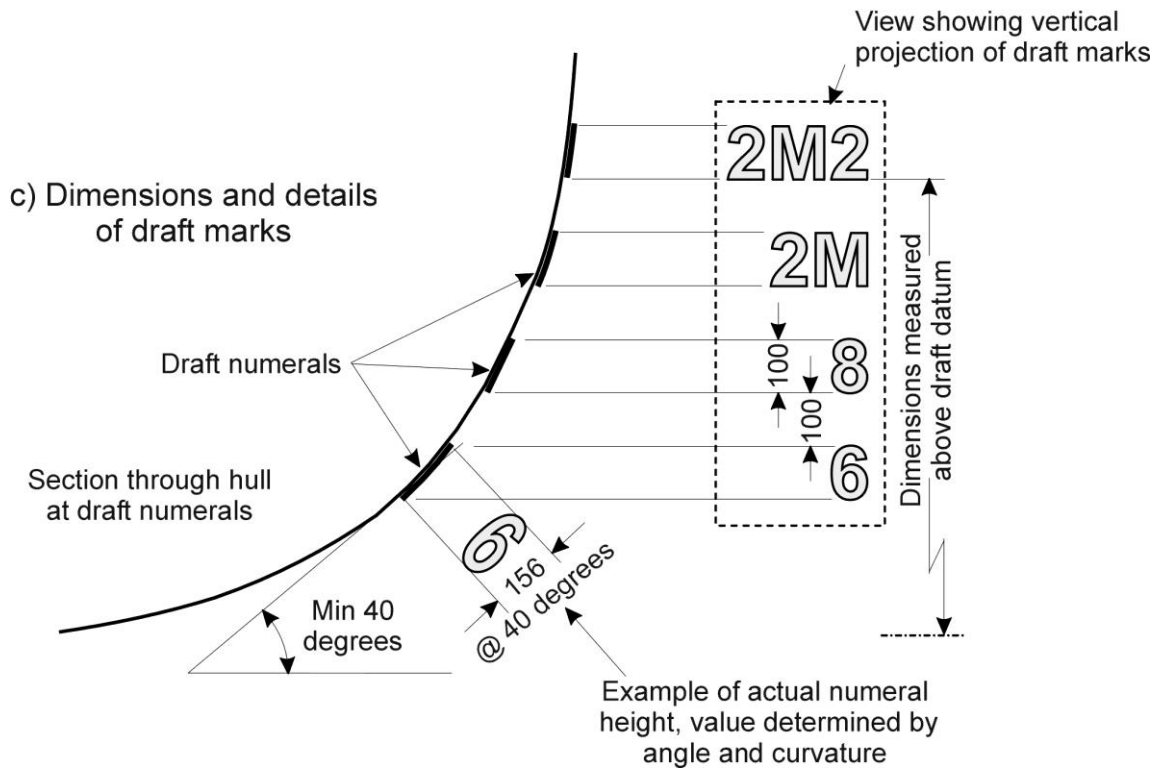
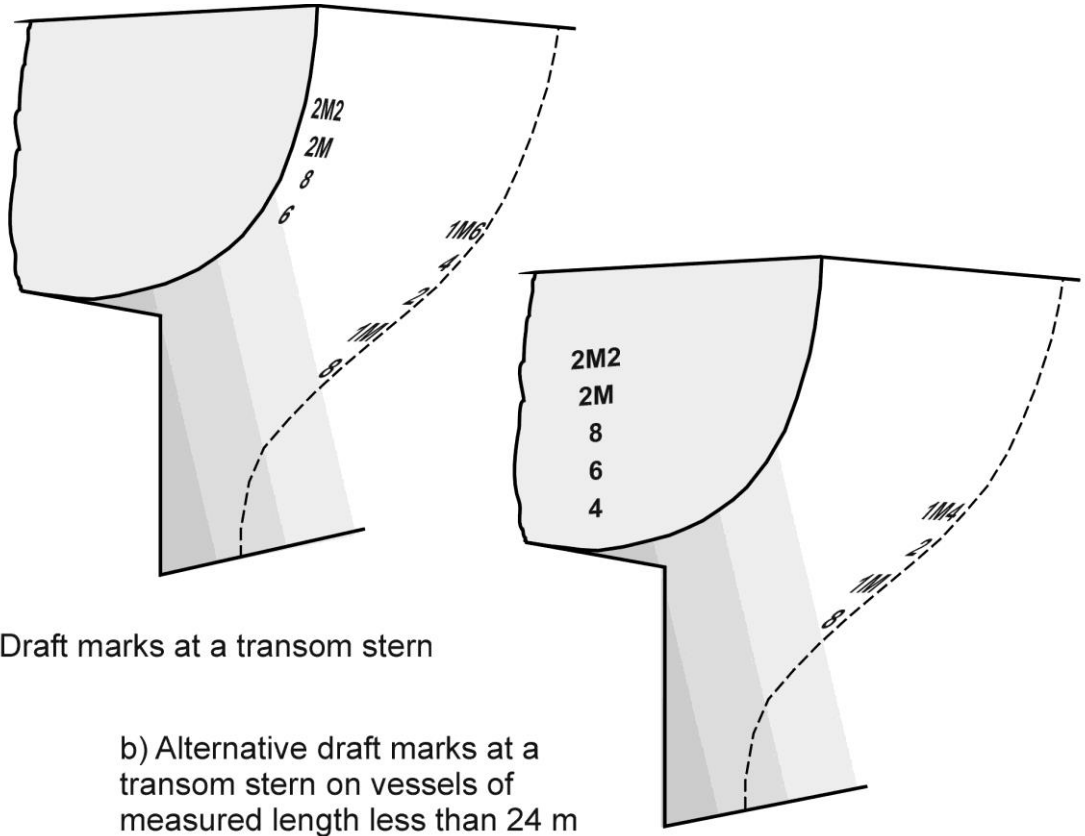

Figure K.6—Draft mark details and dimensions

ANNEX L METHOD FOR DETERMINING FREEBOARD

L1 SCOPE

This Annex specifies the requirements and method to be employed in determining or calculating freeboard on a vessel enclosed by a weathertight deck that has discontinuous sheer.

The Annex is a normative part of this Subsection.

L2 APPLICATION

This Annex applies to vessels that are subject to a practical inclining experiment or stability proof test as specified in Clause 4.4.

The Annex is referenced in Clauses E7.12 and E7.13. It is also relevant to Annex D to that extent that it may be applied to determine the magnitude of the Chapter 7A criteria specified in Subsection 6A.

L3 OBJECTIVE

The objective of this Annex is to provide a uniform method for determining freeboard.

L4 LONGITUDINAL LOCATION OF FREEBOARD MEASUREMENT

The freeboard shall be measured at the point of least freeboard or at a point $0.75 L_M$ from the bow if the point of least freeboard is aft of $0.75 L_M$ from the bow (L_M is the measured length of the vessel).

L5 VERTICAL DATUM FOR FREEBOARD MEASUREMENT

The freeboard shall be measured from the waterline (WL) to a point as specified in Table L.1 that is dependent upon the vessel's configuration.

Table L.1—Vertical datum for freeboard measurements

Configuration	Freeboard to be measured from the waterline (WL) to...
Decked vessel	The top of the weather deck at side (1)
Well deck vessel	The top of the weather deck at side (1)
Cockpit vessel	The top of the gunwale
Open vessel	The top of the gunwale

KEY:

(1) For vessels with a discontinuous sheer, the line of the geometric freeboard at side is determined in accordance with Clause L6.

L6 DETERMINATION OF FREEBOARD FOR VESSELS WITH DISCONTINUOUS SHEER

For vessels with a discontinuous sheer, instead of taking the freeboard to the lowest part of the deck, a geometric freeboard may be determined by calculation of a mean freeboard based on the freeboard measured to each of the intact decks within the vessel over the length on the waterline (L_{WL}).

Where a vessel has a forepeak bulkhead or superstructure to partially or fully enclose the cockpit well deck weathertight, the freeboard of this particular section shall be taken to the gunwale average freeboard for the purpose of calculating the geometric freeboard.

NOTE: The allowance for discontinuous sheer assumes that spaces below decks remain effectively buoyant during transient immersion of the weather deck; i.e., such spaces satisfy the watertight and weathertight integrity requirements of NSCV Section 2.

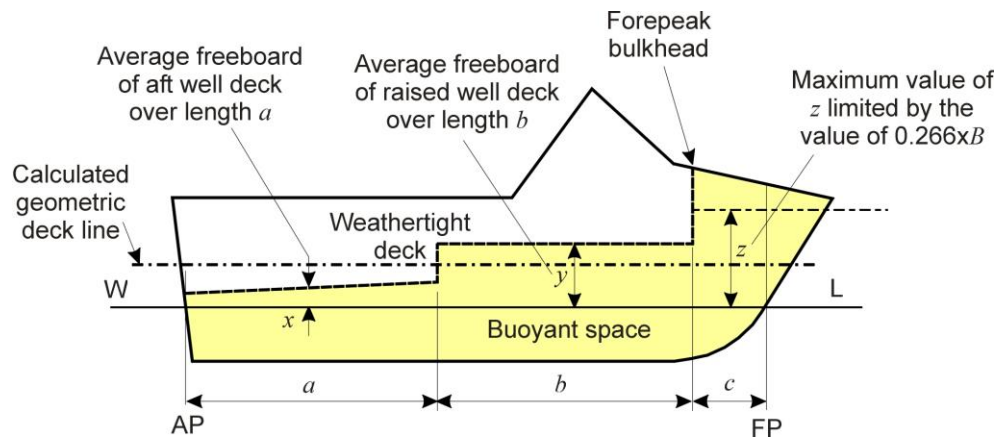

Figure L.1—Geometric freeboard

The geometric freeboard shall be calculated as follows (see Figure L.1):

$$FBD_{Geo} = \frac{ax + by + cz \dots}{a + b + c \dots}$$

where

FBD_{Geo} = the geometric freeboard

a, b, c, \dots = the length of each applicable intact deck

x, y, z, \dots = the lesser value, in metres of—

a) the mean height of each deck above the design waterline; and

b) $0.266 B$

where B is the breadth of the vessel; in m

ANNEX M INFORMATION ON BUOYANCY AND STABILITY AFTER FLOODING

M1 SCOPE

This Annex specifies the minimum deemed-to-satisfy requirements for the form and content of information on buoyancy and stability after flooding. It forms a normative part of this Subsection.

M2 APPLICATION

The provisions of this Annex shall apply to all vessels required by Chapter 5 to have stability documentation.

M3 INFORMATION TO BE INCLUDED IN THE STABILITY DOCUMENTATION OR OPERATING MANUAL

M3.1 Information to be aimed at competence of user

The Information relevant to buoyancy and stability after flooding provided to the *operator* shall be kept concise and in a form readily understood by persons having competencies corresponding to the minimum levels prescribed by Marine Order 505.

NOTE: Where a vessel has features that require competencies beyond that provided by compliance with the minimum standards, these shall be highlighted with a requirement that appropriate training be provided.

M3.2 Removal of water from spaces within the vessel

The operator shall be provided with information that identifies—

- a) the spaces in which water can collect;
- b) the means by which the presence and quantity of water is to be ascertained; and
- c) the means by which water which has leaked into the space is to be removed.

M3.3 Standard of buoyancy and stability after flooding

The operator shall be provided with a description in general terms of the standard of buoyancy and stability after flooding that applies to the vessel (refer to NSCV Part C Subsection 6B), together with a commentary on the limitations of the safety outcomes that arise from such a standard. The damage stability information shall provide the operator with a simple and easily understandable way of—

- a) Identifying the worst-case loading conditions with respect to flooding;
- b) assessing whether the vessel's actual loading condition is no more severe with regard to reserve buoyancy, stability and trim than those used for assessment of the vessel's buoyancy and stability after flooding, and
- c) assessing the vessel's survivability in all flooding cases involving a compartment or group of compartments.

NOTE: Limiting KG_f and damaged stability computers can be of assistance for providing ready information.

M3.4 Loading conditions critical to buoyancy and stability after flooding

The operator shall be provided with information that—

- a) specifies which, if any, of the loading conditions presented for intact stability in this Subsection represent limiting conditions for compliance with the criteria for buoyancy and stability after flooding; and
- b) indicates whether compliance with the criteria for buoyancy and stability after flooding is the limiting condition for assignment of the load line in Part C Section 2.

M3.5 Location, operational status and emergency operation of essential components and machinery

The operator shall be provided with information on the location and use of weathertight and watertight closing appliances, watertight bulkheads, watertight doors, foam buoyancy, air chambers and, where applicable, any cross-flooding fittings, etc. The information shall specify the normal operational status and the operation in emergency circumstances. Any watertight doors permitted to remain open during navigation shall be clearly indicated.

NOTE: Part of this information may be incorporated into the Damage Control Plan specified in Clause M4.

M3.6 Vessels with inflated collars

For vessels with inflated collars, the operator shall be provided with procedures describing—

- a) the method of inflation of collars;
- b) the required working inflation pressure and the means for measuring pressure;
- c) ongoing care and maintenance of the inflated collar;
- d) actions to be taken in the event of chambers losing pressure; and
- e) the repair procedure for collars.

M4 DAMAGE CONTROL PLAN

For vessels of measured length 24 m or more, or vessels of Flooding Risk Category III or IV (refer to NSCV Part C Subsection 6B), a damage control plan shall be permanently exhibited in the main operating compartment showing clearly for each deck and hold the boundaries of the watertight

compartments, the openings in those compartments, the means of closure and where relevant the arrangements for the correction of any list due to flooding¹.

NOTE: For vessels of measured length less than 35 m, the separate Damage Control Plan under this Clause and the Fire Control Plan specified in Part C Section 4 may be combined into a single Emergency Plan.

M5 COMPLIANCE REPORT

The vessel's compliance with the requirements of NSCV Part C Subsection 6B shall be documented in a compliance report for reference by Marine Authorities and other stakeholders responsible for the safety of the vessel.

NOTE: Detailed calculations or computer program output showing compliance with the criteria contained within this Subsection should not normally be included in documentation intended for use by the operators of the vessel as they would not normally have the competencies required to interpret and apply the information.

¹ Refer to the IMO Guidelines for damage control plans (MSC/Circ.919)